

Section B

BITUMEN - ASPHALT

section B



The use of bituminous materials is mainly addressed to roads construction.

The asphalt, named also bitumen, is mainly composed by aggregates and binder, with an infinite variation of mixtures.

It is therefore necessary to get suitable equipment to perform different test methods and to determine: binder content, internal friction, cohesion, consistency, softening point, viscosity, quality of aggregates, voids percentage, levels of compaction, stiffness modulus, fatigue resistance, Marshall test, and many other parameters.

The equipments described in this Section largely satisfy all these test procedures, conform to the new EN Standards on road materials tests, and replace those previous national Standards.



B005

Bitumen content furnace by ignition method

STANDARDS: EN 12697-39 / ASTM D6307 / AASHTO TP53 / NCAT (National Centre for Asphalt Technology) / BS (DD)

section B



70



B005

detected; the unit begins to beep but will continue to test until the user presses "stop" to end it. Once the "stop" button has been pressed, the door will unlock and the results will be printed.

Furnace software automatically compensates for weight change due to sample and basket assembly temperature change. This compensation is computed for each sample load tested, unlike competitive models that assign a fixed number to a given range of load sizes.

The Furnace is supplied complete with 4 baskets, 2 trays, 2 covers, handle, cooling cage, insulated plate, gloves, face shield, 4 rolls of printer tape.

Overall dimensions: 552x654x933 mm
Chamber Dimensions: 355x355x355 mm

Power supply:
230V 1 F 50 Hz 4800 W 20 A
Temperature range: 200-650°C
Weight: 120 kg

ACCESSORY:

B005-10

Metal stand to hold the furnace.

The unit provides asphalt content of bituminous paving mixtures accurate to 0.11%, with a fast, accurate, environmentally friendly, and cost effective method of determining asphalt content.

Ignition method reduces testing time when compared to solvent extraction. A 1200-1800 gram sample of asphalt can be tested in 30-45 minutes using this Content Furnace.

Unit can accommodate samples up to 5000 grams!

MATEST Furnace has an internal scale, that automatically monitors the sample weight throughout the ignition process, saving valuable technician time and increasing productivity in the lab.

The ignition method replaces the costly and time consuming solvent extraction method by eliminating the primary cost of solvent purchase and the secondary cost of solvent disposal.

MATEST Content Furnace eliminates the exposure of the asphalt technician to harmful solvents. The automatic door-lock feature prevents opening the chamber door during the critical test time.

This feature provides operator safety and helps ensure testing integrity. This Content Furnace is the only system on the market containing a high temperature afterburner used in conjunction with a patented ceramic filter to reduce the emissions of the ignition process by up to 95%. Our System has the capability to accept positive or negative correction factors for use with mixes containing hydrated lime. This unique furnace automatically detects endpoint within .01% of the sample weight. Furnace software allows you to choose between automatic and manual test mode. In the automatic mode, the endpoint is detected; the software ends the test, prints out the results and beeps. In the manual mode, the endpoint is

detected; the unit begins to beep but will continue to test until the user presses "stop" to end it. Once the "stop" button has been pressed, the door will unlock and the results will be printed. Furnace software automatically compensates for weight change due to sample and basket assembly temperature change. This compensation is computed for each sample load tested, unlike competitive models that assign a fixed number to a given range of load sizes. The Furnace is supplied complete with 4 baskets, 2 trays, 2 covers, handle, cooling cage, insulated plate, gloves, face shield, 4 rolls of printer tape. Overall dimensions: 552x654x933 mm Chamber Dimensions: 355x355x355 mm Power supply: 230V 1 F 50 Hz 4800 W 20 A Temperature range: 200-650°C Weight: 120 kg



B005 - accessories

A022N

Muffle furnace 1100°C.

STANDARD: EN 12697-1 clause C, EN 13108

This furnace is used for the determination of residual mineral matter by incineration of the bituminous mixtures.

Technical details: see Section "A"

Aggregates, pag. 28



ACCESSORY:

VI14-10

SILICA evaporating dish, dia. 130x23 mm (160 ml capacity)

A022N

B008

Automatic binder extraction unit

STANDARDS: EN 12697-1, EN 13108
 CNR a.VII N °38
 DIN 1996 / ASTM D2172

Used to perform reliable analysis on bituminous mixtures utilizing the perchloroethylene (PCE) or tetrachloroethylene solvent which is classified: R40 not cancer producing (see note*), for quantitative determination of binder or bitumen contained in pavement samples and hot mixed mixtures.

The system performs in only one complete automatic cycle:

- the washing, disaggregation and separation of the bituminous mixture;
- the separation of the filler from the solution formed by solvent, bitumen and filler;
- the recovery and distillation of solvent material allowing a further utilization.

This unit, in a short time, performs out a serie of analysis that normally require a long time and labour, by reducing extraction costs.

The unit comprises:

- An electromagnetic sieving unit, insuring high quality double vibrating action (vertical/rotational), with solvent spraying cover for washing and disaggregation of the sample.
- A continuous flow filterless centrifuge having rotation speed of 11000 rpm equipped with a stainless steel beaker dia. 120 mm., filler capacity approx. 400 g.
- A solvent recovery unit having reclaiming capacity of approx. 50 l/h, equipped with cooling system foreseen of devices switching ON and OFF the unit to fully automatically perform the test.
- A separate control panel allows to program all these functions in a fully automatic system. It is also possible to select the manual function allowing to activate each specific function previously analyzed.

This unit is supplied complete with:

- Two stainless steel beakers dia. 120 mm
- Four stainless steel sieves dia. 200 mm openings: 0,063 - 0,250 - 0,800 - 2 mm
- One Sieve Frame only dia. 200 mm. to improve the capacity of the first sieve.
- Set of O ring gaskets for sieves.

Sieves with different openings are available on request.

A complete extraction cycle is performed ot in approx. 25 minutes

and the max. quantity of mixture per extraction is 3500 g

Power supply: 400V 3 ph 50 Hz 5,5 kW

Overall dimensions: 1400x680x1820 mm

Total weight: 185 kg

* NOTE: in addition to the perchloroethylene (PCE) or tetrachloroethylene solvent, it is possible to use also the Trichloroethylene (CHCl₃), but as per 2001/59/CE Directive, it is classified "R45", and therefore considered a dangerous solvent. (Toxic and cancer-producing)



B008

ACCESSORY:

B008-11

Lining paper for centrifuge cup.
 Dimensions: 370x200 mm. Pack of 100 pcs.

SPARE PARTS :

- B008-01** Beaker; 120 mm dia., "stainless steel AISI 304 made", with solution heat-treatment
- B008-02** Sieve dia. 200 mm water seal with O ring gasket (when ordering please specify mesh opening).
- B008-05** Sieve frame only , dia. 200 mm
- B008-06** Seal rings, for the Sieves. Pack of 10 pieces.

B008-10

Cabinet with aspirator

It allows housing the automatic bitumen extraction unit, to minimize the diffusion of vapours and toxic solvents in the laboratory.

The structure is anodized aluminium made and safety glass walls.

The unit is supplied with 4 front doors, aspirator centrifugal electric vapour, and appropriate filter group to activated charcoal.

A room with internal height at least 3 m is required.

Power supply: 380V 3ph 1100W

Overall dimensions: 1950x980x2630 mm. Weight: 140 kg approx.

NOTE: It cannot be sold in CE markets



B008-10



B011

Centrifuge extractor 1500/3000 g capacity

STANDARDS: EN 12697-1 clause B.1.5, EN 13108 / ASTM D2172
AASHTO T164A

Used for the determination of bitumen percentage in bituminous mixtures.

It consists of a removable, precision machined aluminium rotor bowl (accessory 1500 or 3000 g capacity), housed in a cylindrical aluminium box.

The separate control panel incorporates an electronic card fitted with AC drive that automatically drives the bowl speed rotation ramp from 0 to 3600 rpm as requested by Standards, with automatic fast stop bowl rotation at the end of the test.

Supplied complete with speed regulator and digital display monitoring the frequency.

The centrifuge is supplied "without" aluminium bowl+cover and "without" filter discs to be ordered separately (see accessories)

The unit cannot be sold in CE markets (see mod. B011-10)

Power supply: 230V 1ph 50-60Hz 550W

Dimensions: 550x380x500 mm approx.

Weight : 50 kg approx.

NEEDED ACCESSORIES:

B010-11 BOWL AND COVER 1500 G. CAPACITY.
Made of precision machined cast aluminium.
Weight: 3,6 kg

B010-15 FILTER DISC, 1500 G. CAPACITY. Pack of 100 pieces.

B010-12 BOWL AND COVER 3000 G. CAPACITY.
Made of precision machined cast aluminium.
Weight: 4,6 kg

B010-16 FILTER DISC, 3000 G. CAPACITY. Pack of 100 pieces.

ACCESSORY:

TRICHLOROETHYLENE SOLUTION FOR BINDER EXTRACTION.
We cannot supply for shipping problems.

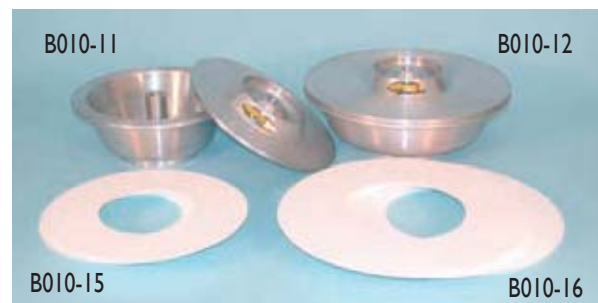

B011

- Accepts bowls both 1500g and 3000g capacity
- Speed control 0-3600 rpm by "inverter" at 50/60Hz
- Separate panel for speed control and rpm on digital display.
- Explosion proof model (B011-01)
- CE safety option (B011-10)

UPGRADING OPTION:

B011-10

SAFETY ELECTROMAGNETIC MICRO-SWITCH SYSTEM to prevent the opening of the cover when the Centrifuge is working, or during the bowl rotation.
Conforming to CE Safety Directive.
Not applicable to the Centrifuge explosion proof version mod. B011-01.



B011-10

B011-01

Centrifuge extractor "explosion proof" 1500/3000 g capacity

Same to mod. B011, but equipped with a special explosion proof electric motor.

The control panel has to be installed in a non explosive area.



B014

Continuous flow filterless centrifuge

STANDARDS: EN 12697-1 all. B.2.1, EN 13108 / DIN 1996
CNR N° 38 / ASTM D1856

Designed for quick filterless separation of filler from binder solution or other mixtures containing sediments (cement, soil, clay), in suspension. As no filter is required, there is no dispersion of material so that the highest accuracy is assured. The solution is poured into the top funnel and falls into the rotating test container dia. 70x200 mm. Because of the centrifugal effect, the liquid rises vertically leaving the filler and mineral particles inside the beaker. The centrifuge is supplied complete with aluminium beaker, two sieves 2 mm and 0,063 mm mesh respectively. The rotation speed is 11500 rpm, with automatic ramp and preset speed control. Extraction capacity is up to 100 g. of filler per test. Power supply: 230V 1ph 50 Hz 600 W
Dimensions: 350x600x720 mm.
Weight: 60 kg

SPARE:

B014-01 ALUMINIUM BEAKER 70 mm. dia. x 200 high

ACCESSORY:

TRICHLOROETHYLENE SOLUTION FOR BINDER EXTRACTION.
We cannot supply for shipping problems.



B014

B021

Solvent recovery still - 10 litre/hour

This efficient and compact unit, easy to install, is totally self contained. It is provided of two tanks: one for the clean solvent and one for the dirty solvent and of a water coolant system which only needs to be connected to a tap. A safety cut out is also supplied, being activated when the solvent level becomes too low or once the process is completed.

Fully stainless steel very high quality (AISI 316) made. Supplied complete of funnel/tank with sieve insert, 10 m plastic tube.

Power supply: 230V 1 ph 50-60 Hz 1300 W

Dimensions: 320x400x650 mm

Weight: 17 kg



B021

- All high quality stainless steel (AISI 316) made with copper coils
- Security devices stopping the unit at the end of the test or in case of overheating

- Filler recovery with filterless system
- Continuous flow at 11500 rpm
- Automatic speed ramp





B016-10

Hot extractor set PAPER FILTER METHOD

STANDARDS: EN 12697-1 clause B.1.1
EN 13108, EN 12697-14
BS 598:102

The unit is used to extract the binder from bituminous mixtures, and to determine the moisture content. Consisting of a metallic pot complete with gauze basket and filter; Dean Stark collector; Liebig condenser; filter paper 400mm dia. (pack of 25 pcs.)
Dimensions: 480x480x900 mm
Weight : 22 kg approx.

ACCESSORY:

V200-02 Hot plate dia. 220 mm.
230V 1ph 50-60Hz 2000W

SPARE PART:

B016-15 Filter paper 400 mm dia. (100 pcs.)

B017 KIT

Hot extraction apparatus

WIRE MESH FILTER METHOD

STANDARDS: EN 12697-1 clause B.1.2, EN 13108 / CNR a.VII N° 38
DIN 1996

This apparatus consists of a cylindrical glass jar containing a stainless steel wire basket cloth opening 0,063 mm. The asphalt sample (max. quantity 400 g) is placed inside the wire basket, the solvent is poured inside the jar. Now the wire basket is inserted into the jar which is covered by a stainless steel condenser connected to a water supply. The apparatus is placed on a hot plate and the boiling solvent drips into the basket dissolving out the bitumen. The filler passing through the mesh basket must be separated using the centrifuge extractor.

Dimensions:
dia. 160x335 mm
Weight: 5 kg

ACCESSORIES:

B017-02 Wire basket stainless steel cloth opening 0,4 mm

B017-04 Wire basket stainless steel, double cloth 0,063 and 0,4 mm. openings.

V200 Hot plate dia. 185 mm
230V 1ph 50-60 Hz 1500W

VI73-03 Wire mesh with ceramic centre

SPARES:

B017-01 Wire basket stainless steel cloth opening 0,063 mm

B017-03 Pyrex glass jar

B017-05 Metal condenser stainless steel with ring



B016-10

B016-20 KIT Soxhelet modified method

STANDARDS:
EN 12697-1 clause B.1.3
EN 13108

Consisting of flask 5000 ml capacity, 2000 ml extractor, cock, vapour tube, condenser; all glass made.

Complete with 25 filtering cartridges dia. 80 x 240 mm, isomantle electric heater, stand and clamps.

Power supply:
230V 1ph 50/60Hz 900W
Dimensions:
400x400x1000 ml approx.
Weight: 20 kg approx.

SPARE PART:

B016-23

Filter cartridges for Soxhelet
dia. 80 x 240 mm
(pack of 25 pcs.)



B016-20 KIT

B061 KIT

Kumagawa (Soxhelet) extractor 1 litre capacity

STANDARDS:
EN 12697-1 clause B.1.3
EN 13108 / LCPC - CNR N.38

Used to extract the bitumen from hot-mixed paving mixtures. Consisting of an electric heating device, balloon 1 litre capacity, glass pipes, cooling unit and 25 filtering cartridges.

Power supply:
230V 1ph 50/60 Hz 750W

B061-01 KIT

Kumagawa (Soxhelet) extractor 2 litres capacity

Basically similar to mod. B061 but 2 litres capacity.

SPARES:

B061-02 FILTER CARTRIDGES, dia. 58x170 mm for Kumagawa 1 litre. Pack of 25 pieces.

B061-03 FILTER CARTRIDGES dia. 80x200 mm for Kumagawa 2 litres. Pack of 25 pieces.



B061 KIT

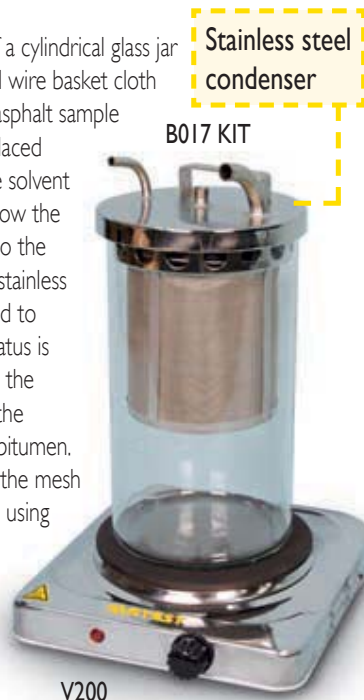

Stainless steel
condenser

B017 KIT

V200

B018

**Binder recovery apparatus.
Vacuum pump method**

**HOT EXTRACTION METHOD
SOLUBLE BINDER CONTENT (BITUMEN RECOVERY)**

STANDARDS: EN 12697-1 Clause B.3.1, EN 13108 / BS 598:102

Used for the separation of solvent from the binder/solvent solution, and to determine the binder content in an aggregate/bitumen mixture. The apparatus consists of:

- Thermostatic water bath to keep boiling water during all the recovery cycle, complete with cover and digital thermostat, inside dimensions mm 280 x 280 xh 230. This unit may be used also as general purposes water bath.
 - Two glass flasks having 250 ml capacity, complete with rubber bungs, tubing and cocks
 - Vacuum gauge (to be connected to the vacuum pump,
 - Pyrex flask, 1000 ml capacity, used as vacuum bottle
- Power supply: 230V 1ph 50Hz 1000W
Weight: 25 kg approx.



NEEDED ACCESSORY:

V203+V205-10

Vacuum Pump to produce a vacuum down 220 mbar; with vacuum regulator. Power supply: 230V 1ph 50Hz. Weight: 5 kg approx.

B018-10

Recovery of binder by Abson method

STANDARDS: ASTM D1856 / CNR N°133

This distillation assembly is used for recovery of binder from a solution of a previous extraction, with properties substantially as those of the bituminous mixture. The apparatus consists of glassware complete set, metallic stand supports, electric heating mantle with regulator. Power supply: 230V 1ph 50/60Hz 750W. Weight: 15 kg approx.



B019 KIT

Reflux extractor 1000 g capacity

STANDARDS: ASTM D2172 / AASHTO T164 B

This simple apparatus, working on the same operation principle of the mod. B017, consists of a cylindrical glass jar containing a metal frame supporting two metal cones of stainless steel cloth and a metal condenser on top of the jar.

Supplied complete with 100 filter papers and wire gauze. Dimensions: dia. 160x510 mm - Weight: 5 kg

ACCESSORY:

V200 Hot plate dia. 185 mm.
230V 1ph 50-60Hz 1500W

SPARES:

- B019-01** Filter paper; pack of 100
- B019-02** Pyrex glass jar
- B019-03** Metal condenser
- B019-04** N° 2 stainless steel cones with frame
- V173-03** Wire mesh with ceramic centre

B020 KIT

Reflux extractor 4000 g capacity

Similar to mod. B019 but having 4000 g capacity. Dimensions: dia. 280x510 mm. Weight: 9 kg

ACCESSORY:

V200-02 Hot plate dia. 220 mm
230V 1ph 50-60Hz 2000W

SPARES:

- B020-01** Filter paper; pack of 100
- B020-02** Pyrex glass jar
- B020-03** Metal condenser
- B020-04** N° 2 stainless steel cones with frame
- V173-04** Wire mesh with ceramic centre
- B020-05** Wire mesh 300 x 300 mm



B067N

Vacuum pycnometer 10 litres capacity

THEORETICAL MAXIMUM SPECIFIC GRAVITY OF UNCOMPACTED BITUMINOUS PAVING MIXTURES (RICE-TEST)

STANDARDS: EN 12697-5, EN 13108 / ASTM D2041 / AASHTO T209, T283

Transparent plexiglass made, complete with valve and gauge, it is utilized for a rapid determination of asphalt content, bulk specific gravity of aggregates, the max. theoretic specific gravity of bituminous uncompact road mixtures and the percent air voids in compacted mixtures.

To perform the test a minimum ultimate vacuum of 30mm/Hg is requested.

Dimensions: 300mm dia. x 450mm high

Weight : 8 kg approx.

B067N



A059-02 KIT

V205-01+
V205-10+V205-12+
V230-03+ B067-11

ACCESSORIES:

A059-02 KIT

VIBRO-DEAERATOR, ELECTROMAGNETIC, with adjustable vibrating intensity.

To vibrate the pycnometer for the evacuation of the air.

This unit can be used also as a Sieve Shaker.

Technical details: see Section "A" Aggregates, pag. 38

V205-01 + V205-10 + V205-12

VACUUM PUMP, PORTABLE TWO STAGES, complete with vacuum regulator and condensed water trap.

Technical details: see Section "V" pag. 487

V230-03 TUBING FOR VACUUM, 3 m long

B067-11 ELASTICS, to fix the pycnometer to the vibro-deaerator:

BINDER RECOVERY BY ROTARY EVAPORATION

B065

Rotary Evaporation Apparatus

STANDARDS: EN 12697-1, 12697-3

This unit is used to recover bitumen from a solvent by minimizing the changes in the asphalt properties.

The test is performed by distilling the residue of the solution of solvent and asphalt.

The rotating distillation flask is partially immersed in a heated oil bath, and the solution is subjected to high vacuum, with fine regulation of pressure (up to +/- 0.1 kPa) according to EN 12697-3 Specification.

The recovered asphalt can be used for further tests, as required.

The Rotary Evaporation Apparatus is essentially composed by:

- distillation flask 1000 ml capacity.
- motor of variable speed, suitable to rotate the flask at an adjustable rate of 20 to 280 rpm.
- condenser.
- solvent recovery flask, 1000 ml capacity.
- heated oil bath.

The angle of the rotary/distillation flask is 15°

The instrument is supplied complete with glass tubing with three way valve and transparent flexible hose for solution intake.

The Rotatory Apparatus requires a vacuum pump and a vacuum regulating system (see accessories).

Power supply: 230V 1 ph 50Hz - Weight: 27 kg approx.

ACCESSORIES:

B065-12 VACUUM REGULATING SYSTEM, including regulation valve, pressure gauge and vacuum digital gauge 1 mbar resolution. - 230V 1 ph 50Hz

V205-01 VACUUM PUMP, dual stage.

Technical details: see pag. 453 - 230V 1 ph 50Hz

V230-03 RUBBER TUBE, lined for vacuum, 3 m long.

B065-14 DIATHERMIC OIL, can of 5 kg

B065-15 EVAPORATION BALLOON, glass, flat, 3 l capacity

B065-13 DISTILLATION FLASK, 2000 ml capacity (ASTM D5404)



B065

B065-12

V205-01+V230-03



B007

ASPHALT SPLITTER

This instrument is used to break and crumble asphalt samples to facilitate bulk density tests and laboratory testing purposes, by reducing the granulating time in few minutes with high quality results.

A rough asphalt sample of approx. 1 kg is poured into the stainless steel bowl equipped, at its bottom, of three rotating paddles. The cover is closed, the machine started, and the three paddles break and crumble the sample in grains.

One to three minutes are normally sufficient to obtain a grained sample, but the longer is the grinding time, the more grain sizes will decrease. The bowl is now tilted to discharge the sample into the self supporting suitable pan supplied with.

A hinged cabinet reducing noise protects the bowl. When opening the cover while the splitter is working, a microswitch automatically stops the machine, conforming to CE Safety Directive.



TECHNICAL SPECIFICATIONS:

- Stainless steel bowl 6 litres capacity
- Multirange timer: sec/min/hour
- Main switch, Start/Stop button
- Switch for reverse mode of the rotating paddles
(very useful when the material restrains between paddle/bowl)
- Paddles speed: 1400 rpm
- Power supply: 230V 50Hz 1500W
- Dimensions: 490 x 730 xh 855 mm
- Weight: 85 kg approx.

SPARE PART:

B007-11

Kit of three rotating paddles with screws.



B007
Unloading phase

B007 Open



B068

B068

Moisture Induced Stress Tester

STANDARD: ASTM D7870

Proper testing and screening of Hot Mix Asphalt (HMA) mixes for moisture susceptibility is a crucial requirement for designing today's high-performing, longer-lasting pavements. This product is designed to simulate HMA pavement asphalt stripping mechanisms, which are due to water and repeated traffic loading. Current moisture sensitivity tests suffer from poor repeatability and test times can take up to seven days. HMA conditioning in the instrument is automatic and can be completed in less than a day.

Plug the unit into a standard wall outlet, place the sample in the chamber, select your settings and the unit does the rest. The device creates pressure cycles within the chamber to simulate the effect of moisture on the asphalt mixture. The data from the unit can be stored and transferred to a PC for evaluation and storage.

Temperature Accuracy: ± 1 °C

Pressure Accuracy: 0.25%

Power supply: 230V 1ph 50Hz 1650W

Dimensions: 1210x1210x1570 mm.

Weight: 226 kg



PARTICLE LOSS OF POROUS ASPHALT SPECIMEN

STANDARDS: EN 12697-17, EN 13108

The test concerns the determination of the particle loss by abrasion of porous asphalt mixtures.

RESISTANCE TO FUEL

STANDARDS: EN 12697-43, EN 13108

The test concerns the determination of the resistance of a pavement or a bituminous mixture to aviation fuel.

These two Standards require, within other specific tests, the abrasion tester:

A075N Los Angeles abrasion machine

Technical details:
see Section "A"
Aggregates, pag. 45



A075N

DETERMINATION OF THE AFFINITY BETWEEN AGGREGATE AND BITUMEN

STANDARDS: EN 12697-11, EN 13108

The equipment is formed by:

B022

Bottle rolling machine, with rotation speed adjustable from 0 up to 85 rpm, used for the determination of the affinity between aggregate and bitumen, expressed by visual registration of the degree of bitumen coverage on uncompacted bitumen-coated mineral aggregate particles after influence of mechanical stirring action in the presence of water. The machine can roll up to 3 bottles at the same time. Supplied complete with timer range 0 - 6 hours.

Power supply:

230V 50/60Hz 1ph

Dimensions:

385x295x160 mm.

Weight: 10 kg approx.



B022 + B022-11

B022SP

Bottle rolling machine, same to mod. B022 but equipped with timer range 0 - 99 hours.



B022-12

B022-11

B022-11

TEST BOTTLE, made of borosilicate glass, 500 ml capacity, diameter 86 mm, height 176 mm, as expressly requested by EN Specification.

B022-12

GLASS ROD with a diameter of 6 mm equipped with 35 mm long fitting rubber tube.

SAMPLING OF ASPHALT ROAD CORES FOR THE DETERMINATION OF PHYSICAL PROPERTIES AND COMPOSITION

STANDARD: EN 12697-27

C319 Pavement core drilling machine

Technical details, other models of machines, coring bits etc. described in section "C" pag. 280

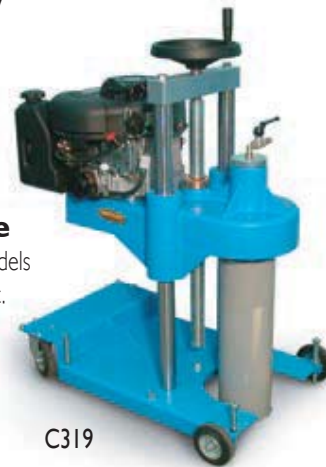

C319

VIBRATORY COMPACTION METHOD, FOR THE PREPARATION OF BITUMINOUS TEST SPECIMENS, applicable to loose mixtures and cores to determine a density ratio for a bituminous mixture as described in the EN Specifications.

STANDARDS: EN 12697-9, 12697-10, 12697-32 / BS 598:10

B097

P. R. D. MOULD, vertically split on one side, foreseen of clamp attachment to the base plate, plated against corrosion, is utilized for determining the degree of compaction of bituminous pavements, for quality control purpose.
Weight: 12 kg



B097-12

B097-11

B097-12

B097

S197N

VIBRATING HAMMER, double insulated motor; trigger handle, for asphalt compaction in the percentage refusal density test. It can be used also for the compaction of Proctor and CBR specimens
Technical details: see Section "S" pag. 404

ACCESSORIES:

B097-11 Small tamping foot, dia. 102 mm
Complete with shank.

B097-12 Large tamping foot, dia. 146 mm
Complete with shank.

S197-01N Supporting frame for vibrating hammer (see pag. 404).



INDENTATION TEST USING CUBES OR MARSHALL SPECIMENS

STANDARDS: EN 12697-20, EN 13108

This EN describes a test method for determining the depth of indentation of mastic asphalt and rolled asphalt, when force is applied to them via a cylindrical indenter pin with a circular flat-ended base. The test applies to aggregates of maximum nominal size less or equal to 16 mm

This test method is performed on mastic and road constructions asphalts, on waterproofing and floor screeds in building constructions.

The indentation test can be applied also on Marshall specimens. Condition the specimens together with their moulds for at least 60 min under water at the test temperature of 40°C. or 22°C. respectively with +/- 1°C. accuracy.

B059-10 Asphalt indentation penetrometer

Comprising:

- Rugged basic frame where the screw penetration load device is fixed.
- Two interchangeable penetration pistons having 1 and 5 cm² surface.
- Two metallic discs having total weight of 500 N (51 kg) that are positioned on the load device.
- Dial gauge 30 mm, sens. 0,01 mm to measure the penetration.
- Stainless steel water bath complete with water discharge cock. Heater, cube mould, test mould, "are not included" and have to be ordered separately (see accessories).

Dimensions: 530 x 600 xh 820 mm

Weight: 160 kg



B059-21

B059-15



B059-18



B059-16



B059-17



B059-10



ACCESSORIES:

B059-15

CUBE MOULD 70,7 mm.

To prepare cube specimens.

Steel manufactured, it is easily detachable. Weight: 4350 g

B059-16

PENETRATION (ADJUSTABLE) TEST MOULD 69 mm.

Used during the penetration test of the cube specimen.

Made from aluminium alloy. Weight: 1850 g

B059-17 BASE, steel made, to fix the Marshall specimen into the

Penetrometer. Weight: 1100 g

B059-18 CALIBRATION DEVICE for the Indentation Penetrometer.

Weight: 700 g

B059-21

THERMOSTAT DIGITAL HEATING SYSTEM, complete with immersion heating element.

It heats water at the required temperature of 22°C. or of 40°C.

with an accuracy within +/- 1°C. as requested by Standards.

Power supply: 230V 1ph 50Hz 1500W

Weight: 3 kg. Approx.

BITUMINOUS MIXTURES TEMPERATURE MEASUREMENT

STANDARD: EN 12697-13

V154

Digital microprocessor thermometer

Range : -50 +950°C., resol. 0,1 – 1°C.

Supplied "without" probes to be ordered separately (see accessories).

Technical details: see section "V" pag. 480



V154

ACCESSORIES:

V154-01 Penetration probe, 120 mm long

V154-02 Surface probe, 260 mm long



BINDER DRAINAGE, BASKET METHOD

To determine the drainage of bituminous samples obtained from different mixtures of mineral fine aggregates or additives, for the evaluation of the drainage results.

STANDARDS: EN 12697-18, EN 13108

B022-20

Drainage basket, dimensions 100x100x100 mm, made from stainless steel sheet with 3,15 mm dia. holes.
Weight: 500 g approx.



B022-21

Tray, stainless steel made, dimensions 160x160x10 mm.
Weight: 500 g aprox.

B024-10

Radial-flow falling head permeameter

STANDARD: EN 12697-40

Used to determine the time taken for 4 liters of water to dissipate through an annular area of the surfacing of a pavement under known conditions.

Consisting of:

- acrylic tube 125 mm inside diameter, 560 mm long, marked at 1 liter and at 5 liters
 - internal rod with rubber ball valve
 - wooden base with sealing gasket
- Dimensions: 800x450x680 mm
Weight: 7 kg approx.



B024-05

Conical sieve 0,355mm mesh

STANDARD: EN 15366:2010

Used to verify the absorption degree of mineral oils and hydrocarbons from granulate products spread on the road during winter time.



B024

Permeameter

FOR DRAINING PAVEMENTS IN SITU.
STANDARD: ITALIAN HIGHWAY SYSTEM, COMPARABLE TO MPW OF BELGIUM

Mainly used in situ to perform and to check the permeability and drainage on road carpets, concrete pavements, tamped earth etc. The test consists in filling the cylinder with water, after ermetically positioning it on the carpet under test and then in calculating the time needed by a certain quantity of water to be absorbed by the same. The instrument is composed of a bottomless plexiglass cylinder 140 mm inside diameter, fitted on a base. The cylinder has two black calibration lines: one at zero point and one at 250 mm.
Dimensions: 260x260x425 mm
Weight: 8 kg



ACCESSORY:

B024-01

WEIGHT KG 5, annular shape, to apply on the base of the permeameter; to improve its adherence to the material under test.



DETERMINATION OF BULK DENSITY OF BITUMINOUS MIXTURES BY HYDROSTATIC GRAVITY METHOD

STANDARDS: EN 12697-6, 12697-7, EN 13108

ASTM D1186, D2726

AASHTO T166-93 / CNR N. 40

V085

Specific gravity frame

Used for specific gravity determination of materials, and specifically the bulk density of laboratory compacted asphalt specimens and asphalt road cores.

Technical details:
see section "V" pag. 472



ACCESSORIES:

V041

DENSITY BASKET, stainless steel, 200 mm dia. by 200 mm high

V075-11

DIGITAL BALANCE 6000g capacity x 0,1g sens.
Technical details and other models: see section "V" pag. 471

A106

WAX MELTING POT

Technical details:
see section "A" pag. 29



V300-19

PARAFFIN WAX, pack of 5000 g

LABORATORY BITUMINOUS MIXERS

AVAILABLE MODELS:

E094

Mixer 5 litres capacity

STANDARD: EN 12697-35 / BS 598:107

This bench mounting Mixer, is utilized for mixing samples of bituminous materials. Thanks to its double mixing action (shaft and planetary) it ensures uniform mixing. Two speed can be selected:

140 or 285 rpm for the revolving action

62 or 125 rpm for the planetary action.

The mixer is supplied complete with stainless steel bowl, but "without" whisk to be ordered separately (see accessories).

It cannot be sold in CE markets without security guards (see mod. E095).

Power supply: 230V 1 ph 50 Hz 800 W

Dimensions: 450x400x480 mm

Weight: 50 kg



E094 + B028-03

E095

Mixer 5 litres capacity

Same to mod. E094 but equipped with security guards, conforming to CE Safety Directive.

Note: The proper utilization of the mixers mod. E094 and E095 requires to heat the bowl with the bituminous sample at the temperature specified by the Standards. To this purpose a common laboratory oven is used, and the sample mixing (time: approx 2 minutes) is performed immediately after having taken off the bowl from the oven. As an alternative to this procedure the heater mod. B028-01 can be used.



B028-03

E095-03



E095-01

B028-01



E095 + B028-03

ACCESSORIES FOR E094 and E095:

B028-03 WHISK BEATER, thin wire, stainless steel, to EN Spec.

B028-01 ISOMANTLE ELECTRIC HEATER, complete with thermoregulator: Power supply: 230V 1 ph 50-60Hz 800W

E095-03 BEATER, stainless steel made.

SPARE: **E095-01** BOWL, stainless steel, 5 litres capacity.



...follows...

Mixer 20 and 30 litres capacity

STANDARD: EN 12697-35

These large capacity mixers have been designed to mix bituminous samples for compaction tests, Marshall and tensile splitting test and for other tests where uniformity is required. Thanks to the planetary action this mixer ensures a complete and uniform mixing. The machine is provided with a variable speed drive allowing to set a wide range of speeds:

- from 20 to 130 rpm for the planetary action
- from 60 to 390 rpm for the revolving action

The stainless steel cover can be lifted to inspect the bowl, and in this case the motor automatically turns off to prevent accidents to CE safety Directive.

A timer allows to select the mixing time or the continuous mixing.

The mixer is supplied complete with stainless steel bowl, but "without" whisk beater, "without" coupling and "without" electric heater that must be ordered separately (see accessories).

AVAILABLE MODELS:

B027 MIXER, 20 LITRES CAPACITY

Power supply: 400V 3ph 50Hz 1,1kW
Dimensions: 489x693xh 944 mm
Weight: 110 kg approx.

B027SP MIXER, 20 LITRES CAPACITY

Identical to mod. B027 but with power supply: 230V 1ph 50Hz 1,1kW

B027L MIXER 30 LITRES CAPACITY

Identical to mod. B027, but with bowl capacity of 30 litres.
Power supply: 400V 3ph 50Hz 1,1kW
Dimensions: 700x539xh944 mm
Weight: 120 kg approx.

B027LSP MIXER 30 LITRES CAPACITY

Identical to mod. B027L, but with power supply: 230V 1ph 1,1kW

ACCESSORIES:

MODEL:

WHISK THIN wire beater; EN Specifications
WHISK THICK wire beater; EN Specifications
COUPLING beater/shaft for B027-03(L), B027-06(L), B027-04(L)

OTHER MODELS OF BEATERS, NOT CONFORMING TO STANDARDS:

BEATER, STAINLESS STEEL
BEATER, aluminium
SPIRAL Beater
HOOK Beater
COUPLING beater/shaft for B027-02(L), B027-05(L), B027-07

ISOMANTLE HEATER, electric, complete with thermoregulator.

The isomantle winding action of the bowl allows a more uniform heating of the bituminous sample.

Power supply: 230V 1ph 50/60Hz 1000W

BOWL, Stainless Steel, spare-part



| MODEL: | B027 (20 litres) | B027L (30 litres) |
|--|------------------|-------------------|
| WHISK THIN wire beater; EN Specifications | B027-03 | B027-03L |
| WHISK THICK wire beater; EN Specifications | B027-06 | B027-06L |
| COUPLING beater/shaft for B027-03(L), B027-06(L), B027-04(L) | B025-08 | B025-08L |
| OTHER MODELS OF BEATERS, NOT CONFORMING TO STANDARDS: | | |
| BEATER, STAINLESS STEEL | B027-07 | ----- |
| BEATER, aluminium | ----- | B027-02L |
| SPIRAL Beater | B027-04 | B027-04L |
| HOOK Beater | B027-05 | B027-05L |
| COUPLING beater/shaft for B027-02(L), B027-05(L), B027-07 | B025-09 | B025-09L |
| ISOMANTLE HEATER, electric, complete with thermoregulator. | | |
| The isomantle winding action of the bowl allows a more uniform heating of the bituminous sample. | | |
| Power supply: 230V 1ph 50/60Hz 1000W | B027-01N | B027-01L |
| BOWL, Stainless Steel, spare-part | B027-11 | B027-11L |



B026N

PaveMix - Matest made

Automatic Asphalt Large Laboratory Mixer, 32 litres capacity

STANDARD: EN 12697-35 / ASTM D6307 / AASHTO TP53

The PaveMix has been expressly designed to prepare homogeneous bituminous mixtures at a strictly controlled temperature. The preparation of the bituminous sample is obtained in a short time period (few minutes) to avoid any mechanical aggregate degradation and to fully coat all mineral components, as requested by EN 12697-35.

The mixer produces representative samples to perform:

- Gyratory compaction tests (EN 12697-10, EN 12697-31)
- Marshall stability tests (EN 12697-34, EN 13108)
- Wheel tracking wet and dry tests (EN 12697-22)
- Slabs compaction laboratory tests (EN 12697-33)
- Beam fatigue and Stiffness tests (EN 12697-26, EN 13108)
- Asphalt general purpose tests.

PaveMix consists of:

- Main frame holding a horizontal stainless steel bowl with a helical mixing shaft.
- The bowl, double wall insulation made of stainless steel AISI 316, contains an electric heater with probe sensor granting constant and uniform temperature control.
- An electromechanical motion allows to tilt the bowl to get easy the unloading operation.

The control panel foresees:

- Digital thermo regulator to set temperature and to control the mixing temperature.
- Mixing speed regulator.
- Main and start/stop switches.
- Command to tilt the bowl.

Technical Specifications and features:

- Mixing capacity: 32 litres max.
- Mixing bowl: stainless steel AISI 316
- Mixing temperature: selectable from ambient up to 260°C through sensitive probe and digital display control.
- Mixing speed: adjustable from 4 to 40 rpm.
- Easy tilting unloading operation by electromechanical motion.

Heating power: 3000 W

Power supply: 230V 1ph 50/60Hz 4500 W

Dimensions: 1280 x 700 x h1210 mm

Weight: 350 kg



Bowl detail: open and tilted



HOT MIX ASPHALT COMPACTABILITY DETERMINATION

B031NI

Marshall Automatic EN (impact) Compactor

STANDARDS: EN 12697-10 / EN 12697-30:2012 comparable to: BS 598:107

This ruggedly constructed apparatus automatically compacts the bituminous sample and stops off the motor after the preset number of blows has been completed on the automatic digital display counter.

The trip mechanism is structured so that the sliding hammer falls at the same height at every blow.

The mould is held in position by a fast clamping device.

The compactor includes a vibrated concrete base where a laminate hardwood block is mounted.

Total weight of the compaction hammer (Rod + Foot + Sliding mass): 7850 ± 50 g

Sliding mass weight: 4535 ± 15 g

Free fall height: 457 ± 5 mm

Blow frequency: 50 blows in 55/60 seconds

The machine is equipped with safety door, conforming to CE Safety Directive.

When opened it stops automatically and cannot operate.

All moving parts are quickly/easily accessible for maintenance.

The compactor is supplied complete, "except for the mould" that must be ordered separately.

Power supply: 230V 1ph 50Hz 300W

Dimensions: 500 x 500 x 1890 mm

Weight : 220 kg

ACCESSORY:

B031-01

CABINET, lined with sound-proofing material for noise reduction within CE limits

Dimensions:

800 x 800 x 2000 mm approx.

Weight : 100 kg approx.

SPARE PART:

B033-11N

Compaction Hammer complete

B029N-KIT

Marshall compaction mould, 4" dia.

STANDARDS: EN 12697-10 / EN 12697-30:2012

CNR N° 30 / NF P98-251-2

Inside diameter: 101,6 mm (4")

Steel manufactured, plated against corrosion.

Weight: 3,150 kg

Consisting of:

B030N MOULD BODY only. Weight: 1300 g

B030-01N FILLING COLLAR only. Weight: 850 g

B030-02N BASE PLATE only. Weight: 1000 g

Note: French NF P98-251-2 Spec. requires the filling collar with a small different dimension, but fitting perfectly the mould body and the baseplate.



B031NI + B031-01



B031NI

B030-01NF FILLING COLLAR only (NF P98-251-2).

Weight: 850g

B030-03

EXTRACTION PLATE, to eject specimens from the mould.

It is used in conjunction with B030-04 receiver. Weight: 1400 g

B030-04

SPECIMEN RECEIVER, used to receive the specimens ejected by the B030-03 extruder.

Weight: 1300 g

B030-05 FILTER DISC dia 100mm. Pack of 100

B031-08 DISTANCE PIECE, (to use of the B029N-KIT mould with the old Compactors model B031 and B031N).

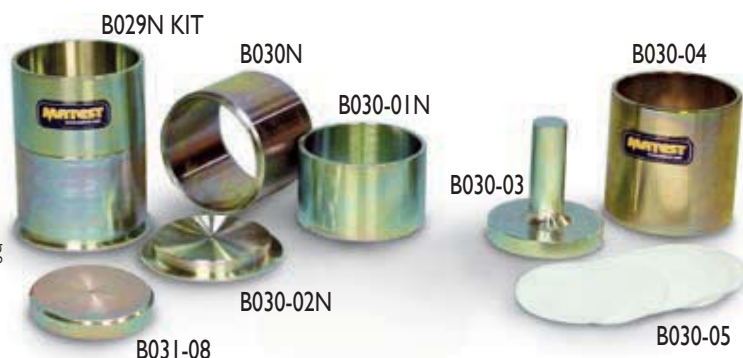

B029N KIT

B030N

B030-01N

B030-04

B030-03

B030-02N

B031-08

B030-05



MARSHALL STABILITY ASTM - SPECIMEN COMPACTION

B033

Automatic Marshall compactor for 4" Ø moulds

STANDARDS: ASTM D6926 / Comparable to AASHTO T 245

This ruggedly constructed machine has been designed to eliminate the laborious process of hand compaction. It automatically compacts the specimen and stops off the motor after the preset number of strokes has been completed on the automatic digital display counter. The trip mechanism is structured so that the hammer falls at the same height at every stroke. The unit incorporates a compaction wooden pedestal. The drive mechanism lifts the 4,53 kg, compaction hammer, plated against corrosion, to the height of 457 mm, and allows free fall at 60 blows per minute.

This compactor is suitable only for Marshall moulds dia. 4".

The compactor is supplied complete "except" for the mould which must be ordered separately. It cannot be sold in CE markets without safety guards (see mod. B033-01 and B033-03)

Power supply: 230V 1 ph 50Hz 300 W

Dimensions: 540x400x1600 mm

Weight: 95 kg



B033

section B



B033-01

Automatic Marshall compactor for 4" Ø moulds

Same to mod. B033, but equipped with safety guard, conforming to CE Safety Directive.

When opening the guard during Compactor working, a microswitch automatically stops the unit.



B033-01



B033 + B033-03



B033-11

B033-04

ACCESSORIES:

B033-03

SOUNDPROOF SECURITY CABINET, steel made with micro-switch, complying to CE Safety Directive, lined with sound-proofing material for noise reduction.

Accessory for B033 model.

If the door is opened while the Compactor is working, it automatically stops.

Dimensions: 660x660x1900 mm

Weight: 70 kg approx.

B033-04 STEEL PLATE, dia. 100x50 mm, to heat the Compaction's Hammer.

SPARE:

B033-11 COMPACTION HAMMER complete for B033, B033-01 Compactors.



B032-KIT
Marshall compactor, hand operated for 4" Ø moulds

STANDARDS: ASTM D6926
 AASHTO T245

Similar to mod. B033, but the hammer is lifted and released manually.
 Dimensions: 320x320x1600 mm
 Weight: 60 kg approx.

The assembly consists of:

B034
 COMPACTION HAMMER, with 4,53 kg sliding weight, guided on a shaft.
 Plated against corrosion
 Weight: 10 kg

B036
 COMPACTION PEDESTAL, consisting of a wooden block, capped with a steel plate.
 Complete with mould clamp device.
 Plated against corrosion.
 Weight: 42 kg

B037 SUPPORT and hammer guide.



B035-01
Automatic Marshall compactor for 6" and 4" Ø moulds

STANDARDS: ASTM D6926, D5581 / Comparable to AASHTO T245
 This apparatus automatically compacts the Marshall specimens 6" and 4" diameter and stops after the preset number of blows.
 Supplied complete, "except for the compaction hammers 6" diameter (mod. B035-11) and 4" diameter" (mod. B035-12), and the moulds, which must be ordered separately.
 It cannot be sold in CE markets without safety guards (see mod. B035-02 and B035-03). Power supply: 230V 1ph 50Hz 500W
 Dimensions: 460x570x1700mm. Weight: 180 kg approx.

B035-02
Automatic Marshall compactor for 6" and 4" Ø moulds

Same to mod. B035-01, but equipped with safety guards, conforming to CE Directive.

B032-01
Marshall compactor, hand operated, for 6" and 4" Ø moulds

STANDARDS: ASTM D6926, D5581
 Comparable to AASHTO T245
 Supplied complete with compaction hammer 6" diameter, wooden pedestal capped with steel plate and mould clamp device, support/hammer guide.
 Dimensions: 320x320x1700mm
 Weight: 70 kg approx.

ACCESSORIES:

B034
 COMPACTION HAMMER 4" diameter, complete, for B032-01 Compactor.

B032-11
 REDUCTION COLLAR to fix the mould B029KIT (4" dia.) to the Marshall Compactor mod B032-01

SPARE PART:

B032-05
 COMPACTION HAMMER 6" diameter, complete, for B032-01 Compactor



B032-05



B034



B035-11

B035-12



B035-01

ACCESSORIES:

B035-11 COMPACTION HAMMER 6" diameter for the B035-01 and B035-02 Compactors.

B035-12 COMPACTION HAMMER 4" diameter for the B035-01 and B035-02 Compactors.

B035-03 SOUNDPROOF SECURITY CABINET, steel made, lined with sound-proofing material, complying to CE Safety Directive.



B032-11

B032-01

B030 KIT

Marshall compaction mould, 4" Ø

STANDARDS: ASTM D6926 / Comparable to AASHTO T245
 Inside diameter 101,6 mm (4")
 Steel manufactured, plated against corrosion.
 Weight: 3100 g

Consisting of:

B030N MOULD BODY only. Weight: 1300 g

B030-01N FILLING COLLAR only. Weight: 850 g

B030-08 BASE PLATE only. Weight: 950 g

ACCESSORIES:

B030-03

EXTRACTION PLATE, to eject specimens from the mould. It is used in conjunction with B030-04 receiver.
 Weight: 1400 g

B030-04

SPECIMEN RECEIVER, used to receive specimens ejected by the B030-03 extruder.
 Weight: 1300 g

B030-05 PAPER DISC dia. 100 mm. Pack of 100.

B030-06 BASE PLATE with handles
 (alternative to mod. B030-08)

B029-01

Marshall compaction mould, 6" Ø

STANDARD: ASTM D5581-96
 Consisting of mould body, filling collar and baseplate.
 Inside diameter: 152,4 mm (6")
 Steel manufactured, plated against corrosion
 Weight: 5 kg approx.

S114

Universal extruder

Hand operated, actuated by a 5 tons hydraulic jack, it is designed to extrude samples having dia. 4" and 6". It can therefore extrude Marshall, CBR, Standard and Modified Proctor specimens.
 Dimensions: dia. 300x500 mm
 Weight: 30 kg



B079N

Cabinet with aspirator

Double aspiration system, certified to EN 14175-2-3 Bureau Veritas. Used to exhaust vapors and toxic solvents caused by Centrifuge Extractors, Hot Extractors etc., by avoiding they are diffused in the laboratory.

Metal frame, monolithic stoneware, 4 sockets + switch, water spout and cock, electric aspirator, electric lighting.
 The front transparent door can be lifted by vertical counterweights for an easy access to the operation desk.

Power supply:
 230V 1ph 50Hz
 Dimensions:
 1800x830xh2500 mm
 Weight: 380 kg



ACCESSORY:

B079-01

LOWER CUPBOARDS, bilaminated plastic made, complete with doors and shelves.

B079-01 →



section B



B041

GYROTRONIC - Superpave Gyrotory Compactor, Matest made

STANDARDS: EN 12697-10, EN 12697-31 / ASTM D6925 / AASHTOT312 / SHRP M-002

This Gyrotory Compactor, entirely developed and manufactured by Matest, is used to simulate and reproduce the real compaction conditions under actual road paving operations, hence determining the compaction properties of the asphalt. Such compaction is achieved in a fully automatic way, by combining the rotary action and the vertical resultant force applied by a mechanical head.

The Compactor comprises a highly rigid steel frame ensuring excellent angle control.

Load is applied by an electro-pneumatic cylinder, servo-controlled by a precision pressure regulator; the height is measured by a linear transducer.

Gyrotory motion is generated by an eccentric high precision system allowing an easy set up with precision and constant angle of gyration. The rotation speed is controlled by an inverter through on board computer control.

Using the proper perforated mould, the Compactor is able to run tests also on cold emulsified asphalt mix.

The acquired results are also employed in the investigation of volumetric and mechanical characteristics of the asphalt mix.

The machine is calibrated at Matest factory with the internal angle set according to the Standard chosen by the customer:

- Angle set to 1,16° to meet ASTM D6925, AASHTO T312, SHRP M-002
- Angle set to 0,82° to meet EN 12697-10, EN 12697-31

NEW

section B



88

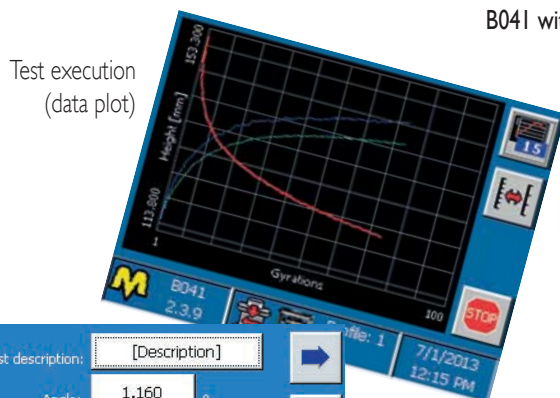

Setting of test parameters

| | | |
|-------------------|---------------|-----|
| Test description: | [Description] | ▶ |
| Angle: | 1,160 | ◀ ▶ |
| Load: | 10,600 kN | ▶ |
| Speed: | 30,000 Rpm | ▶ |
| Cycles: | 100 | ▶ |
| Mould: | ∅150 | ▶ |

M B041 2.0.0 Profile: 1 2/2/2012 9:06 AM

B041 with mould



MAIN FEATURES:

- Highly rigid steel frame ensuring excellent angle control, to meet the strict tolerances requested by EN Specifications.
- Electro-pneumatic action with servo-controlled regulator.
- Electronic control unit with touch screen color display, that runs like a standard PC based on Windows operating system.
- Software for acquisition and PC data processing.

The touch-screen icon interface allows an easy set up of the parameters and immediate automatic execution of the test, data acquisition, processing, graphics and file.

Direct connection to Intranet (connection to a LAN network) and Internet to establish a remote communication and receive an immediate diagnostic analysis of the potential problem from Matest technicians, or for software updates.

Unlimited memory storage with: 2 USB ports, 1 SD card.

Hardware technical details: see catalogue at page 24.

MATEST

TECHNICAL SPECIFICATIONS:

- Compacted specimen size: dia 100 and 150 mm; height from 0 to 200 mm for both sizes.
- Mould dimensions: Internal dia 100 and 150 mm; height 250 mm for both moulds.
- Gyrotory angle: adjustable from 0 to 2,4°
- Number of cycles (gyrotory): adjustable from 1 to 5000
- Gyration rate: adjustable from 5 to 60 work cycles/min (30 cycles/min requested by Standards)
- Vertical load on 150mm dia specimen: adjustable from 10 to 900 kPa (900 kPa with 9 bar compressor) (800 kPa with 8 bar compressor) (700 kPa with 7 bar compressor)
- Vertical load on 100 mm dia specimen: adjustable from 23 to 1500 kPa (with 7 bar compressor)
- The vertical load on the specimen is automatically controlled and adjusted by the electronic system.

Modes of operation:

- Compaction of specimen in accordance to the selected number of rotations.
- Compaction of specimen upon reaching the selected height.
- Compaction of specimen upon reaching the selected density.
- **The machine can also perform a final fluttering cycle at “zero” angle to obtain specimens with perpendicular faces.**

Data acquisition: number of rotations, specimen height, applied load (to assure tolerances requested by the Standards)

Requires pressurized air; minimum 7 bar.

The Matest Gyrotory Compactor is **supplied complete** with lubricant and power cord.

Optional extra are: moulds, filter paper, penetration pistons, extruder, bench, air compressor etc., to be ordered separately (see accessories)

Power supply: 230V 1ph 50/60 Hz 1000W 12A

Dimensions: 640x500xh1050mm

Weight: 240 kg

AVAILABLE MODELS:

B041

Gyrotory compactor - ASTM

STANDARDS: ASTM D6925 / AASHTO T312 / SHRP M-002

The machine is calibrated at Matest factory and supplied with the internal angle set to 1,16° as requested by ASTM, AASHTO Specifications.

B041EN

Gyrotory compactor - EN

STANDARDS: EN 12697-10, EN 12697-31

The machine is calibrated at Matest factory and supplied with the internal angle set to 0,82° as requested by EN Specifications.

Gyrotory compactor with shear stress measurement device

This model is basically structured as mod. B041 and B041EN, but, in addition, **“it includes the shear stress measurement device”** and therefore it is recommended for both design and research purposes.

MAIN FEATURES:

- The device provides the most important parameters required to determine the main properties of asphalt mixes, and to predict their suitability for practical uses.
- Useful for research purposes and experimental studies, and increasingly being considered as a “needed accessory” in most of the worldwide markets.
- A group of load cells (integrated into the Gyrotory Compactor’s frame) measure all the involved forces acting on the specimen, which are analyzed by the software in order to calculate the effective shear stress value.
- Real time visualization of the instant shear stress value along the entire compaction process.
- Calculation of the resultant load’s eccentricity and consequently the effective tilting moment.
- Possibility to export the results into an Excel data report, which can be easily edited by the operator.

ADVANTAGES:

- The shear stress measurement device is integrated into the Gyrotory Compactor and therefore it doesn’t require any additional operation to be done by the user.
- The system comes already calibrated from the factory.
- Available either with ASTM configuration (internal angle: 1,16°) or EN configuration (internal angle: 0,82°).

AVAILABLE MODELS:

B041-01

Gyrotory compactor with shear stress measurement device - ASTM

STANDARDS: ASTM D6925 / AASHTO T312 / SHRP M-002

The machine is calibrated at Matest factory and supplied with the internal angle set to 1,16° as requested by ASTM, AASHTO Specifications.

B041-01 EN

Gyrotory compactor with shear stress measurement device - EN

STANDARDS: EN 12697-10, EN 12697-31

The machine is calibrated at Matest factory and supplied with the internal angle set to 0,82° as requested by EN Specifications.

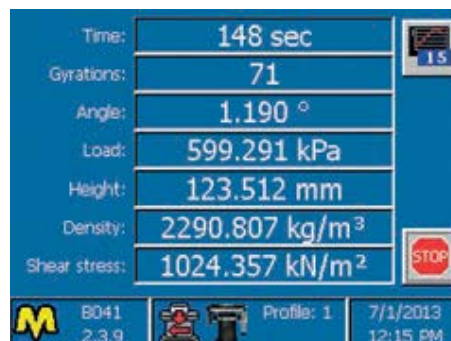

Test execution with shear stress measurement



BITUMEN - ASPHALT

ACCESSORIES to perform the test:

- B041-05** Hardened specimen cylinder 100 mm dia complete with bottom plate
- B041-06** Hardened specimen cylinder 150 mm dia complete with bottom plate
- B041-08** Hardened specimen cylinder 100 mm dia with holes for cold mix compaction, complete with bottom plate
- B041-09** Hardened specimen cylinder 150 mm dia with holes for cold mix compaction, complete with bottom plate
- B041-11** Top penetration piston 100 mm dia
- B041-12** Top penetration piston 150 mm dia

Metallic discs, to make easier the handling of specimens after the test, strongly recommended accessory for low-cohesion mixtures, such as draining asphalts:

- B041-13** Metallic disc for 100mm dia moulds. Pack of 2
- B041-14** Metallic disc for 150mm dia moulds. Pack of 2

Paper discs, to prevent asphalt from sticking to the piston and the mould's base plate, and to absorb bitumen in excess:

- B041-15** Filter paper for 100mm dia moulds. Pack of 100
- B041-16** Filter paper for 150mm dia moulds. Pack of 100

Hollow Punches for Gyrotory Compactor:

Used to maintain the core in the right shape and store cohesive asphalt samples after compaction.

Some asphalt mixes can be very unstable due to their high void ratio and large particle size. Wrapping the sample around the hollow punch will prevent it from crumbling down or receiving physical deformations once it is ejected from the mould. The material will then settle down and assume its stiff properties once it cools down after compaction:

- B041-17** Hollow Punch to stabilize and to mature the sample 100 mm dia.
- B041-18** Hollow Punch to stabilize and to mature the sample 150 mm dia.

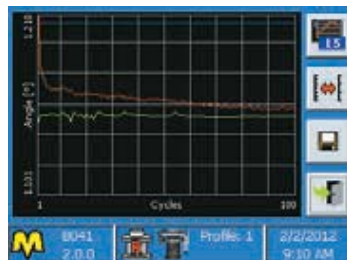

Test data plot



B041-23 extruder with mould



B041-08

B041-09

ACCESSORIES for the Gyrotory Compactor:

- V207** Air Compressor, pressure 10 bar. Technical details: see page 454
- B041-35** Filter group for condensed water removal from the compressed air. **(Necessary Accessory)**.
- B041-20** Worktop for B041 and B041 EN, it can also accept the pneumatic specimen extruder (B041-23) and the integrated balance (B041-26)
- B041-19** Worktop for B041-01 and B041-01 EN, it can also accept the pneumatic specimen extruder (B041-23) and the integrated balance (B041-26)
- B041-23** Pneumatic automatic specimen extruder; it can be fixed to the worktop B041-20, or to any bench.



B041-05

B041-06



B041-26

BALANCE, "integrated" into the worktop, to facilitate the sample and the mould weightings, by avoiding the stress of lifting them.

The weighting reading values are directly and automatically displayed on the control panel of the Compactor:

Capacity: 30 kg
Accuracy: +/- 6 g

As alternative:

B041-27

BENCH for lateral bearing of a weighting balance.

Suggested balances:
V075-13 Capacity 30kg div. 0,5g
or:
B041-24 Capacity 30kg div. 0,1g
as requested by EN
(or a balance of the customer)



B041-21

WHEELS (kit of 4) with brake, for an easy displacement of the Compactor in the laboratory.



section B



Test configuration (balance)

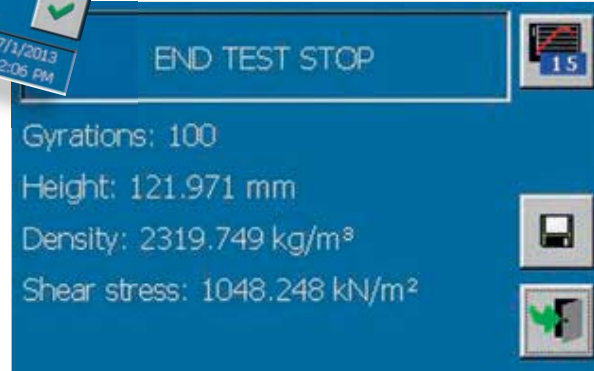

End test data (with shear stress value)



B041-30 Vertical force testing device with load ring.

As alternative:

B041-31 Vertical force testing device with digital dynamometer.



B041-33

Kit of 2 distance pieces of 105 and 115 mm high for the control of the height values measured by the linear transducer.

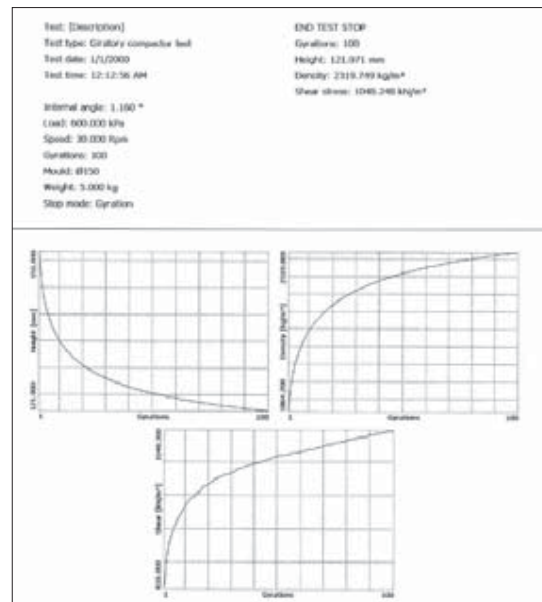

Final report

...follows...

MATEST

B041-28

GAM - Gyrotory internal Angle Measurer

STANDARDS: EN 12697-31 / ASTM D7115 / AASHTOT344

This Gyrotory Angle Measurer has been designed by MATEST to provide an angle validating device which can be used by the operator to carry on the calibration of the Gyrotory Compactor.

The device perfectly simulates a HMA specimen as it generates an equivalent tilting moment and shear forces.

GAM can cover a wide range of angles, including the ones specified by EN and ASTM Standards.

The device allows to perform TOP and BOTTOM angle measurements as specified by the Standards; the average of the obtained values is then considered as the "internal angle of the machine".

An excel spreadsheet, which is supplied along with the device, is used for data acquisition and processing, and provides the precise value of the internal angle according to the calculation procedure specified by EN 12697-31 (Annex-C) and AASHTO T344.

The spreadsheet allows to plot several graphs showing the measured data and it also provides some important indexes about the quality of the data.

NEW

section B



92

MAIN FEATURES:

- High accuracy of the measured data
- The device is supplied complete with:
 - Two different rings to perform tests either with M=240Nm or M=425Nm
 - Upper and lower base plate
 - RS232 cable
 - Strong practical suitcase
 - Calibration certificate
- Data are read by GAM and then downloaded (via RS232 cable) all together at the end of the measurements, with no need to connect the device to the PC after each measurement
- Possibility to repeat even just one of the measurement, and lately include it in the calculation spreadsheet
- Data processing is carried out by a specific spreadsheet, which also allows to create the final calibration certificate
- No need for power supply since the device is battery operated. Also it has an energy saving feature which automatically switch off the device if it is not being used for a while.

TECHNICAL DETAILS:

- Connection to PC through RS232 cable
- Three modes of data acquisition: Single, Partial or Complete
- Accuracy: more than 0.01°, as requested by the Standards

Power supply: n°2 batteries 1.5V type AA

Dimensions: Diameter 150mm, Height 115mm

Weight: 5.6 kg

ACCESSORIES:

B041-50 GAM CALIBRATION-CHECKING set to ASTM (1.16° angle). The set is composed by two square rules. Supplied complete with factory certificate.

B041-51 GAM CALIBRATION-CHECKING set to EN (0.82° angle). The set is composed by two square rules. Supplied complete with factory certificate.

B041-55 ACCREDIA Official Calibration Certificate of the angle, for the square rules (ASTM and EN).



B041-50

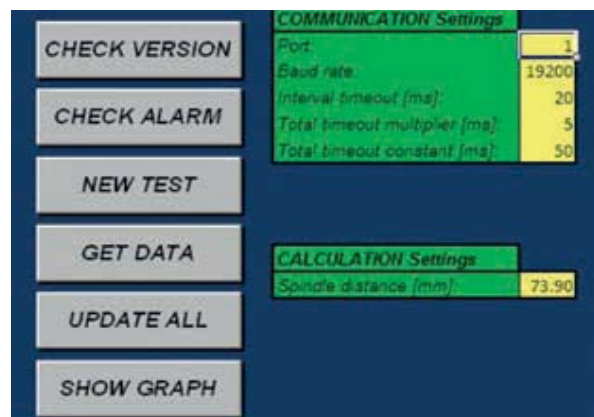
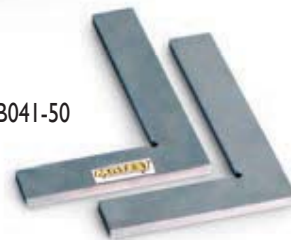

Excel spreadsheet: it allows several operation to be carried on (data acquisition, data processing, visualization of graphs,...)

ARC

ASPHALT ROLLER COMPACTOR

meets and exceeds EN 12697-33

THE FIRST ELECTROMECHANICAL SYSTEM FOR THE BEST SPECIMEN DENSITY



HIGH
LOAD

HOT
ROLL

MULTI
SIZE

HEATED
CART

PERFECT
SLAB
FLATNESS

THERMAL
SHOCK
PREVENTION

B039

ARC - Asphalt Roller Compactor

TECHNICAL SPECIFICATIONS:

- Possibility to use **standard or heated segment rollers of different sizes** (see accessories): width up to 400 mm, length up to 500 mm and radius 490 mm, to obtain slabs of
 - 320x260 mm, thick up to 180 mm
 - 305x305x25 to 100 mm thick
 - 400x305x25 to 100 mm thick
 - 500x400 mm, thick up to 180mm
- Vertical force selectable up to max. 40 kN
- **Programmable density target compaction**
- Polycarbonate safety guard as requested by CE Directive
- Possibility to **perform the two-phase procedure (Pre-compaction and Compaction)** as specified by TP Asphalt-StB 33 or even just **one of them** **NEW**
- The required n° of passes can be set before starting the test allowing an accurate test control by n° of passes **NEW**
- **Sliding carriage speed adjustable** between 3 m/min and 12 m/min **NEW**
- **Detailed output file** listing each pass and displaying duration, sample height, applied load and eventual roller and cart temperature **NEW**



B039
with open guard

...follows...



B039

**ARC - Asphalt Roller Compactor, Electromechanical system
High load, hot roll, multi size**

STANDARD: EN 12697-33

Asphalt Roller Compactor is entirely developed and manufactured by Matest. The machine works with an **electromechanical system, and therefore it does not require any air source (compressor) or hydraulic pressure.**

It is used to produce representative sample slabs of several dimensions of bituminous mixtures laid and compacted on site.

The compaction is performed through a segmented roller with alternated operated rotation which simulates the on-site action of a street roller. The compaction cycle can be programmed in accordance to a certain load or deformation value.

The flexibility of the program grants the production of samples with uniform density and dimensions, fully meeting Standards specifications and research requirements; these samples are compatible for rut test with Matest Wheel Tracking apparatus B038 (see page 98).

The sample slabs can be also cored or cut off to obtain cylinders and beams for bending fatigue, indirect tensile, static and dynamic creep, stiffness, and 4-point tests.



section B



94



B039

MAIN FEATURES:

- Sturdy frame made of steel
- Mould supporting table with alternating displacement system, for table displacement and vertical load pressure
- Integrated touch screen control unit based on **Windows operating system**. The control unit runs like a standard PC for the management and analysis of data, test results, graphs.
- The **touch-screen icon interface** allows an easy set up of the parameters and an immediate execution of the test.
- **Direct Internet and Intranet (LAN) connection for remote technical assistance**. This features allows operators to establish a remote communication and receive software updates or an immediate diagnostic analysis of the potential problem from Matest technicians. Hardware technical details: see pag. 24
- **Unlimited memory storage** with: 2 USB ports, 1 SD card slot.
- **Heating of the segment roller** (optional)
- Simple and quick roller and mould positioning
- **Perfect horizontal flatness of the slab surface**
- **Uniform density and dimensions of the slabs**
- Easy to maintain



Detail of the control panel

MATEST

Three transducers are installed to manage the roller and table displacements and vertical load pressure.

The compaction cycle can be programmed up to a certain load or deformation value. When deformation value is programmed, the system automatically programs the suitable loads to obtain the selected final thickness.

The flexibility of the program grants the production of samples with uniform density and dimensions, fully meeting Standards Spec. and Research requirements.

A friendly and easy to use interface allows an immediate and fully automatic test execution, data acquisition and processing, test report and file.

The Roller Compactor is supplied "without" roller segment, slab mould, centering plate, that must be ordered separately (see accessories).

Power supply: 230V 50/60Hz 1ph 2100W (3100W with the heated segment roller)

Dimensions: 2200x1030 xh 1880 mm (2410mm with opened guard)

Weight: 1300 kg

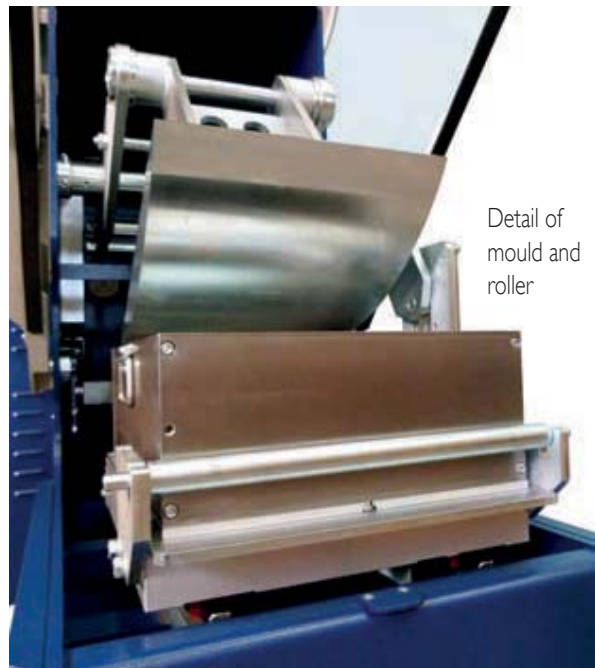

Detail of mould and roller

section B



ACCESSORIES:

"STANDARD" SEGMENT ROLLER, available dimensions:

B039-04 ROLLER for 320x260mm mould

B039-05 ROLLER for 500x400mm mould

B039-06 ROLLER for 400x305mm mould

B039-07 ROLLER for 305x305mm mould

MOULD to prepare asphalt slabs. Complete with handles. Available dimensions:

B038-09 MOULD for slabs 320x260x180mm

B038-10 MOULD for slabs 305x305x50mm

B038-11 MOULD for slabs 305x305x100mm

B038-12 MOULD for slabs 400x305x50mm (no handles)

B038-13 MOULD for slabs 400x305x100mm

B038-18 MOULD for slabs 500x400x180mm

B038-19 MOULD for slabs 400x305x120mm

B038-20 MOULD for slabs 320x260x50mm

B039-21 Centering Plate for 400x305mm mould

B039-22 Centering Plate for 305x305mm mould

B039-23 Centering Plate for 320x260mm mould

B039-15 ROLLING VIBRATING DEVICE, reproducing street-roller vibrations during asphalt laying off.



Heating of Segment Roller and Sliding Cart

Possibility to heat and control temperature of the Segment Roller mounted on the Compactor and Sliding Carriage to keep the mould warm and avoid thermal shocks the might affect specimen's workability

The equipment is composed by:

B039-02 Control Unit

Mounted in the Roller Compactor, it foresees a thermoregulator circuit, complete with probe to measure and to adjust the temperature from room up to 180°C.

It is connected to the segment roller equipped with heating resistances.

"HEATED" SEGMENT ROLLER, complete with heating resistances. Available dimensions:

B039-04R ROLLER for 320x260mm mould

B039-05R ROLLER for 500x400mm mould

B039-06R ROLLER for 400x305mm mould

B039-07R ROLLER for 305x305mm mould



B039-03 Sliding Cart Heating Option

Thermoregulated circuit with temperature probe to set and control cart temperature and keep mould hot

MATEST

B039A

ASC - Asphalt Shear box Compactor

Asphalt technologists are acutely aware of the importance of a representative specimen during any laboratory performance testing. The precise shearing motion of the ASC replicates the conditions of field compaction in order to reproduce the field properties of asphalt, quickly and easily under the controlled conditions of a laboratory.

The ASC compacts large asphalt prisms that can be sawn to produce four to six beams or slabs for laboratory wheel tracking; or the prism can be cored to produce three to four 100mm diameter cylinders, all having essentially identical properties.

The electronic control unit with touch screen color display operates like a standard Windows based PC for the management and analysis of the data, test results and graphs.

The user friendly touch-screen icon interface allows for easy set up parameter entry, enables immediate (fully automatic test execution) data acquisition/processing, test report, and data file generation.

A LAN connection to Intranet/Internet enables remote communication to receive immediate diagnostic analysis and technical support from Matest technicians, and/or software updates.

section B



B039A

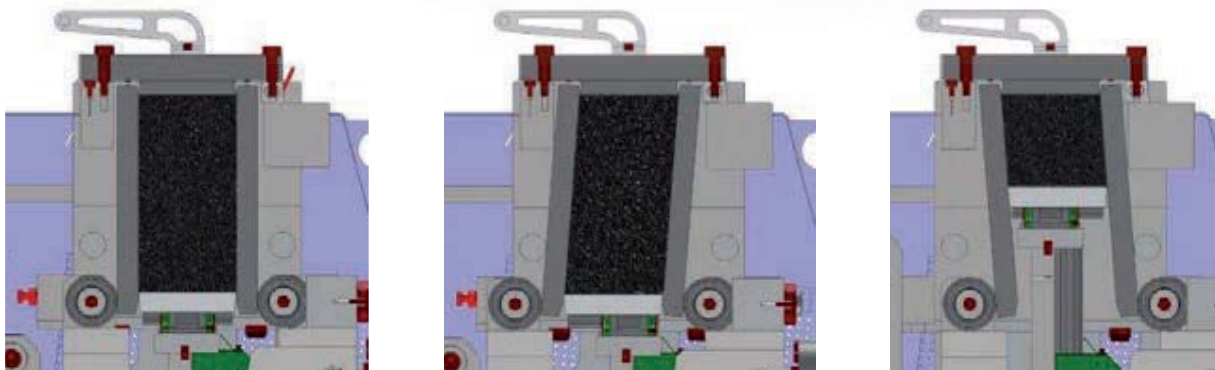

During the compaction process a lateral displacement is applied to the specimen along with a vertical load, which results in a shearing action that makes the compaction similar to the the on-field one.

MAIN FEATURES:

- Extremely sturdy fabricated frame combined with precision machined components
- Servo hydraulic vertical ram with integral hydraulic power supply
- Precision electro-mechanical shearing motion
- Integral specimen extruder
- Electronic control unit with touch screen color display (no need for PC)
- Unlimited memory storage with: 2 USB ports, 1 SD card slot, RS232/485 serial port
- The compaction cycle can be programmed by specifying vertical stress/load and test termination conditions; Number of cycles, Specimen height and/or density
- ASC can be equipped with a load cell for shear stress measurement, upon request

TECHNICAL SPECIFICATION:

| | |
|----------------------------------|---|
| Vertical force: | Up to 100kN |
| Shearing force: | Up to 50kN |
| Shear angle: | $4^{\circ} \pm 0.1^{\circ}$ |
| Shearing cycle rate: | 3 ± 0.1 gyrations per minute |
| Mould width: | $150\text{mm} \pm 0.1\text{mm}$ |
| Mould length: | $450\text{mm} \pm 0.1\text{mm}$ |
| Mould surface finish (inside): | Smoother than $0.4\mu\text{m rms}$ |
| Mould surface hardness: | More than 48 Rockwell C |
| Mould capacity: | Approx. 20 litres |
| Loading platen width: | $149\text{mm} \pm 0.2\text{mm}$ |
| Loading platen length: | $449\text{mm} \pm 0.2\text{mm}$ |
| Loading platen smoothness: | Smoother than $0.4\mu\text{m rms}$ |
| Loading platen surface hardness: | More than 48 Rockwell C |
| Number of cycles: | Up to 100 |
| Vertical stress: | 0.1 to $1.5\text{MPa} \pm 0.01\text{MPa}$ |
| Compaction height: | 145mm to $185\text{mm} \pm 0.1\text{mm}$ |
| Power supply: | 230V 1ph 50/60Hz |
| Dimensions: | $788 \times 1360 \times (\text{H}) 1314\text{mm}$ |
| Weight: | 1200 kg |

ACCESSORIES:

- B039A-01** Loading Chute
- B039A-02** Tray (2 off)
- B039A-03** Spreading comb
- B039A-04** Leveling blade



Specimen is extruded after the machine has completed the specified number of cycles, or when the required specimen height has been reached.

An automatic extruder allows an easy extraction of the compacted specimen.



Test parameters during compaction

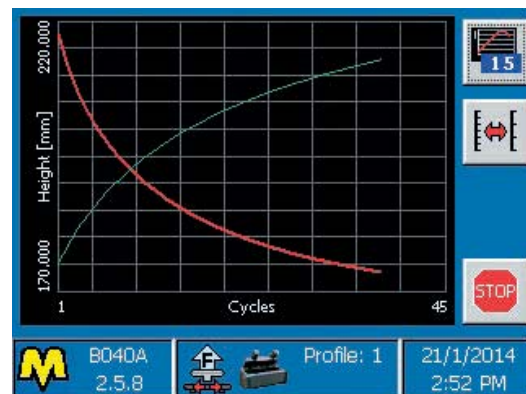

Height-Cycles and Density-Cycles curves during compaction



B038

UNITRACKER - Single Wheel Tracking Apparatus

STANDARDS: EN 12697-22 / BS 598:110

This test, developed in laboratory, consists in evaluating the deformation (rut) depth of a bituminous mixture subjected to cycles of passes of a loaded rubber wheel under constant and controlled temperature conditions.

To perform the test, a wheel tracking apparatus is used to simulate the effect of traffic and to measure the deformation susceptibility of the bituminous sample.

Matest wheel tracker performs the test as per procedures A and B (6 or 2 tests), clearly specified by the EN Standard.

section B



98

Technical specifications

- The machine fully satisfies both EN 12697-22 and BS 598:110 Specifications.

- Travel of the table: 230 +/- 5 mm

- Table cycle frequency: adjustable 15 to 40 cycles per minute.

- Hard rubber tyred wheel having outside diameter 200 mm

- Wheel load on the sample:
700N +/- 10N (EN 12697-22)
or 520N (BS 598:110)

The load is applied on the sample through a lever;

The effective load applied on the sample can be adjusted by micrometrical weights positioning.

- Continuous real time rut depth measurement (penetration of the wheel into the sample) through a linear transducer 40 mm travel by 0,01 mm accuracy.

- The test frame is made of robust aluminium alloy and it is contained in a climatic cabinet with adjustable temperature from 30 to 65°C, +/- 1.0°C

The cabinet is equipped with two doors with insulated glass for inspection

- The sample table has dimensions: 400 x 390 mm and can accept rectangular slabs of several sizes:

305 x 305 mm, 50 or 100 mm high

305 x 400 mm, 50 or 100 mm high

200 mm dia. core samples, 50 mm high

The sample confinement frames are not included and have to be ordered separately (see accessories)

- Matest wheel tracker accepts also samples with dimensions up to 400 x 500 mm, 180 mm high (this mould can be compacted with Matest Roller Compactor)

- The machine is supplied complete with adaptors for a correct mould positioning and locking

- The wheel tracker is equipped with 3 temperature probes:
1 probe, connected to the thermoregulator, for the control and adjustment of the cabinet temperature.

2 probes for temperature measurement inside the specimen.



B038 with open doors

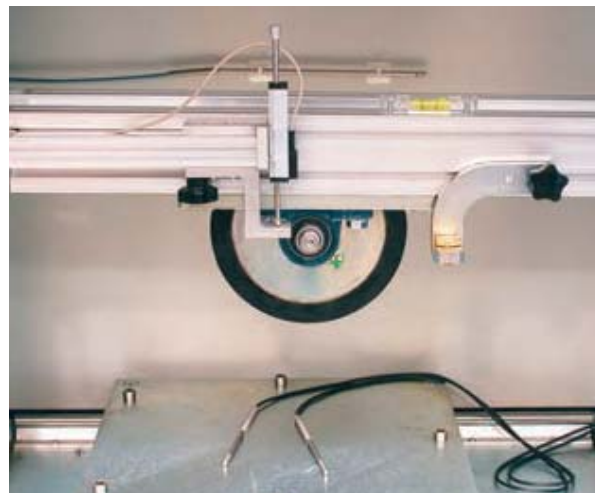

B038 detail

Hardware

- Data acquisition and processing system fully managed by micro-processor.
- Multifunctions keyboard with encoder for easy and rapid setup
- Large graphic display 320x240 pixel.
- RS 232 port for connection to PC.

Firmware

The multilingual testing firmware allows:

- Management and automatic control of machine and test.
- Setup of all test parameters.
- Test data acquisition and processing
- Real time display of: number of cycles, rut depth, temperatures. Real time cycle rate will also be displayed when using a serial connection to PC
- Calibration menu for setting and checking all test data.
- From the control board, it is possible to select parameters, set data acquisition and processing according to EN and BS test procedures, with:
 - Identification data of the sample (slab) under test.
 - Cycle frequency.
 - Number of passes to end the test.
 - Max rut depth to end the test.
 - Sampling frequency of the rut depth.
 - Testing temperature.
 - Sample (slab) thickness.



B038 detail

The use of the B038 Wheel Tracker requires connection to a PC with Windows 98, 2000, XP minimum requirements.

Power supply: 230V 50/60Hz 1 ph 2200W

Power rating of the table: 500 W

Dimensions: 1580 x 650 x 1790 mm

Weight: 400 kg approx.



B038 with closed doors

ACCESSORIES:

- * **B038-09** MOULD with HANDLES size 320 x 260 x 180 mm
- * **B038-10** MOULD with HANDLES size 305 x 305 x 50 mm
- * **B038-11** MOULD with HANDLES size 305 x 305 x 100 mm
- * **B038-12** MOULD no HANDLES size 400 x 305 x 50 mm
- * **B038-13** MOULD with HANDLES size 400 x 305 x 100 mm
- B038-14** MOULD for core sample 200 mm diameter, 50 mm high
- * **B038-18** MOULD with HANDLES size 500 x 400 x 180 mm
- * **B038-19** MOULD with HANDLES size 400 x 305 x 120 mm
- * **B038-20** MOULD with HANDLES size 320 x 260 x 50 mm
- H009-01** PC complete with LCD monitor 22", keyboard, mouse, cables, installation.

Notes:

- * These moulds are suitable to be used also with Matest Roller Compactor.
- Insert plates to reduce the thickness of the mould are available on request.



B038A

SMARTRACKER™

MULTI WHEELS HAMBURG WHEEL TRACKER; TEST ENVIRONMENT: DRY+WET
STANDARDS: EN 12697-22 / AASHTO T-324

The Hamburg wheel tracking device can be used to determine the resistance of Hot Mix Asphalt (HMA) to rutting and moisture sensitivity. Matest model "SmarTracker™" meets and exceeds EN and AASHTO.

It is intelligently designed with innovative features and the needs of the end users in mind.

The most versatile wheel tracker on the market has independent motors for each wheel which assure separate rutting analysis of each specimen.

Now you can perform wet or dry test with both wheels or run one wheel under dry and one wheel under wet condition simultaneously during a single test.

Determine the creep slope, stripping inflection point and stripping slope with this state of the art and user friendly machine.

MATEST SmarTracker™ has been developed by our R&D engineers and scientific in association with some of the most experienced and reputable industry experts in the USA and the world.



section B



100



B038A

SMART FEATURES:

- Comply with EN 12697-22 and AASHTO T324.
- **No lifting of heavy wheel assemblies.** Wheels retract automatically away from samples and park into rest position.
- **Sturdy machine,** designed for the rugged construction laboratory environment stainless steel sample tanks.
- **Two independent loaded wheel systems each capable of conducting wet or dry sample tests simultaneously.**
- **Sliding sample positioning mechanism** for easy mould handling and placement in the machine.
- Does not require lifting of heavy wheel components.
- **Fully Automatic machine.** Detects and stops the test when the target rut depth is reached.
- **Touch-screen control unit based on Windows operating system** for user friendly execution of the test, management of the data and visualization of the results.
- Each of the two wheel assemblies is equipped with displacement transducers for rut measurement.
- Mechanical recirculating water bath for temperature control within ± 1 °C.
- **Easy to load, unload, drain water and clean the unit after each test.**
- Small footprint to accommodate small construction labs.

MATEST

SmarTracker™

ITS INTELLIGENT DESIGN IS JUST THE BEGINNING



section B



101

SIMULTANEOUS TESTING OF WET AND DRY SAMPLES

WHEELS INNOVATIVE ROLL OFF MECHANISM

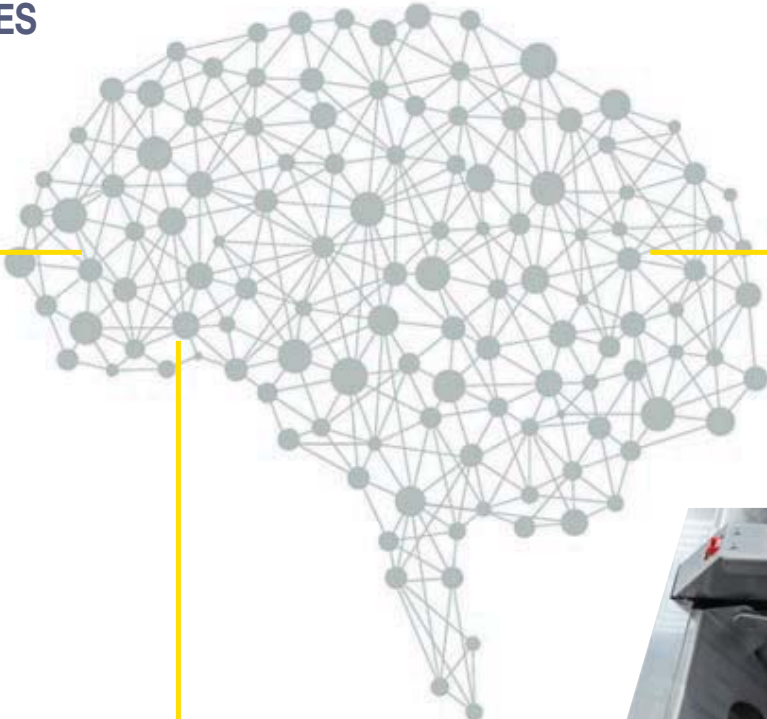

UNIQUE SYSTEM TO LOAD-UNLOAD THE MOULD

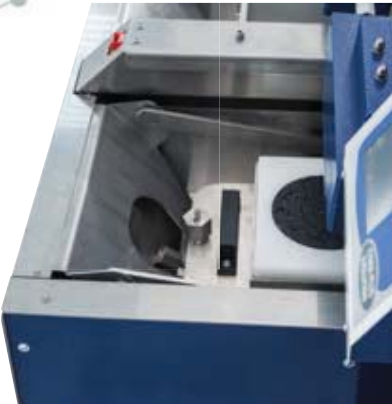

MATEST

...follows...

material testing equipment

B038A

The **SMARTRACKER™** combines smart features with the solid construction needed for the rugged laboratory environment.

TOP FEATURES:

- Meets and exceeds AASHTO and EN Standards
- Simultaneous testing of wet and dry samples
- Independent motors for each wheel assure separate rutting analysis of each specimen
- High performance components
- Rugged machine with ample use of stainless steel

SAFETY FEATURES:

- No added stress to operators back from lifting heavy wheel assemblies
- Sample holders slide into position and eliminate demanding lifting and placement of samples into the unit
- Hood keeps technicians away from moving parts and provides better temperature control while the test is being conducted



B038A open

TESTING SOFTWARE

The user-friendly software is integrated into the on-board digital control unit based on Windows operating system. The software is fully customizable by the operator according to EN and AASHTO Standards, and the personal needs. Automatic calculation of stripping inflection point (AASHTO). Test execution and all parameters, such as water/air temperature, specimen temperature, rut depth... can be monitored in real time. The software also allows exporting test data to an Excel compatible format.



Real time results plot of the Rut Depth along with the no. of passes.

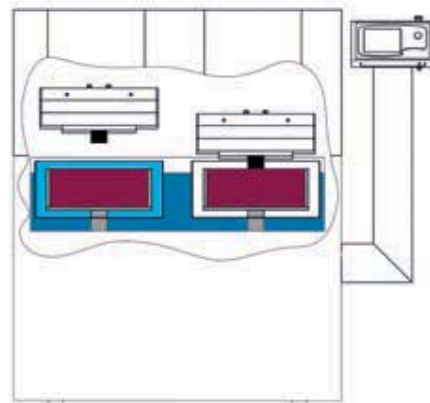

Smartracker while performing a dry test (right tank) + wet test (left tank) at the same time.



TECHNICAL DETAILS:

- Wheel load: 705 N
- Wheel speed: from 20 to 30 cycles/minute.
- Temperature control:
EN 12697-22: 2500 W heaters for air temperature control, ventilation for temperature uniformity, probe for air temperature, all controlled by the electronic system.
AASHTO T324: 4000 W heaters, recirculating pump, automatic feed and controls level.
- Temperature control range: from ambient up to $75^{\circ} \pm 1^{\circ} \text{C}$
- Table travel: 230 mm
- Rut depth transducers range: $25 \text{ mm} \pm 0,1 \text{ mm}$ accuracy.
- Slab thickness: adjustable from 38 to 120 mm

Power supply: 220V 50 Hz - 110V 60 Hz

Dimensions: 1400x1300x1300 mm

Weight: 450 kg



B038A-01

Rubber wheel for EN 12697-22

B038A-02

Steel wheel for AASHTO T324

NEEDED ACCESSORIES:

EN 12697-22

- **B038A-01** Rubber wheel 203x50 mm
- **B038A-11** EN Mould 400x305xH120 mm
- **B038A-12** Set of vertical adaptors for EN mould to allow the positioning of specimens lower than 120 mm (up to a minimum specimen thickness of 20 mm)
- **B038A-13** Set of horizontal adaptors for EN mould to allow the positioning of specimens 260x230 mm and 305x305mm

AASHTO T324

- **B038A-02** Steel wheel 203x47 mm
- **B038A-10** AASHTO Mould (2 cylinders dia. 150x60 mm)
- **B038A-03** Tool for AASHTO positioning



B038A-10 AASHTO mould

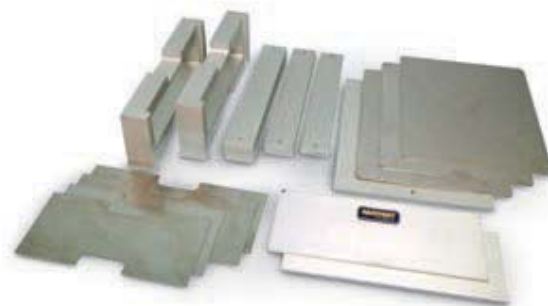
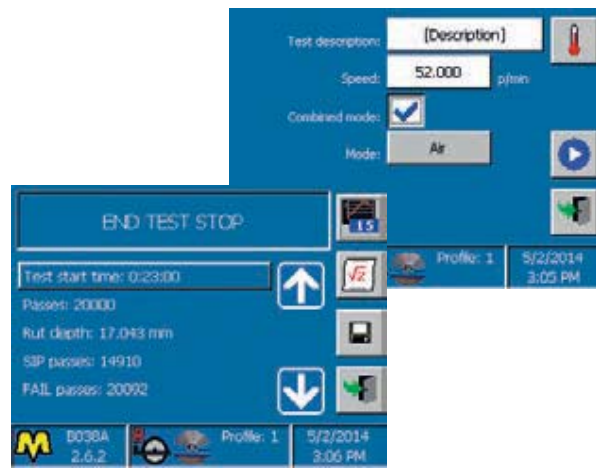

B038A-13

Horizontal adaptors for EN moulds

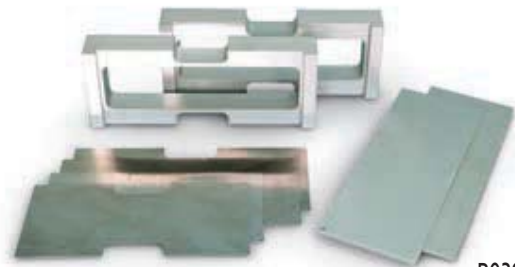

B038A-12

Vertical adaptors for EN moulds



B038A-11 EN mould

OPTIONAL ACCESSORIES:

- **B038A-04** Electrovalve group for hot water
- **B038A-05** Air heating system for air conditioning test EN 12697-22
- **B038A-06** Probe for specimen's temperature determination
- **B038A-14** Verification KIT for the calibration of the wheel load



Pavetest, a new division of Matest

Pavetest is the new division of Matest committed to developing innovative, dynamic testing systems for asphalt.

Whilst Pavetest Pty. Ltd. may be a new player in this growing market sector, they are certainly not lacking experience. With many years of experience in developing pavement testing systems between them, Con Sinadinos (Managing Director) and Alan Feeley (Technical Director) bring a wealth of experience and talent to the company. The benefit is evident in every aspect of every product, which are designed to perform, built to last and easy to use.

From its inception, Pavetest's aim is to develop a range of **testing systems with unparalleled performance, ultimate versatility and exceptional reliability, at a price that represents real value for money.**

Pavetest's range of pavement testing systems both complements and completes Matest's Asphalt and Bitumen business unit.

section B

CDAS - Control and Data Acquisition System

Pavetest's compact Control and Data Acquisition System (CDAS) delivers unparalleled performance, real time control and ultimate versatility in acquisition.

The CDAS:

- provides excellent waveform fidelity from integrated acquisition and control functions, with low level sampling at speeds of up to 192,000 samples per second simultaneously on all channels (using up to 64x oversampling)
- gives superior low noise performance and resolution of 20 bit over the full dynamic input signal range (no auto ranging required).



B206 CDAS 16 channels

AVAILABLE MODELS:

B205 8 Channel CDAS - Acquisition 8 CH, 20 bit resolution
 Sampling rate up to 192 kHz (all channels)
 Smoothing up to 64 times over-sampling
 Calibration on power up
 Control Axis 2
 Communication USB or Ethernet

B206 16 Channel CDAS - Acquisition 16 CH, 20 bit resolution
 Sampling rate up to 192 kHz (all channels)
 Smoothing up to 64 times over-sampling
 Calibration Automatically on power up
 Control Axis 4
 Communication USB or Ethernet

Dimensions: 100(h) x 310(d) x 250(w) mm
 Power Supply: 90-264V 50/60 Hz 1ph 240 W

TestLab Software

Developed with ultimate flexibility in mind, TestLab test and control software caters to all levels of operator experience. By using pre-programmed "Method files", an inexperienced operator can run a range of international test methods without the need for any programming. Moreover, a test "Wizard", available with popular tests, can guide the operator step by step based on a "recipe book" approach. Most importantly, the experienced engineer and/or researcher need not be constrained by the functions and analysis in the method files provided. The operator may clone, modify and/or generate his/her own method file to suit their specific requirements. The Excel based data analysis offers the operator the flexibility to implement alternative analysis and customize reporting facilities.

TestLab allows for real time graphing of results and configurable real time transducer levels display with unprecedented clarity of results and analytical power.

TestLab software is included with CDAS - Control and Data Acquisition System. It is supplied on CD that also includes the relevant Method files (based on the test configurations supplied) and calibration files for all transducers supplied.



B200

AMPT/SPT Asphalt Mixture Performance Tester

The Pavetest AMPT is a servo-hydraulically controlled testing machine specifically designed to perform the three asphalt tests developed under NCHRP Projects 9-19 and 9-29; Dynamic Modulus, Flow Number and Flow Time.

It is also the prescribed equipment in AASHTO TP 79-09 Standard Method Test for Determining the Dynamic Modulus and Flow Number for Hot Mix Asphalt (HMA) using the Asphalt Mixture Performance Tester (AMPT).

In addition, the Pavetest AMPT can also perform Direct Tension Cyclic Fatigue, Indirect Tensile Dynamic Modulus, Incremental Repeated Load Permanent Deformation, Semi-circular bend, and Overlay Testing of Asphalt Mixtures.

The Pavetest AMPT is underpinned by Pavetest's leading edge CDAS digital controller, TestLab software and a full complement of accessories, hardware and software in perfect unison.

The machine includes:

- 8 Channel Control and Data Acquisition System (CDAS) & TestLab software (see page 104)
- 30 mm Actuator LVDT
- Load cell (± 15 kN)
- Pressure transducer (± 300 kPa)
- Temperature transducer (from 0°C to +65°C)
- On-specimen LVDT (2 mm) (3 pieces)
- 105 mm bottom loading platen
- 105 mm top loading platen

MAIN FEATURES:

- **Compact, fully self contained, precision engineered unit.**
- Thermoelectric (TE) Heating/Cooling - More reliable and environmentally friendly than mechanical refrigeration & heating elements.
- **Built-in, silent, air compressor with associated air preparation equipment** – No need for external compressed air supply.
- **Patented magnetically mounted on-specimen transducer system**, based on loose core LVDTs.
- Optional Epsilon (extensometer) on-specimen strain transducers.
- **Gauge point fixing jig** facilitates gluing gauge points and the (top and bottom) platens for proposed AMPT Direct Tension Cyclic Fatigue (S-VECD) Test.
- **Dynamic Verification Device.**

TECHNICAL SPECIFICATIONS:

- Load capacity: 15 kN (Static) - 13.5 kN (Dynamic)
- Actuator stroke: 30 mm
- Specimen size: 100 mm (dia) x 150 mm (h)
- Temperature range: 4 to 60°C
- Confining pressure: 0 to 210 kPa
- Noise level: Less than 70 db at 2 m

Power Supply: 230 V 50 Hz 1ph 3,2 kW

Dimensions: 1510(h) x 650(d) x 1220(w) mm

Weight: 300 kg (excluding oil)



B202
Gauge point fixing jig



B203 verification device with on-specimen LVDTs and load cell

B200 AMPT/SPT Asphalt Mixture Performance Tester



CONSUMABLE ACCESSORIES:

B201 KIT AMPT Consumables kit. Comprises:

- **B201-51** Gauge point (24 pieces)
- **B201-52** 5 Minute, two part epoxy 24 mL
- **S311-03** 100 mm Sealing Rings (Pack of 10)
- **S310-03** 100 mm Rubber membranes (Pack of 10)

RECOMMENDED ACCESSORIES:

- B202** AMPT Gauge Point Fixing Jig
- B203** AMPT Dynamic Verification Device
- H009-01** PC complete with LCD monitor 22", keyboard, mouse, cables and installation of Testlab software

TESTING JIGS:

B204 KIT AMPT Overlay kit. Comprises:

- **B204-01** AMPT Overlay jig
- **B204-02** Pair of Overlay Tester (OT) specimen plates
- **B204-03** OT specimen preparation kit

B207 KIT AMPT Indirect Tensile (IDT) kit. Comprises:

- **B207-01** AMPT IDT jig
- **B253-01** AASHTO T322 LVDT mounting kit
- **B253-03** AASHTO T322 gauge point template (150 mm specimen)
- **B290-08** AMPT Miniature LVDT (1 mm) (4 pieces)
- **B253-51** AASHTO T322 short gauge point (16 pieces)
- **B253-52** AASHTO T322 long gauge point (16 pieces)

B208 AMPT Semi-Circular Bending (SCB) Jig



B210 KIT STAND-ALONE SERVO-PNEUMATIC FOUR POINT BENDING (4PB) SYSTEM

STANDARDS: EN 12697-24 Annex D / EN 12697-26 Annex B / AASHTO T321 / ASTM 03 / ASTM-D7460

The Pavetest Servo-pneumatic Four Point Bending (4PB) System is a servo-pneumatic testing machine utilizing digital control of a high performance servo valve to provide accurate loading wave shapes up to 60Hz. The 4PB system can be operated in haversine or sinusoidal, controlled strain or sinusoidal controlled stress mode to determine the flexural stiffness/modulus and resistance to fatigue of asphalt beams of various sizes.

The 4PB System is underpinned by Pavetest's leading edge CDAS digital controller, TestLab software and a full complement of accessories, hardware and software in perfect unison.

B210 KIT comprises:

- **B210-01** Servo-pneumatic Four Point Bending (4PB) Device with 10 mm actuator LVDT, ± 5 kN load cell, and 2 mm On-specimen LVDT
- **B205** 8 Channel Control and Data Acquisition System (CDAS) & TestLab software (see page 104)
- **B270-12** Air reservoir assembly

Requires pressurized air; minimum 7 bar (not included).

MAIN FEATURES:

- Robust four point loading frame
- Backlash free rotation and translation on all load and reaction points
- Fully configurable to suit a large range of testing applications
- High performance servo-valve
- Long life pneumatic actuator
- Digital Servo-pneumatic control
- 2 axis control and 8 channel data acquisition

TECHNICAL SPECIFICATIONS:

- **Load frame** Outer clamp span 355.5 mm (14") and 420 mm
Nominal beam size(s): 50 mm (h) X 50 mm (w)
50 mm (h) X 63.5 mm (w)
70 mm (h) X 70 mm (w)
- **Servo actuator** Capacity ± 5 kN; Frequency Up to 60 Hz;
Stroke 10 mm
- **On-specimen transducer** Range ± 1 mm; Resolution 0.0002 μ m;
Accuracy Better than 5 μ m

Power Supply: 90-264V 50/60 Hz 1ph 300 W (B210 KIT)

Dimensions: 600(h) x 250(d) x 570(w) mm (B210-01)

420(h) x 250(d) x 570(w) mm (B212)

Weight: 39 kg

4PBA on DTS16:

B210-01 Servo-pneumatic Four Point Bending (4PB) device with 10 mm actuator LVDT, ± 5 kN load cell and 2 mm Onspecimen LVDT

4PBA on DTS30:

B212 4PB JIG (see page 110).

RECOMMENDED ACCESSORIES:

B221 Temperature controlled cabinet: -20°C to +80°C to suit DTS-16 or 4PBA

H009-01 PC complete with LCD monitor 22", keyboard, mouse, cables and installation of Testlab software



B210-01

Servo-pneumatic four point apparatus

ACCESSORIES:

B210-02 4PB PVC Beam

B210-03 4PB Reference beam

B250-07 KIT Temperature measuring kit comprising:

- **B292-01** Temperature transducer (-80°C to +80°C) (2 pieces)
- **B250-10** Dummy asphalt specimen
- **B250-11** 100 mm "O" ring (3 pieces)
- **B250-12** Thermal conducting grease (about 56 g)

TECHNICAL FEATURES:

- The specimen is securely clamped using servo-motor driven ball screws to maintain the prescribed clamping force and accommodate any compliance of the specimen between the clamping surfaces, during the test. The clamping force is controlled by regulating the motor current.
- Two switches, located on the front of the device, are used to activate and release the inner and outer specimen clamps. The four specimen yokes provide backlash free rotation and translation at all load and reaction points.
- Markings on the top clamp pads assist the operator to centre the beam laterally prior to clamping.
- The servo-pneumatic system uses a bottom loading pneumatic actuator coupled to a high performance servo valve, with PID closed-loop control and run time adaptive control to achieve/maintain the requested strain/stress for the duration of the test.
- A low profile, high performance stainless steel ring torsion load cell is used to measure and control the load and a co-axially mounted (LVDT) displacement transducer on the actuator is used to position the centre cradle.
- An on-specimen (LVDT) displacement transducer is used to measure and control the deflection at the centre of the beam with respect to the outer load/reaction points, as prescribed in the relevant standards.
- The Windows based, TestLab software provides a user interface that is as simple and efficient as possible and application software according to the above mentioned international Standards.



16 kN SERVO-PNEUMATIC DYNAMIC TESTING SYSTEM - two models available:

B220-01 KIT DTS-16 with manual crosshead

B220-02 KIT DTS-16 with motorized crosshead

The DTS-16 Dynamic Testing System is a servo-pneumatically controlled testing machine utilizing digital control of a pneumatic servo valve to provide accurate loading wave shapes up to 70 Hz. The DTS-16 can be operated in tension, compression dynamic loading and is suited to testing a diverse range of materials such as asphalt, soil, unbound granular materials, fibres and plastics.

The DTS-16 is underpinned by Pavetest's leading edge CDAS digital controller, TestLab software and a full complement of accessories, hardware and software in perfect unison.

The machines comprise:

B220-11 20 kN Load frame with manual crosshead,
16 kN Servo-pneumatic actuator with its LVDT (30 mm stroke),
± 20 kN load cell

or

B220-12 20 kN Load frame with motorized crosshead,
16 kN Servo-pneumatic actuator with its LVDT (30 mm stroke),
± 20 kN load cell

B206 16 Channel Control and Data Acquisition System
(CDAS) & TestLab software (see page 104)

B270-12 Air reservoir assembly

Requires pressurized air, minimum 7 bar (not included).

| Model | B220-01 KIT | B220-02 KIT |
|----------------|-------------|-------------|
| B220-11 | ● | |
| B220-12 | | ● |
| B206 | ● | ● |
| B270-12 | ● | ● |

MAIN FEATURES:

- Compact, robust 2-Column load frame
- Precision engineered
- Optional Motorized crosshead positioning
- Fully configurable to suit a large range of testing applications
- Digital Servo-Pneumatic control
- 4 axis control and 16 Channel Control and Data Acquisition System

TECHNICAL SPECIFICATIONS:

- **Load frame** Between Columns 345 mm
Vertical Space 650 mm
- **Servo actuator** Capacity ±16 kN
Frequency up to 70 Hz
Stroke 30 mm
Air supply clean dry air
Pressure 800-900 kPa
Minimum rate 5 litres/sec

Power Supply: 230V 50 Hz 1 ph 100 W (B220-12)
230V 50 Hz 1 ph 1450 W (B221)

Dimensions: 1020(h) x 450(d) x 500(w) mm load frame
2100(h) x 900(d) x 750(w) mm with temperature controlled cabinet

Weight: 100 kg without temperature controlled cabinet

TEST CONFIGURATIONS and RELATED JIGS:

consult the following pages



B220-02 KIT 16 kN Servo-Pneumatic dynamic testing system (motorized crosshead) with **B221** Temperature controlled cabinet

RECOMMENDED ACCESSORIES:

B221 Temperature controlled cabinet: -20°C to +80°C to suit DTS-16 or 4PBA

B250-07 KIT Temperature measuring kit (see page 106)

H009-01 PC complete with LCD monitor 22", keyboard, mouse, cables and installation of Testlab software

We can upgrade your existing UTM (also from other manufacturers)



B220-02 KIT
DTS-16 detail



B220-12
20 kN Load frame with motorized crosshead

section B



107



B230

30 kN SERVO-HYDRAULIC DYNAMIC TESTING SYSTEM (DTS-30)

The DTS-30 Dynamic Testing System is a servo-hydraulic testing machine utilizing digital control of a high performance servo valve to provide accurate loading wave shapes up to 100 Hz. The DTS-30 can be operated in tension, compression dynamic loading and is suited to testing a diverse range of materials such as asphalt, soil, unbound granular materials, fibres and plastics.

The DTS-30 is underpinned by Pavetest's leading edge CDAS digital controller, TestLab software and a full complement of accessories, hardware and software in perfect unison.

The DTS-30 Dynamic Testing System is compact, fully integrated, user and environmentally friendly.

The machine includes:

- 150 kN Load frame
- 30 kN Servo-hydraulic actuator (100 mm Stroke)
- 2.2 kW Hydraulic Power Supply
- 16 Channel Control and Data Acquisition System (CDAS) & TestLab software (see page 104)
- Load cell (± 30 kN)
- 100 mm actuator LVDT

MAIN FEATURES:

- Compact, robust (150 kN) load frame
- Small footprint; 90 cm x 135 cm, including hydraulic power supply and climatic chamber
- Reaction frame embedded in the test chamber
- Portable temperature control unit
- Fully configurable to suit a large range of testing applications
- Digital Servo-Hydraulic control
- 4 axis control and 16 channel data acquisition as standard

ADVANTAGES:

- The DTS-30 fatigue rated, servo-hydraulic actuator utilizes metal labyrinth bearings and seals.
The labyrinth bearings and seals are designed to reduce friction and maintain low operating temperatures.
The bearings experience little-to-no wear; operate at high speeds and offer a long service life.
- The speed of the HPS pump motor is controlled using a variable-frequency drive (VFD), or inverter drive.
This enables the motor to be slowed down, or turned off, when the oil flow from the pump exceeds the flow required by the actuator at any given time. This not only reduces noise and heat generation but also offers cost savings, by reducing power consumption.
Furthermore, the HPS can operate at 50 Hz or 60 Hz.

TECHNICAL SPECIFICATIONS:

- Load frame Between Columns 600 mm
 Vertical Space 800 mm
- Servo actuator Capacity ± 30 kN
 Frequency up to 100 Hz
 Stroke 100 mm
- Hydraulic Power Supply Pressure up to 160 bar; user defined
 Flow rate up to 7,5 litres/min
 Dimensions: 650(h) x 550(d) x 450(w) mm
 Power Supply: 230V 50/60 Hz 1 ph 2.5 kW
- Temperature Control Cabinet -20°C +80°C

Power Supply: 230V 50/60 Hz 1 ph 2.5 kW (B230)
230V 50 Hz 1 ph 1.3 kW (B231)

Dimensions: 2100(h) x 900(d) x 700(w) mm with temperature controlled cabinet



B230 30 kN Servo-Hydraulic Dynamic Testing System with B231 temperature controlled cabinet

NEEDED ACCESSORIES:

B231 Temperature controlled cabinet:
-20°C to +80°C to suit DTS-30

or

B232 Temperature controlled cabinet:
-40°C to +80° to suit DTS-30

RECOMMENDED ACCESSORIES:

H009-01 PC complete with LCD monitor 22", keyboard, mouse, cables and installation of Testlab software

B250-07 KIT Temperature measuring kit (see page 106)

We can upgrade your existing UTM (also from other manufacturers)

TEST CONFIGURATIONS and RELATED JIGS:

consult the following pages



WHAT MAKES IT DIFFERENT MAKES IT BETTER!

The DTS-30 is Universal Testing Machine (UTM), but not as most people know it. It does not conform to the “me too” attitude of most UTM manufacturers. The innovations featured on the DTS-30 are built on many years of experience, developing, studying and using various universal testing machines from a number of manufacturers.

The first thing you will notice about the DTS-30 is the absence of a reaction frame. **The reaction frame** most certainly exists, but it's **embedded in the test chamber**. This provides a very sleek appearance, maximizes the space inside whilst reducing the space required outside.

Since it is mandatory to control the test temperature of most pavement materials, e.g. asphalt, **the test chamber is insulated and forms part of the temperature controlled cabinet**.

Most UTM manufacturers opt for an elaborate (and expensive) moveable crosshead, only to find that its range (and usefulness) is limited by the climatic chamber:

The DTS-30 has a remotely positioned reaction shaft that adjusts the work space. However; you won't need to adjust it often because the **servo-hydraulic actuator has 100 mm of stroke**.

PORTABLE TEMPERATURE CONTROL UNIT

The temperature control unit attaches to the test chamber using a magnetic seal and can be wheeled away when not required or for servicing.

This also makes servicing, replacing or upgrading the temperature control unit virtually effortless: it can be removed without dismantling the machine or disrupting the testing program.



B230 DTS-30 Dynamic Testing System, open

A BOTTOM LOADING MACHINE

Before this current crop of universal testing machines, many dynamic testing machines were bottom loading.

More recently, the Asphalt Mixture Performance Tester (AMPT) changed the mindset of the testing community by highlighting the benefits of a bottom loading machine.

Firstly, **it is a neat, compact and integrated solution**, that places all hydraulic components within easy reach: gone are the long hydraulic hoses that run up and down the side of the machine and got in the way. They have been replaced by **shorter hoses that connect the actuator to the hydraulic power supply** that's tucked neatly away behind the machine, under the test chamber.

Can't see the **Control and Data Acquisition System (CDAS)**? That's because **it's housed neatly, in the cabinet in front of the machine**.

You won't see a tangle of cables either; they enter the cabinet through the floor of the test chamber or through the back of the cabinet and connect to the CDAS.

The door of the cabinet can be held ajar to allow transducers to be re-allocated or opened completely for servicing. Unused transducers can also be stored out of harm's way.

Moreover, the DTS-30 reaction frame is symmetrical; **the servo-hydraulic actuator and reaction shaft can be interchanged to make the DTS-30 top loading**.



B206 16 Channel CDAS

section B



109

PRIVETEST
WITH PERFORMANCE IN MIND

MATTEST

section B



110

PAVETEST

MATEST

| TESTING KIT | RELEVANT STANDARD(S) | WITH DYNAMIC SYSTEM | ACCESSORIES | PICTURE |
|---|---|--|---|---------|
| <p>B250 KIT • IDTM Indirect Tensile Modulus Comprises: B250-01 Basic IDT Jig B250-08 Yoke B250-09 Assembly for B250 KIT B290-01 LVDT (0,2 mm) (2 pieces)</p> | <p>AASHTO TP31 Resilient modulus of bituminous mixtures by indirect tension ASTM D4123 Indirect Tension Test for Resilient Modulus of Bituminous Mixtures AS/NZS 2891.13.1 Resilient modulus of asphalt - Indirect tensile method EN 12697-26 Annex C - Indirect tension to cylindrical specimens (IT-CY)</p> | <p>B220-01 KIT Manual DTS-16 with Climatic chamber (B221) B220-02 KIT Motorized DTS-16 with Climatic chamber (B221) B230 DTS-30 with Climatic chamber (B231 or B232) B240 DTS-130 with Climatic chamber (B241 or B242)</p> | <p>B250-03 Asphalt proving ring B250-04 100 mm diameter PVC specimen B250-05 150 mm diameter PVC specimen B250-06 KIT Torque screwdriver (B250-13) with hexagonal head 4 mm (B250-14)</p> | |
| <p>B251 KIT • IDTF Indirect Tensile Fatigue Comprises: B250-01 Basic IDT Jig B290-03 LVDT, double ball ended (3,75 mm) (2 pieces) B251-01 LVDT mounting strip gluing jig</p> | <p>EN 12697-24 Annex E - Indirect tensile test on cylindrical shaped specimens</p> | <p>B220-01 KIT Manual DTS-16 with Climatic chamber (B221) B220-02 KIT Motorized DTS-16 with Climatic chamber (B221) B230 DTS-30 with Climatic chamber (B231 or B232) B240 DTS-130 with Climatic chamber (B241 or B242)</p> | <p>B251-51 Pair of LVDT mounting strip to suit 100 mm specimen (needed accessory) And/or B251-52 Pair of LVDT mounting strip to suit 150 mm specimen (needed accessory) B201-52 5 Minute, two part epoxy 24 mL</p> | |
| <p>B260 KIT • UCC Uniaxial cyclic compression Comprises: B260-01 Base assembly B260-02 Chamfered top platen B290-02 LVDT (10 mm) (2 pieces)</p> | <p>EN 12697-25 Cyclic compression. Test Method A - Uniaxial cyclic compression test with confinement</p> | <p>B220-01 KIT Manual DTS-16 with Climatic chamber (B221) B220-02 KIT Motorized DTS-16 with Climatic chamber (B221) B230 DTS-30 with Climatic chamber (B231 or B232) B240 DTS-130 with Climatic chamber (B241 or B242)</p> | | |
| <p>B253 KIT • IDTOS Indirect Tensile modulus, creep compliance and strength using on-specimen transducers Comprises: B250-01 Basic IDT Jig B253-01 AASHTO T322 LVDT mounting kit B290-04 Miniature LVDT (1 mm) (4 pieces) B253-02 AASHTO T322 gauge point template (100 mm specimen) B253-03 AASHTO T322 gauge point template (150 mm specimen)</p> | <p>ASTM D7369 Resilient Modulus of Bituminous Mixtures by Indirect Tension Test AASHTO T 322 Creep Compliance and Strength of Hot-Mix Asphalt (HMA) Using the Indirect Tensile Test Device</p> | <p>B220-01 KIT Manual DTS-16 with Climatic chamber (B221) B220-02 KIT Motorized DTS-16 with Climatic chamber (B221) B230 DTS-30 with Climatic chamber (B231 or B232) B240 DTS-130 with Climatic chamber (B241 or B242)</p> | <p>B253-51 Short gauge point (needed accessory) B253-52 Long gauge point (needed accessory) B201-52 5 Minute, two part epoxy 24 mL</p> | |
| <p>B212 • 4PB Four Point Bending for use with Pavetest B230</p> | <p>AASHTO T 321 Fatigue Life of Compacted Hot-Mix Asphalt (HMA) Subjected to Repeated Flexural Bending ASTM D7460 Fatigue Failure of Compacted Asphalt Concrete Subjected to Repeated Flexural Bending AG:PT/T233 & ASTM 03 Fatigue life of compacted bituminous mixes subject to repeated flexural bending EN 12697-24 Annex D - Four point bending test on prismatic shaped specimens EN 12697-26 Annex B - Four point bending test on prismatic specimens (4PB-PR)</p> | <p>B230 DTS-30 with Climatic chamber (B231 or B232)</p> | <p>B210-02 4PB PVC Beam B210-03 4PB Reference beam</p> | |
| <p>B280 KIT • 2PB Two Point Bending (2PB) to suit B230. Comprises: B280-01 2PB Jig B280-51 2PB Mounting plate (25 mm apex) B280-52 2PB Mounting plate (50 mm apex) B280-53 2PB Mounting plate (base)</p> | <p>EN 12697-24 Annex A - Two-point bending test on trapezoidal shaped specimens (2PB-TR) EN 12697-26 Annex A - Two point bending test on trapezoidal specimens (2PB-TR)</p> | <p>B230 DTS-30 with Climatic chamber (B231 or B232)</p> | <p>B290-05 LVDT (2 mm) (needed accessory) B280-02 Two point Bending (2PB) gluing jig B201-52 5 Minute, two part epoxy 24 mL</p> | |

| TESTING KIT | RELEVANT STANDARD(S) | WITH DYNAMIC SYSTEM | ACCESSORIES | PICTURE |
|--|---|--|--|--|
| <p>B261 KIT • PD Permanent deformation Comprises: B260-01 Base assembly B260-03 100 mm top platen B290-02 LVDT (10 mm) (2 pieces)</p> | <p>AS/NZS 2891.12.1 Determination of the permanent compressive strain characteristics of asphalt - Dynamic creep test</p> | <p>B220-01 KIT Manual DTS-16 with Climatic chamber (B221) B220-02 KIT Motorized DTS-16 with Climatic chamber (B221) B230 DTS-30 with Climatic chamber (B231 or B232) B240 DTS-130 with Climatic chamber (B241 or B242)</p> | <p>B260-04 150 mm top platen</p> |  <p>B261 KIT B262 KIT</p> |
| <p>B255 KIT • E* Dynamic modulus Comprises: B200-02 105 mm bottom loading platen B200-03 105 mm top loading platen B253-04 AASHTO T342 LVDT mounting kit (3 pieces) B290-06 LVDT (1 mm) (3 pieces) B253-05 Screwdriver hex bit with spherical head size 2 mm</p> | <p>AASHTOT342 Determining Dynamic Modulus of Hot Mix Asphalt (HMA)</p> | <p>B230 DTS-30 with Climatic chamber (B231 or B232) B240 DTS-130 with Climatic chamber (B241 or B242)</p> | <p>B202 AMPT Gauge Point Fixing Jig B203 AMPT Dynamic Verification Device B253-53 AASHTOT342 gauge point B201-52 5 Minute, two part epoxy 24 mL</p> |  |
| <p>B271 KIT • CCT Cyclic triaxial compression Comprises: B270-01 Modified triaxial cell, suitable for 100 mm dia., up to 200 mm height specimens B270-02 Triaxial cell external LVDT mounting kit B293-02 Pressure transducer (± 600 kPa) B270-05 110 mm diameter bottom platen assembly for EN 12697-25B B270-06 110 mm diameter top loading platen for EN 12697-25B B270-13 Distance piece 50 mm height B270-14 Distance piece 100 mm height</p> | <p>EN 12697-25 Cyclic compression. Test Method B - Triaxial cyclic compression test</p> | <p>B220-01 KIT Manual DTS-16 with Climatic chamber (B221) B220-02 KIT Motorized DTS-16 with Climatic chamber (B221) B230 DTS-30 with Climatic chamber (B231 or B232) B240 DTS-130 with Climatic chamber (B241 or B242)</p> | <p>B270-04 Air reservoir assembly confining pressure upgrade kit (needed accessory for DTS-16) or B270-03 Air reservoir assembly with confining pressure control (needed accessory for DTS-30/130) B290-02 Displacement transducer (10 mm) (2 pieces needed) Requires pressurized air; minimum 7 bar (not included)</p> |  |
| <p>B272 KIT • TRM Triaxial resilient modulus Comprises: B270-01 Modified triaxial cell, suitable for 100 mm dia., up to 200 mm height specimens B270-02 Triaxial cell external LVDT mounting kit B293-02 Pressure transducer (± 600 kPa) S315-07 100 mm diameter bottom platen S314-03 100 mm diameter top platen</p> | <p>AASHTOT307 Determining the resilient modulus of soils and aggregate materials</p> | <p>B220-01 KIT Manual DTS-16 with Climatic chamber (B221) B220-02 KIT Motorized DTS-16 with Climatic chamber (B221) B230 DTS-30 with Climatic chamber (B231 or B232) B240 DTS-130 with Climatic chamber (B241 or B242)</p> | <p>B270-04 Air reservoir assembly confining pressure upgrade kit (needed accessory for DTS-16) or B270-03 Air reservoir assembly with confining pressure control (needed accessory for DTS-30/130) B290-02 Displacement transducer (10 mm) (2 pieces needed) Requires pressurized air; minimum 7 bar (not included)</p> |  |
| <p>B254 KIT • SCB Semi-Circular Bending Comprises: B254-01 SCB kit B254-51 SCB wear plate (2 pieces)</p> | <p>EN 12697-44 Tensile Strength and Fracture Toughness-Crack Propagation</p> | <p>B220-01 KIT Manual DTS-16 with Climatic chamber (B221) B220-02 KIT Motorized DTS-16 with Climatic chamber (B221) B230 DTS-30 with Climatic chamber (B231 or B232) B240 DTS-130 with Climatic chamber (B241 or B242)</p> | <p>B250-01 Basic Indirect Tensile Jig (needed accessory) B290-07 Deformation gauge (needed accessory)</p> |  |
| <p>B282 KIT • TSRST Thermal Stress Restrained Specimen Test Comprises: B282-01 TSRST Temp. Transducer (-80°C to +80°C) (3 pieces) B282-02 Rod End (2 pieces) B282-03 Clevis Yoke and Pin (2 pieces) B282-04 Platen (2 pieces) B282-05 LVDT Holder (2 pieces) B282-06 Invar Rod (250 mm long) (2 pieces)</p> | <p>AASHTO TP10 Thermal Stress Restrained Specimen Tensile Strength EN 12697-46 Low Temperature Cracking and Properties by Uniaxial Tension</p> | <p>B230 DTS-30 with Climatic chamber (B232) B240 DTS-130 with Climatic chamber (B242)</p> | <p>B290-09 Displacement transducer for TSRST (2 pieces needed) B282-07 Tension platen gluing jig (2 pieces needed)</p> | |



Marshall compression frames

Available models:

B042 KIT Marshall mechanical load frame

B043 KIT Marshall digital load frame

S212N-S215A Universal Multispeed load frame (see pag. 408)

S213N-S214 KIT CBR/Marshall dual speed load frame (see pag. 408)

S205 UNITRONIC load frame (see pag. 414)

section B

B042 KIT

Marshall mechanical 50 kN load frame

STANDARDS: EN 12697-34, EN 13108 / ASTM D1559, D6927-06

AASHTO T245 / BS 598:107 / NF P98-251-2

CNR N° 30

Ruggedly constructed with frame to encompass the strain and loads, easy to use, it is designed to operate with the minimum of maintenance.

Platen rate is 50.8 mm/minute also maintained under load thanks to an overpowered electric motor. The applied load is measured by a precision proving ring 30 kN capacity incorporating a stem brake holding the maximum reading and it is supplied with relevant calibration certificate. The machine includes an electric device for automatic stop when reaching the max capacity load of the proving ring, so as to prevent any overload damage, limit switches stopping the platen at max. and min. excursions.

The unit is supplied complete with load ring 30 kN capacity, stability mould flow meter with dial gauge.

Power supply: 230V 1 ph 50 Hz 750 W

Dimensions: 410x400x1110 mm

Weight: 110 kg

SPARES:

B046N

STABILITY MOULD, 4" Ø

STANDARDS: EN, ASTM, NF, BS, CNR, AASHTO

The inside diameter is of 4" (101,6 mm).

The mould is completely open in the front and the introduction of the specimen becomes very easy thus avoiding disassembling operations.

Weight: 6 kg

B047 FLOW METER

Mounted on top of the stability mould, holding the dial gauge and incorporating a stem-brake keeping maximum deflection.

Weight: 0,5 kg

B047-01

DIAL GAUGE

Stroke 10 mm, div. 0,01 mm to be used in conjunction with the Flow Meter B047.



B046N

B047-01

B047

B042 KIT



ACCESSORIES:

B047-02

Tensile splitting device

STANDARDS: EN 12697-23 / ASTM D4123 / CNR 134

Used to measure the splitting tensile strength and the radial strain of a Marshall specimen dia 4" and 6", where a vertical load is applied. Supplied complete with knives to test specimens having dia. 4" and 6". Steel manufactured, plated against corrosion.

Dimensions: dia. 248x270 mm. - Weight: 14 kg

B047-03

Set of two dial gauges 10 mm. stroke and 0,01 mm. sens. complete with adjustable supports for strain measurements.

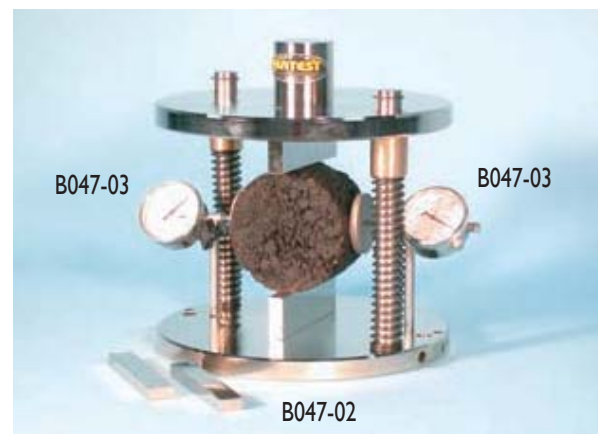

B047-03

B047-03

B047-02



112

B043 KIT
Digital Marshall Tester 50 kN capacity

STANDARDS: EN 12697-34, 12697-23, 12697-12, EN 13108
 ASTM D1559, D6927-06 / AASHTO T245 / BS 598:107
 NF P98-251-2 / CNR N° 30

The testing frame is the same as for mod. B042 KIT, but the load is measured by an electric cell 50 kN capacity with high precision strain transducers; the flow is measured by an electronic displacement transducer 50 mm stroke and ± 0,1% linearity. The **Cyber-Plus Evolution** 8 channels digital display unit with microprocessor (technical details: see B044N-SET page. 122, Hardware technical details: see pag. 24) measures and displays at the same time the stability in kN and the flow in mm with pick hold features with the possibility to transfer them to a PC and a printer through a RS232 port.

Supplied complete with Stability mould.
 Power supply: 230V 1 ph 50 Hz 900 W
 Dimensions: 650x400x1100 mm. Weight: 120 kg

ACCESSORIES for B043 KIT:

B043-01N
 SOFTWARE UTM2 (Universal Testing Machine 2)
 Licence for **MARSHALL** test
 Standards: EN 12697-34 / CNR N. 30 / ASTM D1559
 BS 598 :107 / NF P98-251-2

Data processing program for "X-Y STABILITY/FLOW"
 General description and technical details: see UTM2 pag. 14

SPARE:

B046N
 STABILITY MOULD 4" Ø
 STANDARDS: EN, ASTM, NF, BS, CNR

The inside diameter is 4" (101,6 mm); the mould is completely open in the front and the introduction of the specimen becomes very easy thus avoiding disassembling operations.
 Weight: 6 kg



B046 N

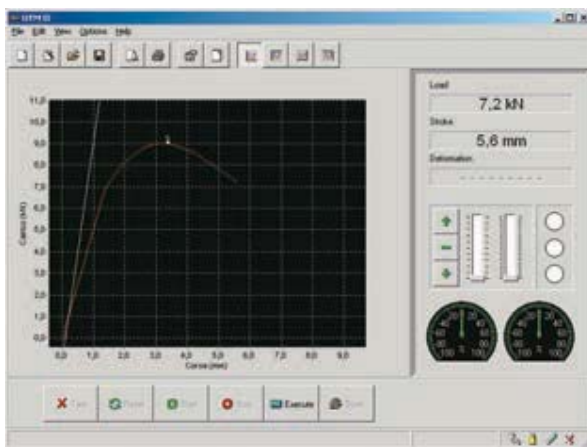

B043-01N: Load/deformation "x-y" graphic exemple



B043 KIT

Note:

The Digital Marshall Tester B043KIT, completed by the specific accessories (listed below) is suitable to perform also the following tests:

Direct shear (Leutner) between bituminous strata

Standard: ALP A StB.T.4

Direct shear test (LEUTNER) on the connection between bituminous strata, carried out on asphalt cylinder specimens dia. 150mm or 100mm obtained from road cores or on laboratory made specimens. Needed accessories:

- B043 KIT** Digital Marshall tester
- B047-10** LEUTNER testing head for specimens 150mm dia.
- B047-11** Spacers for 100 mm dia. specimens with Leutner head.
- B043-03N** Software for Marshall and Leutner tests.



B047-10 + B047-11

... follows ...

section B



DETERMINATION OF INDIRECT TENSILE STRENGTH

STANDARDS: EN 12697-23 / ASTM D4123 / CNR N.134

Equipment: Digital Marshall Tester B043 KIT, and:

B047-02

TENSILE SPLITTING DEVICE FOR SAMPLE DIA. 4" AND 6"

Used to measure the indirect tensile strength and the radial strain of a Marshall specimen dia. 4" and 6", where a vertical load is applied.

Supplied complete with loading knives to test specimens having dia. 4" and 6".

Steel manufactured, plated against corrosion.

Dimensions: dia. 248 x 270 mm

Weight : 14 kg

B047-04

SET OF TWO LINEAR RESISTIVITY TRANSDUCERS,

stroke 10 mm, accuracy and linearity +/- 0,3%.

Complete with supports and accessories for strain measurements.

B044-03

DISPLACEMENT TRANSDUCER, "additional", 50 mm stroke, for a double measurement of the vertical displacement of the specimen during the tensile splitting test. Complete with cable and connector. When used with B043-02N software the average value of the two transducers is given.

B043-02N

SOFTWARE UTM2 (Universal Testing Machine 2)

Licence for **INDIRECT TENSILE STRENGTH**

Standards: EN 12697-23 / ASTM D4123 / CNR N. 134

General description and technical details: see UTM2 pag. 14

GAUGE BLOCKS. Grade I

Used to calibrate the linear displacement transducers.

Models:

S336-43 Gauge block, nominal length 10 mm

S336-47 Gauge block, nominal length 50 mm

Technical details: see pag. 453

DETERMINATION OF WATER SENSITIVITY OF BITUMINOUS SAMPLES

STANDARDS: EN 12697-12, EN 13108

This test determines the effect of saturation and accelerated water conditioning on the indirect tensile strength of bituminous mixtures, by evaluating the effect of moisture with different sample conditions.
Equipment: Digital Marshall tester B043KIT, indirect tensile strength accessories, and also:

B052-02

Water bath, digital, with cooling device

Temperature range: +3 to +95°C., accuracy +/- 1°C.

(EN 12697-12 and 12697-23 Standard require a temperature to be selected in the range of +5 to +25°C.)

Capacity: 45 litres

Inside dimensions: 635x360x205 mm

The bath can also be used for Marshall tests and general laboratory purposes. Technical details: see pag. 125

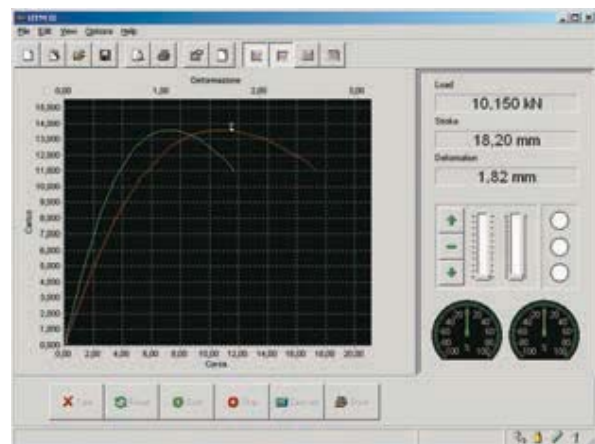
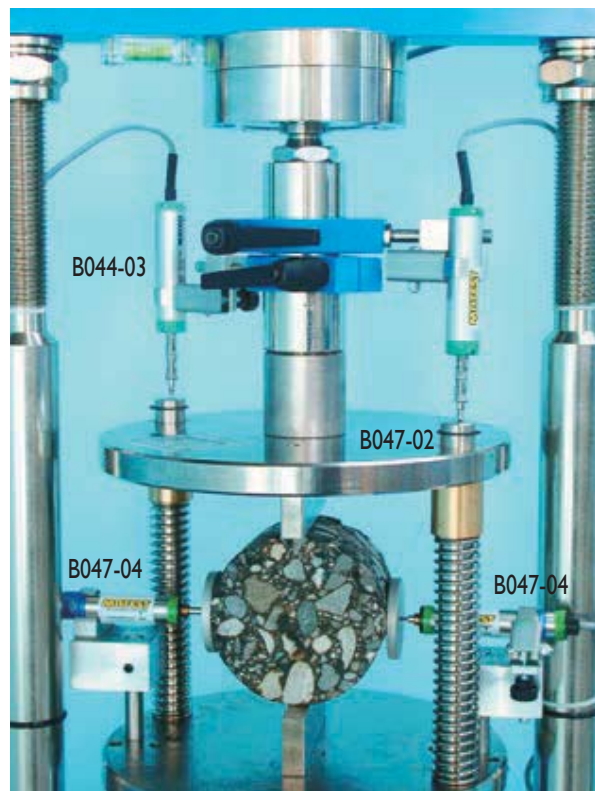

B043-02N: Test report



B052-02



MULTI-FUNCTION TESTING FRAMES, ALSO SUITABLE FOR MARSHALL TESTS

S213N

CBR/Marshall 2 speeds frame 50 kN

The frame is provided of two fix speed ranges, easily selectable by a frequency changer (inverter) activated by an electric switch:

1,27 mm/min. for CBR tests

50,8 mm/min for Marshall tests.

Supplied "without" load ring and accessories which have to be ordered separately.

Technical detail: see pag. 408



S213N
with accessories for Marshall test

S212N

Universal multispeed load frame 50kN, digital, Touch-Screen

This motorized machine with electronic digital "touch-screen" controlled by microprocessor; is suitable to perform all the tests where the requested speed rate is within:

"0,05 to 63 mm/min" with max. load of 50 kN

It can therefore perform:

- Marshall test with rate of 50.8 mm/min.
- Splitting tensile test on Marshall specimens.
- Unconfined, CBR tests.

Supplied "without" load ring and accessories which have to be ordered separately (see accessories).

Power supply: 230V I_{ph} 50/60Hz 750W

Technical Specifications: see page 408



S212N

ACCESSORIES for S212N and S213N frames:

MARSHALL test, 4" Ø:

- S212-05** Load piston
- B046N** Stability mould 4" Ø
- B047** Flow meter
- B047-01** Dial gauge for flow meter
- S370-08S** Load ring 30kN with electric stop safety device
- S374** Brake device to hold max. load

MARSHALL test 6" Ø (with S212N frame only)

STANDARD: ASTM D5581-96

- S212-05** Load piston
- B046-02** Stability mould 6" diameter
- B047** Flow meter
- B047-01** Dial gauge for flow meter
- S370-10S** Load ring 50kN with electric stop safety device
- S374** Brake device to hold max. load

NOTE:

The frames S212N and S213N are suitable also for tensile splitting tests (EN 12697-23) by using the specific devices described at pag. 112, 114



B046-02

...follows...

section B



115

MATTEST

MULTIFUNCTION TESTING FRAMES:

COMBINED WITH "CYBER-PLUS 8 EVOLUTION", COMPUTERIZED DIGITAL DISPLAY SYSTEM

Technical Specifications:

The frame is the same as for the previous load frames (mod. S212N - S213N), but the load is measured by an electric 50kN cell with high precision strain transducers. The deformation (flow) is measured by a displacement transducer 50 mm stroke and +/- 0,1% independent linearity.

The "CYBER-PLUS 8 EVOLUTION" computerized multichannel digital display system (technical details: see mod. B044N-SET at page 122), measures and displays at the same time the load (stability) in kN and the deformation (flow) in mm with pick hold features and possibility to print certificates and graphics directly on a laser printer via USB or to transfer them to PC via Ethernet.

AVAILABLE MODELS:

S214N KIT

CBR/Marshall 2 speed load frame digital, computerized

Technical details of the frame: see mod. S213N, pag. 408

Supplied complete with "Cyber-Plus 8 Evolution" system (B044N-SET, details at pag. 122, Hardware details at pag. 24), load cell and displacement transducer, but "without" accessories to be ordered separately.

S215A

Universal multispeed load frame digital, touch-screen, computerized "Cyber-Plus 8 Evolution"

Technical Spec. of the frame: see mod. S212N at page 408

Technical Spec. of S215A: see page 410

Supplied "without" accessories for Marshall, CBR, Unconfined tests and Software, to be ordered separately (see accessories).



S214N KIT + accessories MARSHALL

SOFTWARES FOR THE FRAMES COMBINED WITH "CYBER-PLUS 8" SYSTEM:

B043-01N SOFTWARE UTM2 (Universal Testing Machine 2)
Licence for **MARSHALL** test
Standards: **EN 12697-34 / CNR N. 30 / ASTM D1559**

B043-02N SOFTWARE UTM2 (Universal Testing Machine 2)
Licence for **TENSILE SPLITTING** test
Standards: **EN 12697-23 / CNR N. 134 / ASTM D4123**

Description and technical details of Software UTM2: see pag. 14

H009-01 PERSONAL COMPUTER, complete with LCD monitor 22", keyboard, mouse, connection cables, installation and setting up of the purchased software.

C128 Laser printer; for the graphic and test certificate printing, to be connected directly to Cyber-Plus 8 through USB.

NOTE: The frames S214N KIT and S215A are suitable also for tensile splitting and direct shear (Leutner) test, by using the specific devices described at pag. 113



S215A + accessories MARSHALL

ACCESSORIES FOR THE FRAMES, MOD. S214N KIT AND S215A MARSHALL tests

- S212-05** Load piston
- B046N** Stability mould 4" Ø
- B046-02** Stability mould 6" Ø (with S215A frame only)
Standard: ASTM D5581-96



B046-02



[Descrizione]
Rate: 60.000 mm/min
Stop load: 10 %
Diameter: 120.000 mm
Profile: 1
200kN
6/21/2013
10:44 AM

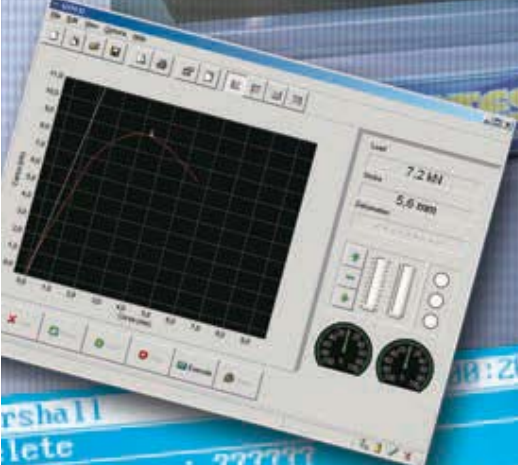

Marshall
Complete
Test ID : 777777
Date/time : 01/01/00 08:09
Top type : MANUAL
Load : 11.92000 kN
Displacement : 5.75000 mm

section B



117

MATEST

S205

UNITRONIC 50 kN, UNIVERSAL MULTIPURPOSE COMPRESSION/FLEXURAL AND TENSILE FRAME FOR:

- COMPRESSION / FLEXURAL TESTS, 50 kN MAX. CAPACITY LOAD
- TENSILE TESTS, 25 kN MAX. CAPACITY LOAD (accessory mod. S205-05)

WITH AUTOMATIC LOAD OR DISPLACEMENT/DEFORMATION CONTROL, for testing:

Asphalt:

- MARSHALL
- SPLITTING TENSILE
- DIRECT SHEAR (Leutner) on the connection between bituminous strata

Soil:

- CBR (California Bearing Ratio),
- UNCONFINED COMPRESSION,
- QUICK TRIAXIAL

Concrete:

- FLEXURE ON BEAMS
- FLEXURE ON TILES

Cement:

- FLEXURE on 40x40x160mm specimens,
- COMPRESSION on cubes 40, 50, 70mm
- TENSILE on mortar briquettes (accessory mod. S205-05)

Metal, plastic, wires, ropes, textiles, papers etc.

- TENSILE TESTS, 25kN max capacity load (accessory mod. S205-05)

Clay blocks:

- PUNCHING

Rock and stones:

- UNIAXIAL SPLITTING TENSILE

Various materials:

By using suitable devices, Unitronic tester, within the limits of its max. 50 kN capacity for compression/flexural and 25 kN for tensile (see accessory S205-05), performs compression, flexural, splitting tensile and direct tensile tests, with automatic load or displacement/deformation control.

The load is applied by a mechanical jack that is driven by a motor "brushless with closed loop through optic encoder" and controlled by a microprocessor. Stroke electric end switches are applied to the load piston to save the machine from accidental handlings. The control panel is placed frontally and it is provided with a membrane having 6 multifunctional interactive pushbuttons driven by menu, a large graphic display and RS232 port for connection to PC.

Hardware and software specifications:

- Negative blue graphic display "320 x 240 pixel"
- 4 analogue A/D outputs for transducers or load cells.
- Permanent memory and clock calendar
- Fully automatic test processing with real time acquisition and visualization of the load/displacement or deformation, curve load/time/deformation.
- Memory of more than 100 tests, with possibility to display/delete tests from the file storage
- Multi-languages function: Italian, English, French, Spanish

Technical data:

- Maximum compression capacity: 50kN
- Maximum tensile capacity: 25kN (accessory S205-05)
- Adjustable testing speed from 0,01 to 51mm/minute
- Adjustable pace rate from 1 to 15000N/sec.
- Max. ram travel: 100mm
- Daylight between columns: 380mm
- Max. vertical daylight: 850mm
- Power supply: 230V 1F 50/60Hz 1500W
- Dimensions: 500x450x1450mm. Weight: 130 kg approx



S205
with load
cell

NOTE:

Additional specific applications for tests on:

- Soil, Rock
- Concrete, Clay Blocks
- Cement
- Tensile tests etc.

are listed with technical details, accessories, pictures at pag. 414



S205

UNITRONIC 50 kN, SPECIFIC APPLICATIONS ON BITUMINOUS MATERIALS:

Marshall stability test

Standards: EN 12697-34 / ASTM D1559 / AASHTOT245
BS 598 :107 / NF P98-251-2 / CNR N° 30

Test development with displacement control.

Needed accessories:

- S337-34** Strain gauge load cell, 50 kN capacity.
- S212-05** Loading piston.
- B046N** Stability mould.
- B043-01** Software for Marshall test.

Splitting tensile test

Standards: EN 12697-23 / ASTM D4123 / CNR N° 134
Test development with displacement control.

Needed accessories:

- S337-34** Strain gauge load cell, 50 kN capacity.
- S212-05** Loading piston.
- B047-02** Splitting tensile device for samples dia. 4" and 6"
- B047-04** Set of TWO displacement transducers with accessories.
- B043-02** Software for Splitting Tensile test.



File Marshall test

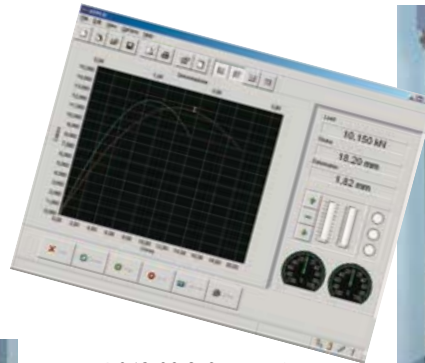

B043-02 Software splitting tensile test

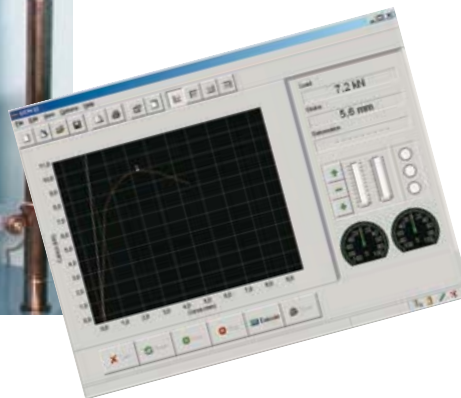

B043-01 Software Marshall test

Direct shear (Leutner) between bituminous strata

Standard: ALP A StB.T.4

Direct shear test (LEUTNER) on the connection between bituminous strata, carried out on asphalt cylinder specimens dia. 150mm or 100mm obtained from road cores or on laboratory made specimens.

Test development with displacement control.

Needed accessories:

- S337-34** Strain gauge load cell, 50 kN capacity.
- S212-05** Loading piston.
- B047-10** LEUTNER testing head for specimens 150mm dia.
- B047-11** Spacers for 100 mm dia. specimens with Leutner head.
- B043-03** Software for Marshall and Leutner tests.



NOTE:

Needed accessories listed above, are common for different tests. We recommend to check them when ordering, to avoid duplications.

Additional specific applications described at pag. 414



S206N

UNITRONIC 200kN “Matest made”

UNIVERSAL ELECTROMECHANICAL FRAME, 200kN CAPACITY,
“TOUCH-SCREEN” FOR:

- COMPRESSION
- FLEXURE
- TENSILE

TESTS OF CONSTRUCTION MATERIALS WITH SERVO-CONTROLLED SYSTEM OF LOAD OR DISPLACEMENT/STRAIN.

section B

Unitronic 200kN is the universal and versatile machine fully satisfying the needs of control, research and university laboratories to carry out tests on:

Roads (Marshall, Duriez, CBR etc.), Steel, Concrete, Cement, Wood, Plastic, etc.

The machine is composed by a sturdy base containing the transmission components and the hardware control instruments.

The base holds two columns, made of high resistance steel with ground hard chrome surfacing.

The upper crosshead can be adjusted in height, to hold the accessories to perform the specific tests.

The lower mobile crosshead is operated by a recirculating ball screw and rotating lead, that through a servo-controlled motor, assures the correct application of load and constant speed.

The load is applied by a mechanical jack activated by a **“brushless closed-loop motor with optical encoder”** controlled by a micro-processor.

The two crossheads foresee couplings to fix the different test devices (see accessories).

The stress is measured by an electric load cell; the measurement and the displacement control of the crosshead is achieved by the electronic device incorporated into the machine.

Stroke electric end excursion switches of the upper mobile crosshead are foreseen to save the machine from accidental handlings.

Firmware:

- Electronic control unit “Cyber-plus Evolution” with Touch-Screen colour display, that runs like a standard PC based on Windows operating system for the management and analysis of the data, test results, graphs.
- The Touch-Screen icon interface allows an easy set up of the parameters and immediate execution of the test.
- The machine can be connected to a PC for remote test execution through suitable Software; the machine can in any case perform the tests without any external PC, because of the “Cyber-Plus” grants performances like a PC.
- Direct connection to Intranet (connection to a LAN network) and Internet to establish a remote communication and receive an immediate diagnostic analysis from Matest technicians, or for updates of the software.
- Unlimited memory storage with: 2 USB ports, 1 SD card slot, RS232/485 serial port.
- Possibility to select different languages.
- Hardware technical details: see pag. 24



S206N

Specifications of the Frame:

- Max. load: 200 kN (both Compression and Tensile)
- Max. vertical daylight: 900 mm (without accessories)
- Max. vertical daylight with compression platens: 800 mm
- Compression platens diameter: 216 mm (upper platen on seat ball)
- Distance between columns: 650 mm
- Crosshead travel: +/- 200 mm (400 mm total)
- Testing speed range: from 0,01 to 100 mm/min
- Load rate: from 1 N/s to 5 kN/s
- Displacement resolution: 0,01 mm with accuracy better than 0,2%
- Machine Class: I

The Unitronic 200kN is **supplied complete with:**

Electric load cell 200kN capacity, crosshead displacement device, upper with seat ball and lower compression platens.

“Are not included”: accessories and software for specific tests that must be ordered separately (see accessories).

Note: The machine can be equipped with intermediate load cells to the max. capacity of the machine, to satisfy specific test requirements.

Power supply: 230V 1ph 50/60Hz 850W

Dimensions: 950 x 560 x 2400 mm. Weight: 820 kg



120

S206N

UNITRONIC 200 kN, specific applications:

Duriez test on 80 and 120 mm dia. samples

STANDARD: NF P98-251-1/4

- S206N** Unitronic 200 kN
- B096-01** Duriez set dia. 80 mm (see page 146)
- B095-01** Duriez set dia. 120 mm (see page 146)
- S206-21N** Software for Duriez test



B095-01

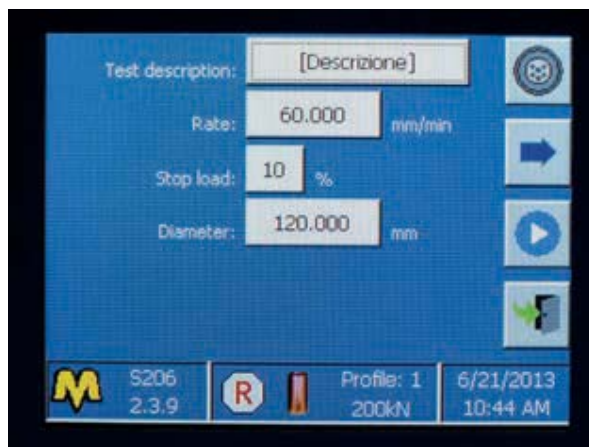

S206-21N Software for Duriez test

Direct shear (Leutner) between bituminous strata

STANDARD: ALP A StB t.4

Direct shear test (LEUTNER) on the connection between bituminous strata, carried out on asphalt cylinder specimens dia. 150mm or 100mm obtained from road cores or on laboratory made specimens.

- S206N** Unitronic 200 kN
- S337-34** Strain gauge load cell 50 kN capacity
- S206-31** Flange/connector of the load cell S337-34
- S212-05** Loading piston
- B047-10** LEUTNER testing head for specimens 150mm dia.
- B047-11** Spacers for 100mm dia. specimens with Leutner head
- B043-03N** Software for Leutner and Marshall tests.

Additional specific accessories for tests on:

Concrete and Mortar (compression, flexure, punching etc.) - Soils (CBR) - Steels (Tensile), are listed in soil section, pag. 420

Marshall stability test

STANDARDS: EN 12697-34 / ASTM D1559 / AASHTO T245 / BS 598:107 / NF P98-251-2 / CNR N°30

- S206N** Unitronic 200 kN
- S337-34** Strain gauge load cell 50 kN capacity
- S206-31** Flange/connector of the load cell S337-34
- S212-05** Loading piston
- B046N** Stability mould
- B043-01N** Software for Marshall test



B046N

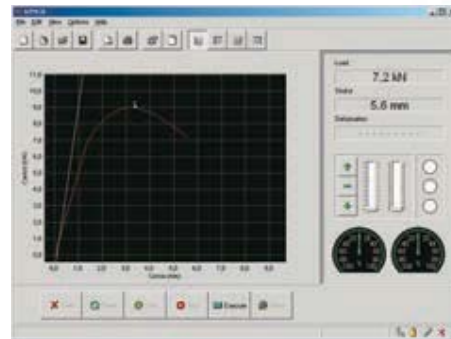

B043-01N Software for Marshall test

Splitting tensile test

STANDARDS: EN 12697-23 / ASTM D4123 / CNR N° 134

- S206N** Unitronic 200 kN
- S337-34** Strain gauge load cell 50 kN capacity
- S206-31** Flange/connector of the load cell S337-34
- S212-05** Loading piston
- B047-02** Splitting tensile device for samples dia. 4" and 6" (page 114)
- B047-04** Set of TWO displacement transducers with accessories (page 114)
- B043-02N** Software for Splitting Tensile test (page 14)



B047-02 + B047-04



B047-10 + B047-11

section B





B044N SET

B044N-SET

Cyber-Plus 8 Evolution “Touch-Screen”

Acquisition and data processing system. 8 channels.

Developed for the implementation and upgrading of any type of existing machines (even not manufactured by Matest) applicable to:

- Marshall mechanical load frame mod. B042 KIT.
- CBR/Marshall 2 speeds load frame mod. S213N.
- CBR loading machine motorized mod. S211 KIT.

Cyber-Plus 8 Evolution allows:

- Acquisition up to 8 analogical/digital channels: load cell and linear displacement potentiometric vertical and/or horizontal transducers.

To perform the following tests:

MARSHALL: **EN 12697-34** / ASTM D1559 / CNR N. 30
NF P98-251-2 / BS 598 :107

- INDIRECT TENSILE TEST: **EN 12697-23** / ASTM D4123
- DETERMINATION OF THE WATER SENSIBILITY OF BITUMINOUS SPECIMENS: **EN 12697-12**
- CBR TEST: **EN 13286-47** / CNR / UNI 10009
ASTM D1883 / BS 1377 / NF P94-078.
- UNCONFINED TEST: ASTM D2166
- Remote control of the digital unit through PC and UTMII software

Hardware specifications:

- 8 independent channels available for the load cells or potentiometric transducers or strain gages for load, deformation or displacement measurements..
- Stabilized power supply of the analogical channels: 5Vcc and 3Vcc
- Analogue input: +/- 20 mV and +/-5V
- Nominal resolution: 24 bit.
- Acquisition up to 200 readings for each channel.
- Safety discrete On/off output
- Graphic display ¼ VGA colour Touch-Screen.
- Time and calendar system

Firmware specifications:

- Instant visualization of the load measured by an extensometric cell.
- Instant visualization of the deformation measured by 4 linear displacement transducers.
- Visualization of the graphic of the test.
- Visualization of date and time.
- Semi-automatic configuration and calibration of all transducers connected.
- 20 steps lining that can be set by the enduser.
- Automatic correction of the axis origin for CBR/Marshall tests.
- Automatic calculation and visualization of all the results according to the Standard.
- Setting of all the parameters for test: alarms, zero threshold, end-test percentage, calculation parameters.
- Time/date and language selection (Italian, English, French, German, Spanish, Polish).
- Unlimited file for each type of test
- Symbols of pushbuttons functions
- Informative messages (planning alarms, load cell and strain transducer setting, etc.)
- Safety function for automatic machine stop at max. reached load and deformation of the strain transducer.
- Printing of the results on the incorporated thermal graphic printer (accessory C127N). Transfer and management via Ethernet of the filed data or real-time.

Hardware technical details: see pag. 24

B044N-SET is composed by:

B044N

CYBER-PLUS 8 EVOLUTION, Unit for data acquisition, as described
Power supply: 230V 1F 50/60Hz

S337-34

LOAD CELL, 50kN capacity, with high precision strain transducers, complete with cable and connector

S336-14

LINEAR DISPLACEMENT TRANSDUCER, 50mm stroke, independent linearity +/- 0,1% complete with cable and connector

Accessories for fixing the load cell and transducer to the test machine.

The system is supplied fully calibrated with calibration certificate, and ready for use.

Every item can be ordered separately.

ACCESSORIES:

B043-01N

SOFTWARE UTM2 (Universal Testing Machine 2)

Licence for **MARSHALL** test

Data processing program for "X-Y STABILITY/FLOW"

Standards: **EN 12697-34** / CNR N. 30 / ASTM D1559
BS 598 :107 / NF P98-251-2

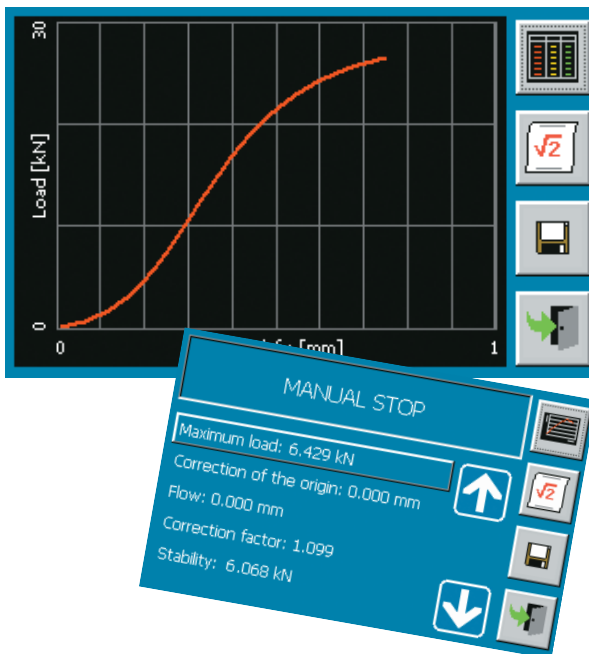

B043-02N

SOFTWARE UTM2 (Universal Testing Machine 2)

Licence for **INDIRECT TENSILE STRENGTH**

Standards: **EN 12697-23** / CNR N. 134 / ASTM D4123

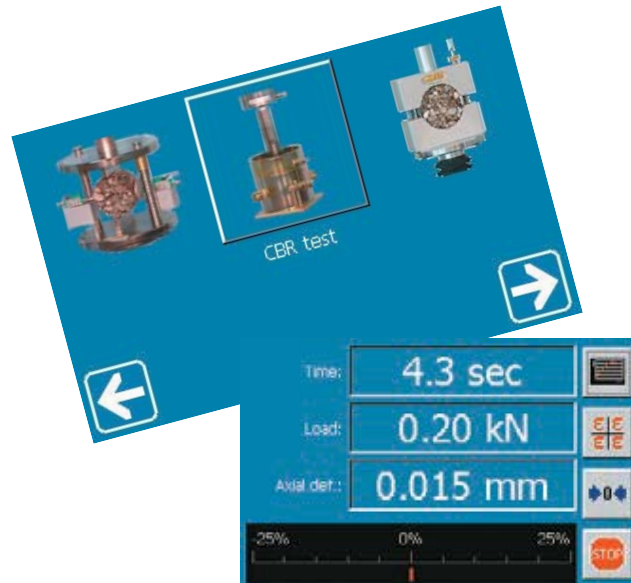

S218N

SOFTWARE UTM2 (Universal Testing Machine 2)

Licence for **CBR** Test

Standards: **EN 13286-47** / CNR/UNI 10009 / ASTM D1883
BS 1377 / NF P94-078

S218-01N

SOFTWARE UTM2 (Universal Testing Machine 2)

Licence for **UNCONFINED** Test

Standards: ASTM D1883

Description and technical details of Software UTM2: see pag. 14

C127N Graphic printer on thermo paper on board.

H009-01

PERSONAL COMPUTER, complete with LCD monitor 22", keyboard, mouse, connection cables, installation and setting up of the purchased software.

C128 Laser printer for test certificate and graphics printing with direct connection to CYBER-PLUS 8.



Water baths for Marshall specimens

STANDARDS: EN 12697-34, EN 13108 / ASTM D1559, D5581 / AASHTO T245

Used to maintain in water Marshall specimens at constant temperature of $60\text{ }^{\circ}\text{C} \pm 1\text{ }^{\circ}\text{C}$ and asphalt specimens at $37,8\text{ }^{\circ}\text{C} \pm 1\text{ }^{\circ}\text{C}$. These baths are also ideal for general laboratory use.

MODELS:

B051

Marshall water bath

The internal tank and cover are stainless steel made, outside box is from painted steel sheet with wool insulation. The specimens are held by a stainless steel perforated shelf spaced from the bottom. The bath has a capacity of 46 litres and is designed to hold up to 20 Marshall specimens.

Temperature range: from ambient to $95\text{ }^{\circ}\text{C}$.

Inside dimensions: $615 \times 505 \times 150\text{ mm}$

Overall dimensions: $660 \times 540 \times 230\text{ mm}$

The bath is supplied "without" thermostat and heating element to be ordered separately (see accessories).

Weight: 18 kg



B051



B051+B051-01

"NEEDED" ACCESSORY for the B051 Bath:

B051-01

THERMOSTAT ANALOGIC Heating System, complete with immersion heating element.

Power supply: 230V Iph 50/60Hz 1500W

In alternative:

B051-02

THERMOSTAT DIGITAL Heating System, complete with immersion heating element. The digital system ensures a better temperature accuracy control of the water at $60 \pm 1\text{ }^{\circ}\text{C}$ or $37,8 \pm 1\text{ }^{\circ}\text{C}$ as requested by Standards

Power supply: 230V Iph 50/60Hz 1500W

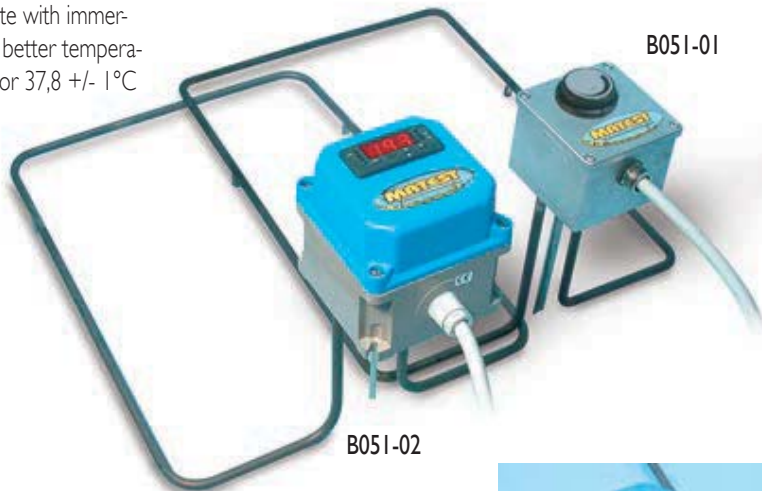

B051-01

B051-02



C306-03



DETAIL B051-02

C306-03

Separate control panel, complete with switch and electrical protections to get B051-01 and B051-02 thermostats to CE safety Directive.



B052

Digital water bath

This bath is fully double walled stainless steel made with wool insulation. The specimens are held by a shelf spaced from the bottom.

Complete with digital thermostat and electric stirrer "for continuous water recirculation", ensuring a constant and uniform temperature of $60 \pm 1^\circ\text{C}$ or $37,8 \pm 1^\circ\text{C}$ as prescribed by the Standards.

The bath can hold up to 20 Marshall specimens

Capacity: 60 litres

Temperature range: from ambient to 95°C

The bath is equipped of a dual safety thermostat to prevent accidental over-heatings.

Inside dimensions: 700x550x165 mm

Outside dimensions: 900x640x340 mm

Power supply: 230V 1 ph 50/60 Hz 1500 W

Weight: 28 kg



B052+B052-10



B052-01

B052-01

Digital water bath

Identical to mod. B052 but:

Inside dimensions: 430x420x160 mm

Outside dimensions: 620x500x330 mm

The bath can hold up to 9 Marshall specimens

Capacity: 30 litres

Power Supply: 230V 1 ph 50/60 Hz 1200 W

Weight: 15 kg



B052-02

B052-02

Digital water bath with cooling device

Similar to mod. B052 but equipped with cooling unit housed under the bath for controlling water temperatures where the ambient temperature is quite higher.

Temperature range from: $+3$ to $+95^\circ\text{C}$, accuracy: $\pm 1^\circ\text{C}$.

The bath can hold up to 12 Marshall specimens

Capacity: 45 litres

Inside dimensions: 635x360x205 mm

Outside dimensions: 800x430x1000 mm

Power supply: 230V 1 ph 50/60 Hz 1650 W

Weight: 60 kg

ACCESSORY FOR MOD. B051 ÷ B052-02

B052-10 Alcohol control thermometer $0-100^\circ\text{C}$ subd. 1°C

section B



I 25

MATTEST



B053-10

Cohesion tester

STANDARDS: EN 12274-4 / ASTM D3910

This instrument is used for cohesion tests on the mix, and to determine the proper consistency or mix design for a slurry seal mixture. The pneumatic cylinder incorporated into the unit applies a pressure to the sample. A hand torque tester supplied with the cohesion unit, measures the torquing strength by determining the complete solidification of the mix.

Supplied complete with torque wrench, 5 moulds dia. 60 x h 6 mm, 5 moulds dia. 60 x h 10 mm, accessories, spare parts.

To perform the test an air pressure source is needed.

Dimensions: 400x250x300 mm approx.

Weight: 20 kg approx

ACCESSORIES:

V206 AIR COMPRESSOR. 230V, 50Hz, 1ph.

SQUARE MOULD with 4 holes to prepare the sample:

B053-12 MOULD 140x140x6,3 mm

B053-13 " 140x140x10 mm

B053-14 " 200x200x13 mm

B053-15 " 200x200x19 mm

SPARE PARTS:

B053-16 MOULD dia. 60 x h 6 mm (5 pieces)

B053-17 MOULD dia. 60 x h 10 mm (5 pieces)

B053

"Vialit" - binder adhesion test

STANDARDS: EN 12272-3 / NF P98-274-1

Used to evaluate the global adhesion and the active adhesion between bitumen and aggregates for road surfaces realization. The equipment is formed by:

Six metal test plates

Steel ball weighing 512 g

Metallic base with three vertical support points and metallic rod 500 mm high

Metallic hand operated roller, rubber lined with lead shots ballast.

Weight: 40 kg approx.

SPARE:

B053-01

Metal test plate.



B053

S148

Consistency determination

STANDARDS: EN 12274-3, EN 1097-6

SAND ABSORPTION CONE AND TAMPER, also used for the determination of the absorption and specific gravity of fine aggregates.

Weight: 600 g approx.



B053-10

B053-20

Planetary abrasion tester

DETERMINATION OF WEARING

STANDARDS: EN 12274-5 / ASTM D3910

The unit consists of a planetary mixer in which container the slurry mixture is placed and a weighted special headed rubber hose applies an abrasion action.

Power supply: 230V 1ph 50Hz

Dimensions: 340x460x500 mm approx.

Weight: 40 kg approx.



B053-20

B053-05

Rate of spread device

STANDARDS: EN 12272-1 / BS 598:108

This apparatus is used for determining the rate of spread of coated chippings on the road surface.

The device consists of a 300 mm square tray, lifted by 4 chains which are fixed on a spring balance.

The rate of spread is directly measured in kg/m²

Weight: 1500 g approx.



S148



B053-05

A113
SKID RESISTANCE AND FRICTION TESTER

MEASUREMENT OF SKID RESISTANCE OF AN ASPHALT SURFACE

STANDARDS: EN 13036-4 / EN 1097-8 / ASTM E303 (see note)

The apparatus is suitable for both site and laboratory applications to perform two types of tests:

- For measuring pavement (road asphalt) surface frictional and skid resistance properties.
- For polished stone value tests on aggregates (curved specimens) from accelerated polishing tests.

The skid tester is also suitable to perform tests on:

- Natural stones conforming to EN 1341, 1342.
- Concrete block pavers conforming to EN 1338.

The tester measures the energy loss when a rubber slider edge is propelled over the surface under test.

The slider lifting device is incorporated in the pendulum base assuring accurate adjustment operations. The height adjusting system is simple and reliable.

The pointer, made from light alloy, has extremely low frictions granting high precision results.

The release mechanism of the pendulum arm has an original solution reducing the friction to minimum for better accuracy.

The skid tester is supplied complete with:

- Additional incorporated scale for tests on Polished Stone Value specimens.
- Rule, plexiglass made, for sliding length verification.
- Thermometer range -10 to +110°C. for surface temperature measurement.
- Stool, wash bottle, bristle, tool set for machine use.
- Carrying case.
- Calibration Certificate conforming to EN 1097-8.

The tester is supplied "WITHOUT" rubber sliders that have to be ordered separately (see accessories).

Case dimensions: 730 x 730 x 330 mm. Weight: 32 kg

NOTE: The tester is supplied calibrated to meet EN and BS Specifications. On request Matest can supply the skid tester calibrated to meet ASTM E303 Specifications.



A113

A113-01
Skid Tester - ASTM E303

As above, but calibrated to meet ASTM E303 Specifications.

ACCESSORIES:

A110-03 Mounted rubber slider for site use (pavement surface), complete with conformity certificate.

A110-01 Mounted rubber slider for Polished Stone Value tests (laboratory), complete with conformity certificate.

A110-11 Metal base plate for Polished Stone Value tests in laboratory, and for tests on natural stones and concrete block pavers. Supplied "without" specimen clamping devices, to be ordered separately.

A110-12 Clamping device for Polished Stone Value tests in Laboratory.

A110-13 Clamping device for tests on natural stones (EN 1341, 1342); for concrete block pavers (EN 1338) and skidding tests on wooden floor (EN 1339).

A110-20 Pink lapping film (10 sheets) for Skid Calibration.

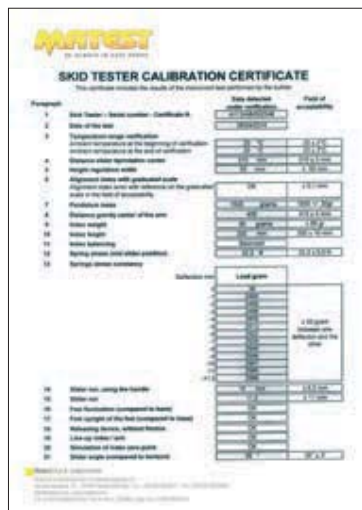

A113
in carrying case

Calibration certificate
to EN 1097-8

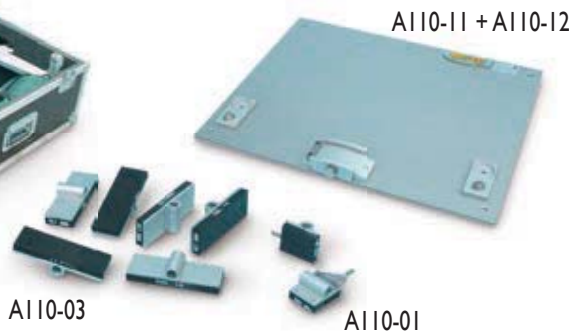

A110-03

A110-01

A110-11 + A110-12



B056 KIT

Standard dial penetrometer

STANDARDS: EN 1426 / ASTM D5 / BS 2000 / NFT66-004 / AASHTO T49
UNI 4162 / UNE 7013 / NLT 124 / CNR N° 24

Used to determine the consistency of a bituminous sample under fixed conditions of load, time and temperature. The penetration is expressed in distance of tenths of millimeters vertically penetrated by a standard needle. The standard penetrometer is ruggedly constructed, with an aluminium base table with levelling screws, plated vertical rod, "micrometric vertical adjustment device".

The slider is brass made with free fall.

The dial, graduated in 360° (division 0,1 mm.), has diameter of 150 mm.

The penetrometer is supplied with stop and release push button, automatic zero set, micrometer adjustment, set of weights 50 and 100 g, penetration needle, brass sample cups dia. 55x35 mm and 70x45 mm.

Dimensions: 220x170x410 mm.

Weight: 11 kg

B057 KIT

Automatic dial penetrometer

Basically structured as mod. B056 KIT but having a magnetic controller device with electronic digital programmable timer that automatically releases the plunger head and ensures free falling of the needle during the 5-seconds test.

Power supply: 230 V 1 ph 50/60 Hz 200 W

Dimensions: 220x280x410 mm.

Weight: 15 kg

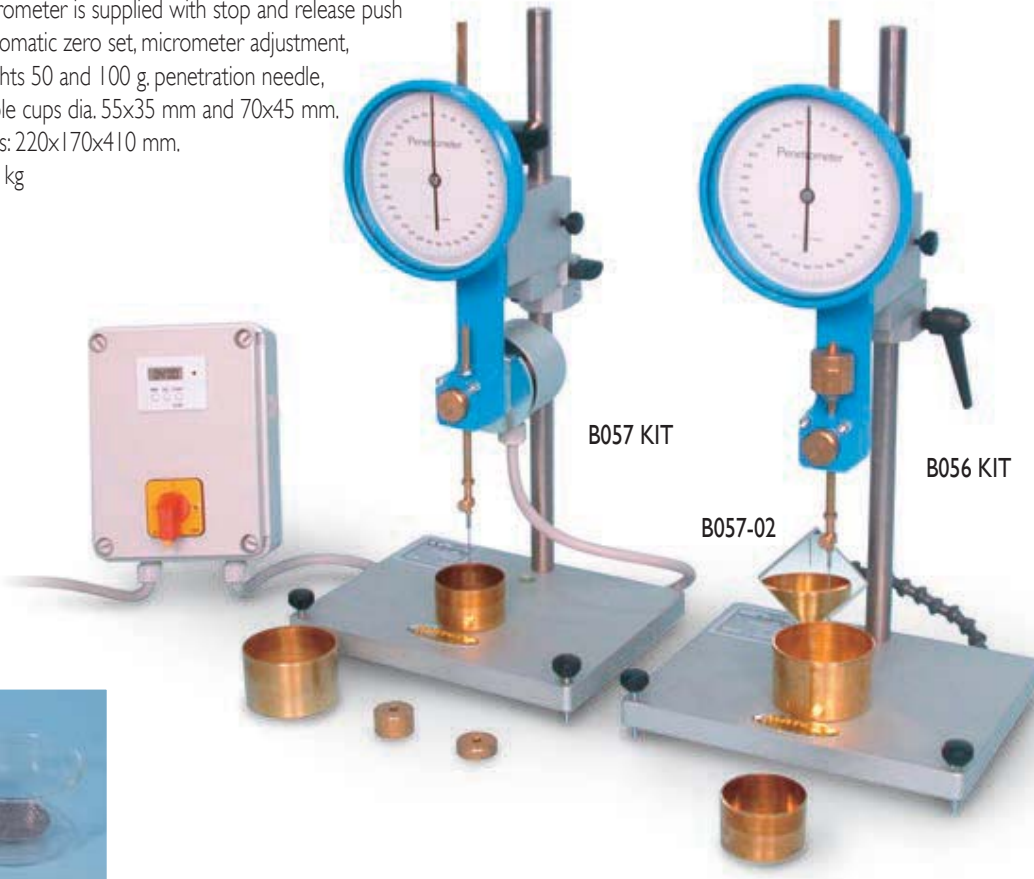

ACCESSORIES:

B057-02 MIRROR, for an easier setting of the needle.

B057-03 TRANSFER DISH, made from glass, with support.

B057-06 PENETRATION NEEDLE HARDENED STEEL, supplied with UKAS Verification Certificate. Weight: 2,5 ± 0,05 g

B057-07 PENETRATION NEEDLE HARDENED STEEL
Each needle is individually verified with engraved serial number, and perfectly meets EN 1426 Specification.
Weight: 2,5 ± 0,05 g

B057-08 TERMOMETER, IP 38C
Range: +23°C to +26°C. - Grad. 0,1°C

B089 TERMOMETER, EN,
Range: +19°C to +27°C.
Grad. 0,1°C - ASTM 17C



SPARES:

B057-01 PENETRATION NEEDLE, NOT HARDENED.
Comparable to EN Spec. Weight: 2,5 ± 0,05 g

B057-04 50 g weight.

B057-05 100 g weight.

V122-05 SAMPLE CUP, brass made, dia. 55x35 mm

V122-06 SAMPLE CUP, brass made, dia. 70x45 mm

B056-01 KIT
Standard digital penetrometer

STANDARDS: EN 1426 / ASTM D5 / BS 2000 / NFT66-004 / AASHTOT49
 UNI 4162 / UNE 7013 / NLT 124 / CNR N° 24

Used to determine the consistency of a bituminous sample under fixed conditions of load, time and temperature. The penetration is expressed in distance of tenths of millimeters vertically penetrated by a standard needle. The standard penetrometer is ruggedly constructed, with an aluminium base table with levelling screws, plated vertical rod, "micrometric vertical adjustment device".

The slider is brass made with free fall.

The digital readout of the penetration values has readings in mm and inch, with 0,01 mm resolution, LCD 5 digits display, with zero set in any position.

Power: 1,5V battery;

The penetrometer is supplied with stop and release push button, automatic zero set, micrometer adjustment, set of weights 50 and 100 g, penetration needle, brass sample cups dia. 55x35 mm and 70x45 mm.

Dimensions: 220x170x410 mm.

Weight: 11 kg

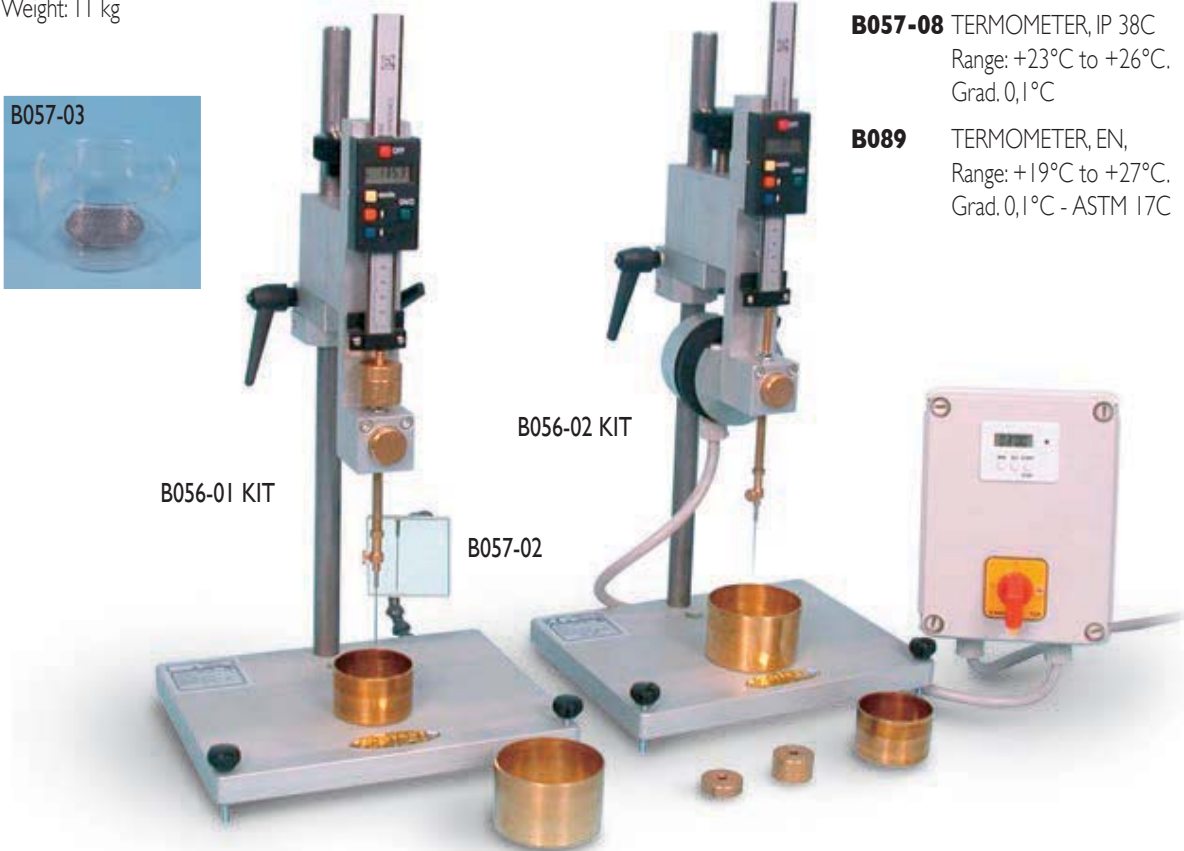

B056-02 KIT
Automatic digital penetrometer

Basically structured as mod. B056-01 KIT but having a magnetic controller device with electronic digital programmable timer that automatically releases the plunger head and ensures free falling of the needle during the 5-seconds test.

Power supply: 230V 1 ph 50/60 Hz 200 W

Dimensions: 220x280x410 mm. Weight: 15 kg

ACCESSORIES:

B057-02 MIRROR, for an easier setting of the needle.

B057-03 TRANSFER DISH, made from glass, with support.

B057-06 PENETRATION NEEDLE HARDENED STEEL, supplied with UKAS Verification Certificate. Weight: 2,5 ± 0,05 g

B057-07 PENETRATION NEEDLE HARDENED STEEL, each needle is individually verified with engraved serial number, and perfectly meets EN 1426 Specification. Weight: 2,5 ± 0,05 g

B057-08 TERMOMETER, IP 38C
 Range: +23°C to +26°C.
 Grad. 0,1°C

B089 TERMOMETER, EN,
 Range: +19°C to +27°C.
 Grad. 0,1°C - ASTM 17C



SPARES:

B057-01 PENETRATION NEEDLE, NOT HARDENED.
 Comparable to EN Spec. Weight: 2,5 ± 0,05 g

B057-04 50 g weight.

B057-05 100 g weight.

V122-05 SAMPLE CUP, brass made, dia. 55x35 mm

V122-06 SAMPLE CUP, brass made, dia. 70x45 mm





B058
Thermostatically controlled water bath for penetrometer

Provides water at the required temperature of $25 \pm 0,1^{\circ}\text{C}$. The unit consists of a stainless steel water bath 10 litres capacity with wool insulation, immersion heater with digital thermostat, motor pump with connections, cooling coil device, current water operated, to maintain a constant temperature of the bath when room temperature is slightly higher. The bituminous sample is immersed into the water bath, and placed on the penetrometer only at the time of the test, by eventually using the transfer dish (accessory mod. B057-03).
Power supply: 230V 1 ph 50/60 Hz 350 W
Dimensions: 375x335x420 mm
Weight: 12 kg



B016
Air bath

Used for softening bitumen before performing a range of tests including ductility, flash point, penetration, loss on heating. Inner vessel, stainless steel made, has 600 g. capacity. Complete with thermoregulator; pilot lamp.
Power supply: 230V 1 ph 50-60 Hz 500 W
Dimensions: 140x140x350 mm
Weight: 5 kg

B059 KIT
Automatic digital penetrometer

STANDARDS: EN 1426 / ASTM D5 / BS 2000 / NFT66-004
NLT 124 / AASHTO T49 / UNI 4162 / UNE 7013
CNR N° 24

Digital measure of the penetration values.
Measuring range: 50 mm, sens. 0,01 mm
Motorized approach of the needle, driven by camera (needle diameter = 5 mm on the monitor).
Electric control of the approach.
Electromechanical release and locking device of the needle.
Motorized return of the needle.
USB port for printer or PC connection.
Supplied complete with needle, weights, sample cups.
Power supply: 230V 1 ph 50 Hz
Dimensions: 260 x 320 x 540 mm
Weight : 23 kg



B059 KIT



B060

B060
Bacon sampler

STANDARDS: EN 58 / CNR N° 81, N° 98
ASTM D140 / AASHTO T40
Used to obtain asphalt or oil samples from various levels within a storage tank by the "thief" method. Made from brass.
Capacity 237 ml
Dimensions: dia. 50x250 mm. Weight: 2 kg

ACCESSORY:

B058-01
WATER BATH DISH with incorporated thermostatic coil, to be connected to the bath mod. B058. It keeps the temperature of the bitumen sample directly on the penetrometer, by avoiding to transfer it.



B058 detail

B066N KIT
Rolling Thin-Film Oven
ASTM / EN

EFFECT OF HEAT AND AIR ON A MOVING FILM OF ASPHALT. RTFOT METHOD
 STANDARDS: EN 12607-1 / ASTM D2872-12
 AASHTO T240

Utilized to measure the air and heat effect on a moving film of asphaltic semisolid materials. External frame and internal chamber are stainless steel made with insulated fiberglass intermediate chamber.

Provided of large glass door for inspections. The oven must be connected to a suitable air pressure supply.

Supplied complete with precision digital thermostat to maintain 163°C temperature, control thermometer ASTM 13C, ventilation device, set of eight glass containers dia. 64x140 mm.

The oven is equipped of a dual safety thermostat to prevent accidental over-heatings.

Power supply: 230V 1 ph 50 Hz 1700 W

Dimensions: 620x620x910 mm

Weight: 55 kg



B066N KIT

section B



131

SPARES:

B066-02 Glass container dia. 64x140 mm

B064-03 Thermometer, ASTM 13C. Range: +155°C. to +170°C. div. 0,5°C.

B064 KIT
Asphalt oven with rotating shelf.

THIN FILM AND LOSS ON HEATING DETERMINATION. TFOT METHOD

STANDARDS: EN 12607-2, EN 13303 / CNR N° 50 / ASTM D6, D1754 / AASHTO T47, T179 / BS 2000 / UNE 7110 / NF T66-011

Internal chamber and external frame all made from stainless steel, double wall insulation with fiberglass, double door. Temperature control by digital thermoregulator. The oven is equipped of a dual safety thermostat to prevent accidental over-heatings. The plate rotates at 5-6 rpm. Supplied complete with glass control thermometer ASTM 13C, +155 to +170°C subd 0.5°C.

The oven is supplied "without rotating shelf and accessories", that must be ordered separately.

Power supply: 230V 1 ph 50 Hz 1500 W

Internal dimensions: 330x330x330 mm

Outside dimensions: 460x450x700 mm

Weight: 40 kg

THE OVEN MOD. B064 CAN BE EQUIPPED IN TWO VERSIONS, WITH THE FOLLOWING ACCESSORIES:

B064-01 KIT

Rotating shelf complete with 9 containers dia. 55x35 mm for the "Determination of Loss on Heating" to: EN 13303 / ASTM D 6 / BS 2000 / NFT066-011 / AASHTO T47 / CNR N° 50 / NFT066-011 - AASHTO T47 Standards.

B064-02

Rotating shelf, complete with 2 containers dia. 140x9,5 mm for the "Determination of Thin Film" to: EN 12607-2 / ASTM D1754 / AASHTO T149 / UNE 7110 Standards.

AS ALTERNATIVE:

B064-02 SP

Rotating shelf, same as B064-02, but complete with 4 containers



B064 KIT + B064-01 KIT



B064-02

B064-01 KIT

SPARES:

V122-05 Brass container dia. 55x35 mm

B064-04 Stainless steel container dia. 140x9,5 mm

MATTEST



B054

Ductilometer

STANDARDS: EN 13589 / EN 13398

ASTM D113, D6084 / AASHTO T51

NFT66-006 / NLT 126 / UNE 7093 / CNR N° 44

Used to determine the bituminous ductility, that is to say, the distance to which a briquette of molten bitumen can be extended under controlled conditions, before its breaking. The Ductilometer basically consists of a moving carriage travelling along guide ways. The carriage is driven by an electrical motor, inside a large tank which is fitted with digital thermostat, immersion electric heater, cooling coil for cold water circulation and pump unit. This model works in an automatic way at a speed of 50 mm/min. and its max. stroke is 1500 mm. The tank and the external frame are all made from stainless steel with fibreglass insulation. Water bath temperature is maintained constant at $25^{\circ}\text{C} \pm 0,5^{\circ}\text{C}$. by a digital thermoregulator. The unit is equipped of a dual safety thermostat to prevent accidental over-temperatures.

Max. traction force: 300 N, accuracy: $\pm 0,1$ N

The ductilometer can accept up to 3 specimens simultaneously.

Supplied complete "except" for the briquette mould and base plate that must be ordered separately (see accessories).

Power supply: 230V 1 ph 50 Hz 1000 W

Dimensions: 2140x350x400 mm

Weight: 95 kg

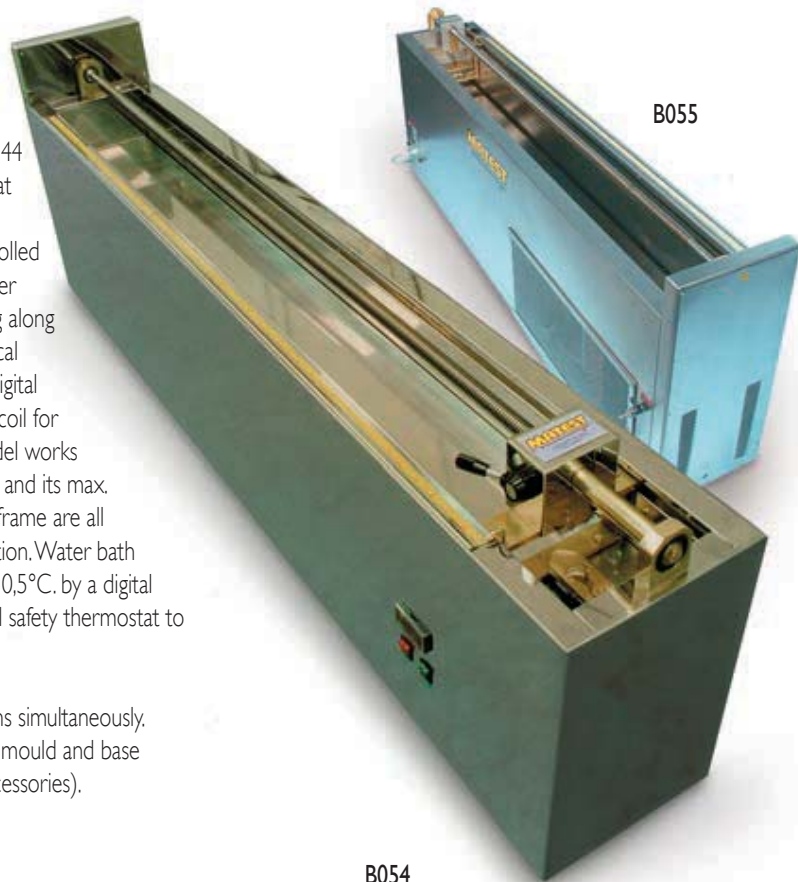

B055

Ductilometer with cooling system

Same as for mod. B054 but equipped with incorporated refrigerating unit for tests with water temperature from $+5^{\circ}$ to $+25^{\circ}\text{C}$.

Dimensions: 2140x350x750 mm. Weight: 130 kg

ACCESSORIES:

B054-01

DUCTILITY BRIQUETTE MOULD - STANDARDS: ASTM, AASHTO

Used to prepare the specimen, it is brass made, accurately machined. Supplied without base plate. Weight: 300 g

B054-03

DUCTILITY BRIQUETTE MOULD - STANDARD: EN 13398

Used to prepare the specimen, it is brass made, accurately machined. Supplied without base plate. Weight: 300 g

B054-04

DUCTILITY BRIQUETTE MOULD - STANDARD: EN 13589

Used to prepare the specimen, it is brass made, accurately machined. Supplied without base plate. Weight: 300 g

B054-02 BASE PLATE for ductility briquette mould.



B077 KIT

Fraass apparatus

BREAKING POINT

STANDARD: EN 12593



This apparatus is used to determine the breaking point of semisolid and solid bitumes. It consists of a flexure device with two concentric sliding resin tubes, jaws for the test specimen, flexure system with handle, cooling device with three containers, plate in special harmonic steel, thermometer IP 42C. Weight: 4 kg

SPARES:

B077-01

Plate (spring) in special armonic steel

B077-02

Thermometer IP 42C

B055-10

Ductilometer with data acquisition

Technical, mechanical and Standards specifications: same to mod. B054, but upgraded with:

- Cyber-plus 8 evolution data acquisition and processing system, "colour touch screen display" 1/4VGA, 24 bit resolution. It automatically performs data acquisition and processing. Directly connected to printer (accessory) via USB it prints the test certificate. Equipped with slots for external pendrive or SD card infinite memory support with direct connection to PC. Hardware details: see pag. 24
- Software UTM NET to unload and visualize test data to PC.
- One electric load cell 50 N capacity complete with installation and calibration. (Possibility to install later on up to 3 cells directly by the end user).

Supplied "without" briquette mould and base (see accessories).

ACCESSORIES:

B055-15

LOAD CELL electric, 50 N capacity, complete with installation and calibration (possibility to install up to 3 cells).

B055-16

REFRIGERATING UNIT, incorporated into the machine, for tests with water temperature from +5°C to +25°C (not possible to fix later on).

C128

LASER PRINTER, bench model, for graphics and certificates with direct connection via USB

Ductility moulds and base plate: see pag. 132

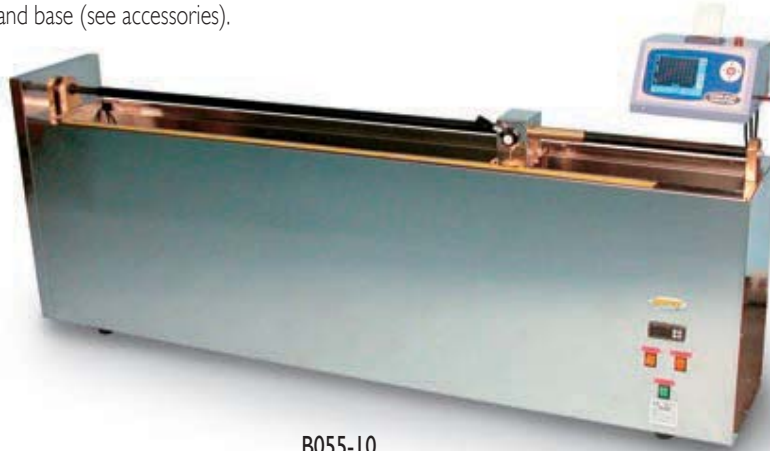

B055-10



B055-20N

B055-20N

Ductilometer with data acquisition "high performance"

STANDARDS: EN 13589, 13703, 13398 / ASTM D113, D6084 AASHTO T51

Developed and manufactured for ductility tests and for research purposes.

- Stepper motor providing a variable speed range from 1 to 400 mm/min with digital displacement measuring system.
- Up to 3 samples can be tested simultaneously.
- One electric high capacity load cell 500 N (possibility to install later on up to 3 cells directly by the end user).
- Automatic positioning of start test
- Visualization of the elongation in mm
- Visualization of the load/elongation chart
- Max elongation recording before breaking failure
- Absorbed energy elaboration
- Temperature setting and visualization of the test execution with continuous recording during the test
- Test certificate print-out (USB connector or local printer)
- Cyber-plus 8 evolution data acquisition and processing system "colour touch screen display" (technical details: pag. 24).

- Software UTM2 to unload and visualize test data to PC.
- Glass upper cover:

Supplied "without" briquette mould and base (see accessories).

Power supply: 230V 1ph 50/60Hz 1000W

Dimensions: 2140x400x450mm. Weight: 110 kg approx.

ACCESSORIES:

B055-25

LOAD CELL electric, 500 N capacity, complete with installation and calibration (possibility to install up to 3 cells).

B055-26 REFRIGERATING UNIT, incorporated into the machine, for tests with water temperature from +5°C to +25°C. (Not possible to fix later on).

C128

LASER PRINTER, bench model, for graphics and certificates with direct connection via USB.

Ductility moulds and base plate: see pag. 132



Detail: 3 load cells 500 N



B072

Ring and Ball softening point apparatus

STANDARDS: EN 1427 / ASTM D36 / AASHTO T53 / NF T66-008
 Comparable to: BS 2000 / UNI 4161 / DIN 52011 / UNE 7111

The softness of bitumen depends, amongst other factors, on the temperature of the substance, where, as the temperature is raised, the softness of the bitumen increases. The unit consists of a pyrex beaker, brass frame, two tapered rings, two ball centering guides and two balls. Weight 900 gr.

ACCESSORIES:

B072-01 THERMOMETER ASTM 15 C -2 to +80°C subd. 0,2°C

B072-02 THERMOMETER ASTM 16 C +30 to +200°C subd. 0,5°C



134



B072-07

Pouring plate, to pour the bituminous mixture into the brass tapered ring, as requested by EN 1427 Specification.
 Dimensions: 75x50x10 mm



B074

Hot plate, complete with thermoregulator for temperature adjustment.

Power supply: 230V 1 ph 50/60 Hz 1000W
 Weight: 6 kg

ACCESSORY:

B074-01

Electric stirrer, accessory to the hot plate B074 to ensure a more uniform temperature to the bath.

Supplied complete with vertical support and base.
 Power supply: 230V 1 ph 50 Hz 100W
 Weight: 3 kg

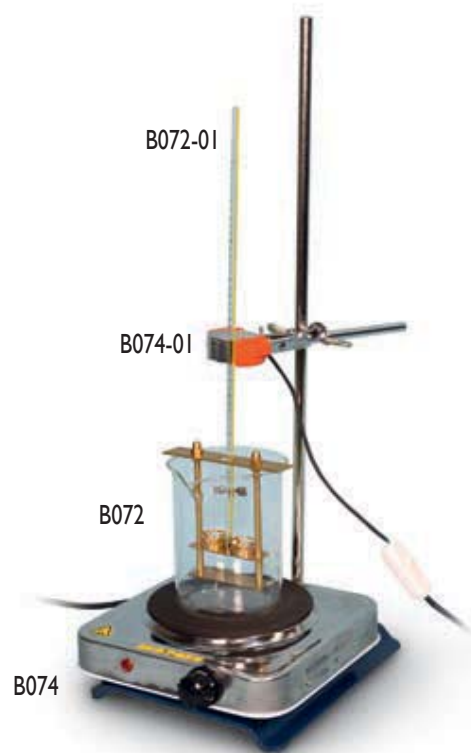

B073-01

Hot plate with magnetic stirrer

Complete with thermoregulator for temperature adjustment and magnetic stirrer with electronic adjustment from 100 to 1200 rpm. Suitable for tests in distilled water with softening point between +30°C. to +80°C.

Alternative version to mod. B074 + B074-01

Power supply: 230V 1 ph 50-60Hz 700W

Weight: 4 kg approx.

B073-02

Hot plate with magnetic stirrer

Same to mod. B073-01, but with more powerful electric heating resistance, suitable "also" for tests in glycerine with softening point over +80°C. up to +150°C.

Power supply:
 230V 1 ph 50-60Hz 700W

SPARES for B072:

B072-03 Steel ball dia. 9,5 mm

B072-04 Brass tapered ring

B072-05 Ball centering guide

B072-06 Pyrex beaker



B070N1

SOFTMATIC

Automatic Digital Ring and Ball apparatus "TOUCH-SCREEN"

STANDARDS: EN 1427 / ASTM D36 / AASHTO T53 / NF T66-008;
comparable to: BS 2000 / DIN 52011 / UNE 7111 / UNI 4161 / CNR N.35

This "high technology" digital microprocessor tester, designed and manufactured by Matest, automatically determines the softening point of asphalts and pitches.

Two laser sensors detect the balls fall determining the softening point.

The bath temperature is measured by an electronic system maintaining the gradient (5°C./min) as specified by the Standards.

Real time visualization of the Temperature(°C)-Time(sec) graph along the entire test.

A magnetic stirrer with electronic speed adjustment from 0 to 160 rpm also ensures an uniform temperature in the vessel during the test execution.

The touch-screen graphical interface allows an easy set up of the parameters and the immediate execution of the test.

High resolution color display, 1/4 VGA, offers all the functions of a PC for the management and analysis of data, test results, and graphs.

Two test parameters can be selected by the microprocessor menu:
- test on boiled distilled water for softening point from 30 to 80°C.
- test on glycerol for softening point from 80 up to 150°C.

Language selection: English, French, Spanish, German, Italian, Polish, Russian, Greek, Portuguese, Dutch.

Functions of: clock calendar; test number; user/customer name, general notes, start/end of the test.

Real time visualisation of the bath temperature, test progress, rpm of the stirrer.

Unlimited memory, with possibility to save data onto an external memory (USB pendrive, SD card) and then edit them through an Excel spreadsheet.

The tester is basically composed by:

- Ceramic-glass heating plate with automatic cut off at the end of the test cycle.
- Motherboard with microprocessor, which controls: heater/stirrer; temperature probe, laser sensors, pre-heating phase of the plate, and memorizes all the test parameters.
- Steel balls centering device.

Power supply: 230V 1ph 50/60Hz 700W
Dimensions: 500x350x550 mm
Weight: 20 kg approx.

ACCESSORY:

B070-11

RODS WITH SPHERICAL ENDS (set of 2 pieces) for checking and calibration of the instrument.

SPARE PARTS for B070N:

B072-03 Steel ball 9,5 mm diameter

B070-15 Brass tapered ring, chromed

Temperature-Time graph

B070-16 Brass centering guide, chromed

B070-17 Pyrex beaker



B070N1

section B



I 35

- Main Functions:**
- Touch-Screen display like a normal PC
 - Unlimited memory
 - Multilanguage selection
 - Microprocessor friendly-driven menu to control all the test phases
 - Top quality components: laser sensors, electronic magnetic stirrer, ceramic-glass heating plate
 - Fully automatic

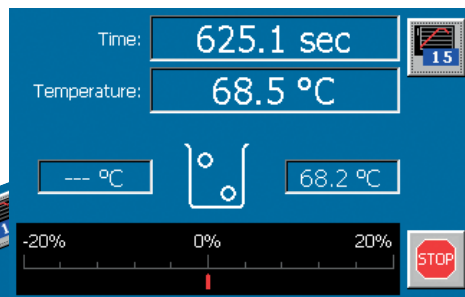

Test execution

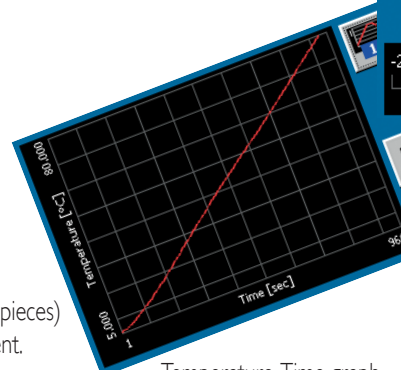

MATEST



B075

Water in bitumen emulsions

STANDARDS: EN 1428, 12847 / ASTM D244 / NFT66-023, T66-113

Used to determine the water in petroleum products or bituminous materials, by distilling them with a water immiscible, volatile solvent. The equipment comprises:

- Glass balloon 500 ml
- Glass receiver 25 ml capacity with 0,1 ml grad.
- Glass reflux condenser
- Electric heater with thermoregulator; clamps.
- Power supply: 230V 1ph 50-60Hz 500W
- Weight: 8 kg approx.



B075

B076

Water in bituminous materials (Dean-Stark)

STANDARDS: ASTM D95, D244
AASHTO T55, T59 / IP 74-77
CNR No. 101 / NLT 123

Identical to mod. B075 except for the receiver having 10 ml capacity.

Bituminous emulsions: Residue on sieving

STANDARD: EN 1429

- B076-21** Sieve, stainless steel, 75 mm dia., 0,5 mm opening
- B076-22** Sieve, stainless steel, 75 mm dia., 0,16 mm opening
- B076-24** Pan and Cover; stainless steel, 75 mm dia.



Bituminous emulsions: Mixing stability with cement

STANDARD: EN 12848

- B076-23** Sieve, stainless steel, 75 mm dia., 2 mm opening
- B076-22** Sieve, stainless steel, 75 mm dia., 0,16 mm opening
- B076-24** Pan and Cover; stainless steel, 75 mm dia.

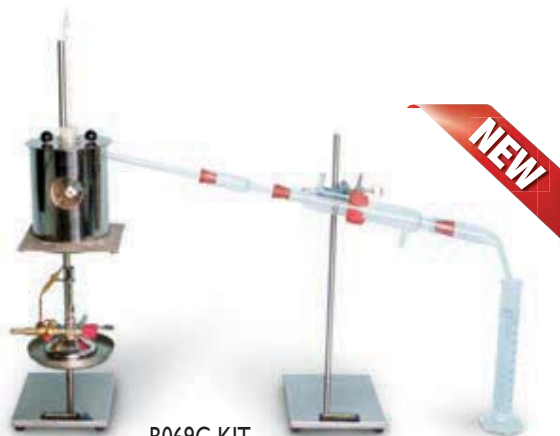

B069G KIT

A122-10

Tilt Test

The instrument measures the roughness coefficient of a joint. The unit is also designed to test the possible fluage tendency of bituminous mixtures covering a slope of a dam subject to high sun radiations. The fluage tendency is the permanent viscous deformation of a material. The apparatus consists of an inclined adjustable plane on which the sample is placed.

- Inclination angle: 0 - 50°
- Max. sample diameter: 100 mm

The plane is slowly tilted until sliding of the upper surface of specimen on the lower one occurs. The roughness index can be evaluated from the measured inclination angle.

Dimensions: 270x175x265 mm. Weight : 5 kg approx.



A122-10

Distillation of cut-back asphalts

STANDARDS: ASTM D402 / AASHTO T78 / NFT66-003
UNE 7112, 7072

Used to measure the amount of the most volatile constituents in cut-back asphaltic products.

MODELS:

B069 KIT

Distillation of cut-back asphalts, electric

The apparatus consists of: "electric heater with thermoregulator", distillation flask, condenser tube, adapter, shield, receiver; supports, graduated cylinder; thermometer ASTM 8C -2 to +400°C, subd. 1°C

Power supply: 230V 1ph 50/60Hz 750W
Weight: 12 kg approx.



B069 KIT

B069G KIT

Distillation of cut-back asphalts, gas operated

The apparatus consists of: BUNSEN BURNER, universal, with air control. Complete with gas-stop valve controlled by a flame sensor and maximum thermostat with reset button, distillation flask, condenser tube, adapter, shield, receiver supports, graduated cylinder; thermometer ASTM 8C -2 to +400°C, subd. 1°C

It can be sold in CE markets, but not usable in closed spaces.

Weight: 8 kg approx..

B069-11 Spare thermometer ASTM 8C

B063-10

Particle charge tester

DETERMINATION OF PARTICLE POLARITY OF BITUMEN EMULSIONS

STANDARDS: EN 1430 / ASTM D244 / CNR N. 99

This apparatus is used to identify the particle charge of bitumen emulsions.

The equipment comprises:

- Milliammeter scale up to 10 mA on support base
- Variable resistor
- Two stainless steel electrodes
- Insulating device
- Beaker 250 ml capacity to EN spec.
- Glass rod

Power supply: 250V 1ph 50/60Hz

Dimensions: 200x200x600mm

Weight: 3 kg approx.



ACCESSORY:

B063-11

BEAKER 500 ml capacity to ASTM spec.

B072-20

Wilhelmi softening point apparatus

STANDARDS: EN 1871 / DIN 1996-15

Used for determining the softening point of bituminous materials for road construction, according to Wilhelmi method.

The softening point is the temperature where a layer of thermoplastic material has a deformation given by a steel sphere weighting 13,9 g. The apparatus comprises a ring divided in two halves on a metal support frame, glass beaker, steel ball 15 mm dia.

Weight: 2 kg approx.

B072-20 + B072-02



ACCESSORIES for B072-20:

B072-02

THERMOMETER, ASTM 16C, scale +30°C. +200°C., subd. 0,5°C.

B073-02

ELECTRIC HEATER WITH MAGNETIC STIRRER, suitable for still water and glycerine tests, with softening point up to 150°C.

Power supply: 230V 1ph 50/60Hz 1000W

Weight: 4 kg approx.

See pag. 134

B063 KIT

Emulsified asphalt distillation apparatus

STANDARDS: EN 1431 / ASTM D 244 / AASHTO T 59
CNR N° 100

Used for the determination of cut-back asphaltic materials by the distillation test. The set is formed by: aluminium still container; glass connectors including condenser, stands, graduated cylinder; two thermometers ASTM 7C range -2 to +300°C, gas ring burner with gas stop valve controlled by a flame sensor.

It can be sold in CE markets, but not usable in closed spaces.

Weight: 12 kg

SPARE:

B063-01 Thermometer ASTM 7C



B063 KIT

B063-05

Storage stability of asphalt emulsions

STANDARD: NF T66-022

This apparatus is used for the determination of the storage stability of emulsions by decantation. It consists of a 12V current stabilized

source, cylindrical electrode, base with holder, stainless steel vessel 500 ml capacity, watch glass.

Power supply: 230V 1ph 50/60Hz

Dimensions: 200x200x500 mm

Weight: 5 kg approx.



B063-05





B065

Rotary Evaporation Apparatus

BITUMINOUS BINDERS. DETERMINATION OF THE RESISTANCE OF HARDENING. ROTATING FLASK TEST: RFT METHOD. STANDARD: EN 12607-3

This unit is used to evaluate the hardening effect of a treated bituminous binder sample. The test is performed by introducing 100 g of bituminous binder into the rotating flask. The sample is heated at 165°C and ambient temperature air is blown into the flask containing the binder hardening the same. The hardening effect is evaluated by penetration, viscosity and softening point tests.

The Rotary Evaporation Apparatus is essentially composed by: distillation flask 1000 ml capacity rotated by a speed motor at an adjustable rate of 20 to 280 rpm, condenser, solvent recovery flask, heated oil bath.

The angle of the rotary/distillation flask is 15°

The instrument is supplied complete with glass tubing with three way valve and transparent flexible hose for solution intake.

The Rotatory Apparatus requires a vacuum pump and a vacuum regulating system (see accessories at pag. 76).

Power supply: 230V 1ph 50Hz. Weight: 27 kg approx.



B065

B075-05

Determination of solubility of bituminous binders

STANDARDS: EN 12592 / ASTM D2042 / IP 47

The set comprises :

Gooch crucible complete with funnel and rubber ring

Filter flask 500 ml capacity with rubber stopper

Whatman filter fibreglass discs, 25 mm dia.

(pack of 100)

Weight: 1000 g approx.



B075-05

B075-01

Graduated cylinder with side tubes and stopper

BITUMEN EMULSIONS: DETERMINATION OF SETTLING TENDENCY

STANDARDS: EN 12847 / IP 485

The cylinder has 600 ml capacity, it is marked at 500 ml and two side tubes are foreseen.

Weight: 800 g approx.

To perform this test the water in petroleum emulsion equipment mod.B075 ia also required. See pag. 136



B075-01

B075-08

B075-08

Glass tube with glass filter

BITUMEN EMULSIONS: DETERMINATION OF PENETRATION POWER

STANDARDS: EN 12849 / IP 487

The glass tube has 41,5 mm inside dia. by 115 mm height, and a fused-on glass filter with holes size between 0,160 and 0,250 mm is fitted. Weight: 300 g approx.

B090

Breaking value of cationic bitumen emulsions. Mineral filler method

STANDARDS: EN 13075-1 / IP 494

Equipment for the determination of the breaking value of cationic emulsions, (manual version) comprising:

Filler feeding pan, complete with support base and clamp, nickel spatula, two round porcelain dishes.

Weight: 2 kg approx.

ACCESSORIES FOR AUTOMATIC VERSION:

B090-10 Electric stirrer having 260 rpm., 230V 50/60Hz, 1ph

S157-06 Support base for stirrer.

B090-11 Propeller for electric stirrer.

B090-12 Metallic container, 500 ml capacity.

B090-20 Reference filler, 50 kg (two bags of 25 kg).

B090-21 Reference filler original Sikasoil recommended by EN Standard. Bag of 50 kg.



B090



B090-10

B090-11

B090-12

**B080
Engler digital viscometer**

STANDARDS: ASTM D 940, D 1665 / AASHTO T54 / BS 2000
NFT66-020 / CNR N° 102

Used to compare the specific viscosity of road-oils and tars to the viscosity of water. It consists of a water bath complete with digital precision thermoregulator, electric stirrer, cooling device, Engler flask. The viscometer is equipped of a dual safety thermostat to prevent accidental over-temperatures.
Power supply: 230V 1 ph 50 Hz 300W
Dimensions: 265x270x550 mm.
Weight: 12 kg



B080+B082-01

**B081
Engler digital viscometer “Two elements”**

Basically structured as mod. B080 but having “Two elements”, electrically operated, supplied complete. Weight: 20 kg

ACCESSORIES for Engler:

B082-01 THERMOMETER ASTM 23 C range +18 +28°C
subd. 0,2°C

B082-02 THERMOMETER ASTM 24 C range +39 +54°C
subd. 0,2°C

B082-03 THERMOMETER ASTM 25 C range +95 +105°C
subd. 0,2°C

B082-04 THERMOMETER NFT66 -020 range 0-55°C. subd. 0,2°C

B082-06 Kohlrash calibration flask 200 ml capacity

B082-07 Filter screen, ASTM N°50

SPARE:

B082-05 Engler testing flask

B083-01 ÷ B083-10

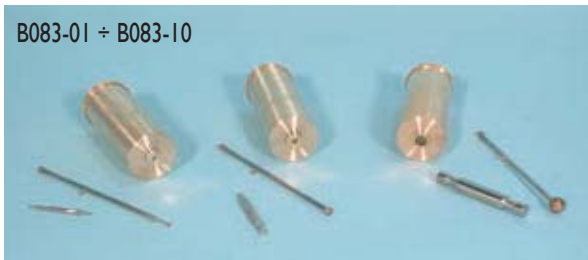

**Efflux Viscometer, “Standard TAR”
(BRTA, Redwood)**

STANDARDS: EN 12846-01, EN 12846-02, EN 13357 / IP 184
NFT66-005 / BS 2000

**B084-01 KIT
Standard TAR (BRTA, Redwood)
Digital Viscometer**

Used to determine the viscosity of cut-back bitumen and road oil. The instrument consists of a stainless steel bath (tank), agitator, rheostat, immersion electric heater with digital thermostat to take the water to the desired temperature, cooling coil for water supply connection. The viscometer is equipped of a dual safety thermostat to prevent accidental over-temperatures.
Supplied with control glass thermometer IP 8C, range 0 - 45°C., subd. 0,2°C., graduated glass cylinder 100ml capacity.
Supplied “without” Cup, Go/not go gauge, ball valve to be ordered separately (see accessories).
Power supply: 230V 50/60Hz 1ph 300W
Dimensions: 265 x 270 x 550 mm. Weight: 12 kg

**B084-02 KIT
“Two Places” Standard TAR
(BRTA, Redwood) Digital Viscometer**

Basically structured as mod. B084-01,
but having “TWO ELEMENTS”

ACCESSORIES for Standard TAR:

Standards: EN, NF, IP

B083-01 Go/not go gauge for dia. 4 mm orifice

B083-02 Cup with orifice dia. 4 mm

B083-03 Ball valve dia. 4 mm

Standards: EN, NF, IP, BS

B083-04 Go/not go gauge for dia. 10 mm orifice

B083-05 Cup with orifice dia. 10 mm

B083-06 Ball valve dia. 10 mm

Standard: EN 12846-02

B083-08 Go/not go gauge for dia. 2 mm orifice

B083-09 Cup with orifice dia. 2 mm

B083-10 Ball valve dia. 2 mm

SPARE PARTS:

B083-07

Thermometer IP 8C,
range 0 - 45°C., subd. 0,2°C.

V101-03

Graduated cylinder, glass,
100ml capacity

B084-01 KIT + accessories



B086 KIT

Cleveland open cap flash and fire point tester

STANDARDS: EN 22592 / ASTM D92 / AASHTO T48
IP 36/67 / UNE 7075 / NFT60-118 / ISO 2592

Used to measure the flash and fire points of lubricated oils and petroleum products.

Complete with brass cup, thermometer IP 28C (ASTM 11C) range -6 +400°C., electric heater with thermoregulator, double line fuse.

Supplied "without" flame gas device to be ordered separately.

Power supply: 230V 1ph 50/60Hz 600W

Weight: 10 kg

"NEEDED" ACCESSORY:

B086-02

FLAME GAS device, complete with gas-stop valve controlled by a flame sensor and maximum thermostat with reset button. It can be sold in CE markets, but not usable in closed spaces.

SPARE:

B086-10 Thermometer IP 28C (ASTM 11C), range -6 +400°C.

B087

Saybolt digital viscometer

STANDARDS: ASTM D88 / AASHTO T72 / UNE 7066, 51021

Used to determine the viscosity of petroleum products at specified temperatures between 70 to 210 °F. Stainless steel made, the Saybolt viscometer is supplied complete with two interchangeable orifices "Furol" and "Universal", oil bath, electric heater with digital thermoregulator; stirrer, cooling coil, viscosity flask. Thermometers, filter funnel, withdrawal tube "are not included" and must be ordered separately. The viscometer is equipped of a dual safety thermostat to prevent accidental over-heatings.

Power supply:

230V 1 ph 50/60 Hz 500W

Dimensions: 270x270x550 mm.

Weight: 12 kg



ACCESSORIES:

| Saybolt Thermometers | Range | Subd. |
|----------------------|-----------------------|-------|
| B089 | ASTM 17C +19 a +27°C | 0,1°C |
| B089-01 | ASTM 18C +34 a +42°C | 0,1°C |
| B089-02 | ASTM 19C +49 a +57°C | 0,1°C |
| B089-03 | ASTM 20C +57 a +65°C | 0,1°C |
| B089-04 | ASTM 21C +79 a +87°C | 0,1°C |
| B089-05 | ASTM 22C +95 a +103°C | 0,1°C |

B087-11 FILTER FUNNEL complete with wire filter ring mesh.

B087-12 WITHDRAWAL TUBE complete.

SPARES:

B089-06 FUROL orifice

B089-07 UNIVERSAL orifice

B089-08 SAYBOLT flask 60 ml capacity



B087-01

Two tube Saybolt viscometer

Basically structured as mod. B087 but with two tubes. Supplied complete except thermometers, filter funnel and withdrawal tube.



Hubbard-Carmick specific gravity

STANDARDS:

EN ISO 3838 / ASTM D70 / NFT66-007

VIII Cylindrical type, 24 ml

VIII-01 Conical type, 25 ml



B092 KIT

Tag closed-cup viscometer. Flash Point

STANDARDS: ASTM D56 / API 509

Suitable for testing volatile flammable flashing between 0 and 175°F (except fuel oils).

Supplied complete with cup, water bath, lid, slide, thermoregulated electronic heating device, thermometer ASTM 9C range -5 to +110°C and thermometer ASTM 57 C range -20 to +50°C.

The tester is equipped of a gas flame feeder.

Power supply: 230V 1 ph 50 Hz 700 W.

Dimensions: 200x300x400 mm approx. Weight: 10 kg



B092 KIT



B094-01 KIT

B093 KIT

Tag open-cup viscometer. Flash Point

STANDARDS: ASTM D1310, D 3143

For the determination of open cup flash points of volatile flammable materials having flash points between 0 and 175 °F

Supplied complete with cup, water bath, thermoregulated electronic heating device, thermometers ASTM 9C -5 to +110°C and ASTM 57C -20 to +50°C.

The tester is equipped of a gas flame feeder.

Power supply:

230V 1 ph 50 Hz 700 W.

Dimensions:

200x300x400 mm approx.

Weight: 10 kg



B093 KIT

B094 KIT

Pensky-Martens digital flash point tester

STANDARDS: EN 22719 / ASTM D93 / AASHTO T73 / IP 34, 35 ISO 2719

Used for the determination of the flash point of petroleum products by the Closed Cup Test, with a Flash Point between 40°C to 360°C.

Supplied complete with stirrer, shield for radiations, cast iron bath, electronic heater with digital thermoregulator two thermometers ASTM 9C -5 + 110°C div. 0,5 C, and ASTM 10C +90 +370°C div. 2°C.

The stirrer allows to perform both "A" and "B" methods

The tester is equipped of a gas flame feeder.

Power supply:

230V 1 ph 50 Hz 700 W.

Weight: 10 kg



B094 KIT

SPARES:

B092-10 Thermometer ASTM 9C

B092-11 Thermometer ASTM 57C

B094-10 Thermometer ASTM 10C

B094-01KIT

Pensky-Martens flash point tester

Similar to mod. B094KIT, but with "electric" thermoregulator (not digital) and the stirrer performs "only" method "A"

B085-07

DSR - Dynamic Shear Rheometer

STANDARDS: ASTM D7145, ASTM D7405 / AASHTOT315

The DSR is a dynamic shear rheometer system specifically configured to apply controlled shear deformation to asphalt binder or bitumen samples; and for the determination of the elastic and viscous behavior of a bituminous binder. The system enables measurement of flow properties (such as shear viscosity from flow tests) and dynamic material properties (such viscoelastic modulus and phase angle from oscillation tests) to Asphalt industry standards.

The DSR has been designed to satisfy the demands of high throughput grade testing of Asphalt binders (bitumen) to AASHTO Specifications. Integrated fluid immersion cell specifically based on patented principle for temperature control of highly thermally-sensitive asphalt or bitumen samples.

Excellent temperature stability and accuracy: +/- 0.01 °C. resolution. Rapid, robust manual gap set, with pre-set gaps for AASHTO tests for simplicity of use. Plate measuring systems, both upper and lower plates, designed to comply with industry Standards (AASHTO).

Dedicated AASHTO specification QC software package (TruGrade) available.

Multiple stress creep recovery kit (MSCR) to ASTM D4705 test.

Specifications:

- Torque range: 10 µNm to 10 mNm
- Torque resolution: 1 µNm
- Position resolution: 1 µrad
- Frequency range: 10 µHz to 100 Hz
- Temperature control range: 5°C to 95°C (total immersion cell)
- Temperature accuracy: better than ± 0.1°C.

The Rheometer requires to be connected to:

- PC and color printer
 - Compressed air: 6 bar clean, dry air
- That are not included in the supply.

Power supply: 110V or 220V 1ph 50/60Hz

Dimensions: 230 x 350 xh 600 mm. Weight: 18 kg



B085-07



B085-05

BBR - Bending Beam Rheometer

STANDARDS: ASTM D6648 / AASHTO T313

Bending Beam Rheometer is engineered to perform flexural tests on asphalt binder and similar specimens. These tests consist of a constant force being applied to a specimen in a chilled bath in order to derive specific rates of deformation at various temperatures.

TEST FRAME:

- Three-point bend test apparatus
- Integral stainless steel frictionless construction
- Load cell 500 g with mechanical overload protection
- Linear Variable Displacement Transducer (LVDT) 0.25 in (6,35 mm)
- Two independent platinum RTD for precise temperature control
- Liquid bath:
 - stainless steel construction
 - temperature range: -40 to 25°C
 - mechanical refrigeration system
 - cooling coil located within the test bath
 - no pumping required. Cools Ethylene Glycol - water - methanol mix (recommended for safety) to -40°C.
- Compressed air: 0.34 MPa clean, dry air supply required
- CE certified model

SOFTWARE:

- Control, acquisition and analysis software
 - BBR Software version 4.16W
 - Computer interface card
 - Menu driven program, mouse compatible
 - Daily calibration routines
 - Displays and graphs real time load, displacement and bath temperature
- The BBR System includes: complete calibration kit with carrying case, 5 specimen molds with accessories, PC, accessories.
- Power supply: 230V 1ph 50/60Hz
Weight: 110 kg approx.

B091N

Pressure Ageing Vessel (PAV3)

STANDARDS: EN 14769 / ASTM D652 / AASHTO R28

The unit has been developed to simulate the accelerated ageing of bitumen and bituminous binders after 5 to 10 years.

The sample is exposed to high pressure and temperature for 20 hours, to simulate the effect of a long time oxidative ageing by verifying the penetration and softening point characteristics.

PAV3 features include:

- Touch screen controller with front panel user interface with easy to use step-thru operation.
- Bench top unit with integral vessel/oven design.
- USB port on front unit with software upgrades and data storage.
- Remote capabilities: with APP control PAV with smart phone, tablet or iPad.
- Timer to set time and date for automatic preheat.

Construction: CE certified vertical stainless steel pressure vessel with encased band heaters and integral pressure measurement control. Temperature is measured by Platinum RTD.

Specifications:

- Operating pressure: 2.1 +/- 0.1 Mpa
- Temperature range: 80°C to 115°C, res: 0.1°C
- Test temperature uniformity: +/- 0.5°C
- Time to return to set point temperature: less than 60 min.



B085-05



B091N

The unit is supplied complete with:
10 specimen pans AASHTO T179; O-Ring; precision anodized aluminum sample rack; Hex socket wrench; specimen loading/unloading tool; single stage regulator; high pressure hose assembly; instruction manual. Power supply: 230V 1Ph 50/60Hz 10A
Dimensions: 760x460x700 mm. Weight: 130 kg

NOTE: a source of compressed air with a pressure of at least 325 psi and a pressure regulator is required to operate the PAV

B091-01

Vacuum Degassing Oven for PAV

For degassing pressure aged binder samples to precisely and accurately meet ASTM D6521 and AASHTO R28 Standards. Stainless steel construction, hinged lid to conserve space and access the vacuum chamber, holds up to 4 specimen containers. Self-contained automatic vacuum system, high precision digital display controller indicating: time, temperature, current stage of each process. It maintains temperature up to 170°C with accuracy +/- 5°C
Power supply: 230V 1ph 50Hz. Dimensions: 610x400x305 mm
Weight: 60 kg approx.



DYNAMIC VISCOSITY BY ROTATIONAL VISCOMETERS

STANDARDS: EN 13302 / ASTM D2196 / AASHTO T316

Test Method: Determines the dynamic viscosity of a substance by the rotation of a specified spindle within the sample at the speed giving the maximum torque reading on the viscometer. The resulting torque reading is used to calculate the viscosity of the substance.

AVAILABLE MODELS:

B085-20

Rotational Viscometer, standard model

- Viscosity range: 20 - 13,000,000 cP in 114 ranges
- Rotational speed range: 0.3 - 200 rpm
- Accuracy: $\pm 1\%$ of full scale
- Repeatability: $\pm 0,2\%$
- Temperature range: -15°C to +180°C
Resolution 0.1°C
Precision: $\pm 0.1^\circ\text{C}$
- Touch key board with 5 keys
- Direct readout on graphic display
- Data displayed: Selected speed: rpm; Spindle used; Dynamic viscosity: mPas or cP; Full scale percentage: %; Sample temperature: °C or °F, Auto range to display viscosity limits
- This instrument determines both relative and absolute viscosity
- RS232 unidirectional interface
- Auto alarm in the case of the viscometer works out of the used spindle range
- Stainless steel spindles R2, R3, R4, R5, R6 and R7.

Basic software features:

The software allows downloading data directly from Viscometer. Measured values are shown in a chart and can be saved in Excel format for posterior evaluation.

Supplied as a complete system in a very robust carrying case, including a complete set of standard spindles with storage rack (6 spindles) spindle guard, temperature sensor PT 100 and calibration certificate.

Power supply:
230V 50-60Hz 1ph
Weight:
11 kg approx.



B085-20 / B085-30

B085-30

Rotational Viscometer, high performance model

Basically similar to standard model, but in addition:

- Viscosity range: 20 - 40,000,000 cP in 126 ranges
- Rotational speed range: 0.1 - 200 rpm
- RS232 bi-directional interface

Advanced software features:

The software permits to remote control of the viscometer through PC. In addition the software allows to program different analysis methods (processes) to obtain graphics and charts including test data. Results obtained can be displayed in graphics. Viscosity plots can be configured vs. different parameters.

Supplied as a complete system in a very robust carrying case, including a complete set of standard spindles with storage rack (6 spindles) spindle guard, temperature sensor PT 100 and calibration certificate.

Power supply: 230V 50-60Hz 1ph
Weight: 11 kg approx.



B085-20 / B085-30
with accessories in the carrying case

ACCESSORIES (for both models):

B085-32

TEMPERATURE CONTROL UNIT UP TO 200°C

Temperature range from 5°C to 200°C according to the specification of EN 13302 and AASHTO T316.

Complete with 12 liters tank.

B085-33

TEMPERATURE CONTROL UNIT UP TO 300°C

Temperature range from 5°C to 300°C according to the specification of ASTM D4402, EN 13302 and AASHTO T316.

Complete with 50 stainless steel disposable chambers for samples.



DYNAMIC VISCOSITY

Determination

B088

Viscometer bath

STANDARDS: Comparable to EN 12595 / ASTM D2171
AASHTO T201

This precision viscometer bath is used to determine both the Dynamic and Kinematic viscosity of liquid asphalts, keeping the capillary type viscometers at an uniform temperature.

Consisting of:

- glass container, 20 liters capacity,
- stainless steel lid with five holes for capillaries,
- selector and digital temperature reading,
- motor stirrer, heating element.

Allows to simultaneous temperate five capillaries.

Temperature range: room +5°C. to 150°C.

Temperature stability: $\pm 0,1^\circ\text{C}$.

Temperature sensor: PID

Protection against temperature excess and low liquid level.

Viscometers and thermometers are not included.

Power supply: 230V 1ph 50/60Hz 2000W

Weight: 10 kg



Cannon-Manning vacuum viscometers

To determine the viscosity of bitumen at 60°C.

Supplied complete with calibration certificate

| Model | Viscosity range |
|----------------|-----------------|
| B088-20 | 0,036 to 0,8 |
| B088-21 | 0,12 to 2,4 |
| B088-22 | 0,36 to 8 |
| B088-23 | 1,2 to 24 |
| B088-24 | 3,6 to 80 |
| B088-25 | 12 to 240 |
| B088-26 | 36 to 800 |
| B088-27 | 120 to 2400 |
| B088-28 | 360 to 8000 |
| B088-29 | 1200 to 24000 |
| B088-30 | 3600 to 80000 |



Note: to measure the viscosity with the Cannon-Manning viscometers, the B088 bath, the B088-05 holder, the B088-16 pressure regulator and the B088-17 vacuum manifold are also needed.

Asphalt Institute vacuum viscometers

To determine the viscosity of bitumen at 60°C.

Supplied complete with calibration certificate

| Model | Viscosity range |
|----------------|------------------|
| B088-34 | 42 to 800 |
| B088-35 | 180 to 3200 |
| B088-36 | 600 to 12800 |
| B088-37 | 2400 to 52000 |
| B088-38 | 9600 to 1400000 |
| B088-39 | 38000 to 5800000 |



Note: To measure the viscosity with the Asphalt Institute vacuum viscometers, the B088 bath, the B088-05 holder, the B088-16 pressure regulator and the B088-17 vacuum manifold are also needed.



B088-16

B088-16

Viscometer pressure regulator, for precise control. 230V 1ph 50/60Hz

B088-17

Vacuum manifold, to obtain vacuum to the viscometers introduced into the bath



B088



NOTE:

On request the viscometer bath is available with temperature stability:

$\pm 0,01^\circ\text{C}$ as requested by EN 12595 (code number: **B088-01**)

$\pm 0,03^\circ\text{C}$ as requested by ASTM D2171 (code number: **B088N**)

ACCESSORIES:

B088-03 Silicone oil, type 50 CSt, for tests with B088 bath with temperature range: 90°C up to 150°C. Can of 25 kg (20 lt approx)

B088-05N Holder, stainless steel made, for Cannon-Manning and Asphalt Institute viscometers

B088-06N Holder, stainless steel made, for Cannon-Fenske viscometers

B088-07N Holder, stainless steel made, for Zeitfuchs cross-arm viscometers

B088-08N Holder, stainless steel made, for Cannon BS reverse flow viscometers

B088-12 Kinematic viscosity thermometer, range 58,5 to 61,5°C, type ASTM 47C

B088-13 Kinematic viscosity thermometer, range 133,5 to 136,5°C, type ASTM 110C

KINEMATIC VISCOSITY

Determination

STANDARDS: EN 12595 / ASTM D2170
AASHTO T201



Cannon-Fenske opaque viscometers, reverse-flow type

To determine the kinematic viscosity of bitumen, distillation residues of opaque liquid asphalts, asphalt cements at 135°C., and road oils at 60°C.

Supplied complete with calibration certificate.

| Model | Approx. constant mm ² /s ² | Viscosity range mm ² /s |
|----------------|--|------------------------------------|
| B088-50 | 0,002 | 0,4 to 2 |
| B088-51 | 0,004 | 0,8 to 4 |
| B088-52 | 0,008 | 1,6 to 8 |
| B088-53 | 0,015 | 3 to 15 |
| B088-54 | 0,035 | 7 to 35 |
| B088-55 | 0,1 | 20 to 100 |
| B088-56 | 0,25 | 50 to 200 |
| B088-57 | 0,5 | 100 to 500 |
| B088-58 | 1,2 | 240 to 1200 |
| B088-59 | 2,5 | 500 to 2500 |
| B088-60 | 8 | 1600 to 8000 |
| B088-61 | 20 | 4000 to 20000 |
| B088-62 | 45 | 10000 to 40000 |
| B088-63 | 100 | 20000 to 80000 |



Note: to measure the kinematic viscosity with the Cannon-Fenske viscometers, the B088 bath and the B088-06 holder are also needed.



Note: to measure the kinematic viscosity with the BS viscometers, the B088 bath and the B088-08 holder are also needed.

Zeitfuchs cross-arm viscometers

To determine the kinematic viscosity of bitumen, distillation residues of liquid asphalts, asphalt cements at 135°C., road oils. Supplied complete with calibration certificate.

| Model | Approx. constant mm ² /s ² | Viscosity range mm ² /s |
|----------------|--|------------------------------------|
| B088-70 | 0,003 | 0,6 to 3 |
| B088-71 | 0,01 | 2 to 10 |
| B088-72 | 0,03 | 6 to 30 |
| B088-73 | 0,1 | 20 to 100 |
| B088-74 | 0,3 | 60 to 300 |
| B088-75 | 1 | 200 to 1000 |
| B088-76 | 3 | 600 to 3000 |
| B088-77 | 10 | 2000 to 10000 |
| B088-78 | 30 | 6000 to 30000 |
| B088-79 | 100 | 20000 to 100000 |

Note: to measure the kinematic viscosity with the Zeitfuchs cross-arm viscometers, the B088 bath and the B088-07 holder are also needed.



section B



145

Cannon BS-IP-RF flow reverse viscometers

To determine the kinematic viscosity of bitumen, distillation residues of liquid asphalts, asphalt cements at 135°C., road oils. Supplied complete with calibration certificate.

| Model | Approx. constant mm ² /s ² | Viscosity range mm ² /s |
|----------------|--|------------------------------------|
| B088-80 | 0,003 | 0,6 to 3 |
| B088-81 | 0,01 | 2 to 10 |
| B088-82 | 0,03 | 6 to 30 |
| B088-83 | 0,1 | 20 to 100 |
| B088-84 | 0,3 | 60 to 300 |
| B088-85 | 1 | 200 to 1000 |
| B088-86 | 3 | 600 to 3000 |
| B088-87 | 10 | 2000 to 10000 |
| B088-88 | 30 | 6000 to 30000 |
| B088-89 | 100 | 20000 to 100000 |
| B088-90 | 300 | 60000 to 300000 |

MATTEST



Duriez test set

STANDARD: NF P98 - 251-1/4

Used to determine the mechanical and physical properties of bituminous mixtures.

Duriez test set for 120 mm dia. specimens:

- B095-01** Testing mould
- B095-02** Penetration piston
- B095-03*** Penetration piston grooved
- B095-04** Upper/Lower piston
- B095-05*** Upper/Lower piston grooved
- B095-06** Two temporary supports
- B095-07** Demoulding cylindrical container

Duriez test set for 80 mm dia. specimens:

- B096-01** Testing mould
- B096-02** Penetration piston
- B096-03*** Penetration piston grooved
- B096-04** Upper/Lower piston
- B096-05*** Upper/Lower piston grooved
- B096-06** Two temporary supports
- B096-07** Demoulding cylindrical container

* Used for cold mixtures with bituminous emulsions



B095-01 ÷ B095-07

S206N

UNITRONIC 200 kN "Matest Made"

UNIVERSAL ELECTROMECHANICAL FRAME FOR COMPRESSION TESTS ON DURIEZ SAMPLES 80 MM AND 120 MM DIAMETER, WITH SERVOCONTROLLED SYSTEM OF LOAD OR DISPLACEMENT/STRAIN.

The machine is also suitable for tests on:

- Bituminous mixtures (Marshall, Leutner shear, Splitting tensile)
- Concrete (flexure on beams and clay tiles, splitting on cylinders, cubes and block pavers, punching)
- Cement and mortar (compression and flexure)
- Soil (CBR)
- Steel rebars (tensile)

Technical details: see pag. 420

B099-10

Sand patch equipment

STANDARDS: EN 13036-1 / ASTM E965 / CNR N. 94
NF P98 216-1

Road and airfield surface characteristics.

Measurement of pavement surface to determine the average macrotexture depth using a volumetric patch technique.

The equipment comprises:

Spreader disc with handle and rubber coated surface. Wind shield
Soft brush. Screw-adjusted compass 500 mm graduated rule.

Metallic cylinder for spheres volume measurement.

Two glass pyknometers with metallic screw top and pouring hole

Three graduated cylinders 10, 25 and 50 ml cap.

Knee-guard

Carrying case

Weight. 4 kg approx.



B099-10

ACCESSORIES:

B099-15 GLASS SPHERES, size 250/180 microns to EN 13036-1
Pack of 5 kg.

B099-16 NATURAL SAND 300/150 microns, 25 kg bag.
ASTM E965.

B099-17 NATURAL SAND 150/75 microns, 25 kg bag.
ASTM E965



S206N

B098N

Travelling beam device
Matest Made



Used to detect and check any irregularity in both bituminous and concrete road surfaces. The unit consists essentially of a 3 metre long beam fixed on two rigid wheels at the extremities. In the middle of the beam a sensing unit comprising a wheel connected to an indicator provides a magnification of 4:1 and measures deviations of the surface. The deviations are shown on a scale calibrated in increments of 2 mm up to 10 mm and 5 mm up to 25 mm. The beam is supplied as three sub-assemblies which are quickly assembled on site.
Weight: 55 kg approx.

ACCESSORIES:

B098-01N

Autographic recording device
Matest made



When connected to the Travelling Beam Device mod. B098N, it provides a permanent record of the surface profile. It records up to 1000 metre surface on the special chart paper rolls. Supplied complete with 10 chart rolls and 2 fibre-tipped pens.

B098-03N

DYE-MARKER with paint bottle, used to identify suspect areas.

B098-05

WOODEN CARRYING CASE to house the Travelling Beam Device.

SPARE-PARTS:

B098-11 Pack of 10 chart rolls for approx. 1000 metre run.

B098-12 Fibre-tipped pen for use with the recorder.

B098-13 Dye-marker paint bottle.



section B



B111

“Non Nuclear” Electromagnetic Density Gauge, infrared temperature sensor

The Electromagnetic Density Gauge is a non nuclear sensing device that allow field density real time measurement of asphalt. This technically advanced instrument for quality control allow operators to immediately identify spots with low pavement density and trigger corrective actions leading to more uniform pavements.

The Electromagnetic densimeter allows:

- Pavement tests.
- Real time measurements, in a continuous mode.
- LCD visualization of:
 - Average density.
 - % Maximum density.
 - % Air voids.
- Non Nuclear device, so maximum safety for operator
- Storing up to 999 measurement data records and RS-232 computer interface.
- Infrared sensor for an accurate measurement of the road surface (optional).
- Rechargeable batteries for 32h continuous usage.
- Charging supply for standard 230V/50Hz or 12Vcc.

Dimensions: 229x406x152 mm. Weight: 5 kg



MATEST



B099 KIT



B099-01N

GRADUATED WEDGES, anodized aluminium alloy (set of two)



B099-01N

B100

Benkelman beam apparatus

STANDARDS: CNR N° 141

Alluminium alloy made, complete with dial indicator and accessories, it is utilized to measure the deflection of the road surface when loaded by the wheels of vehicles. The beam is put in contact with the pavement under test between the tires of the vehicle.

The measurement of the deflection is performed when the vehicle passes over the test area. Length of the Benkelman beam is 250 cm. Beam fulcrum ratio 4:1

Supplied complete with wooden carrying case.

Weight: 16 kg

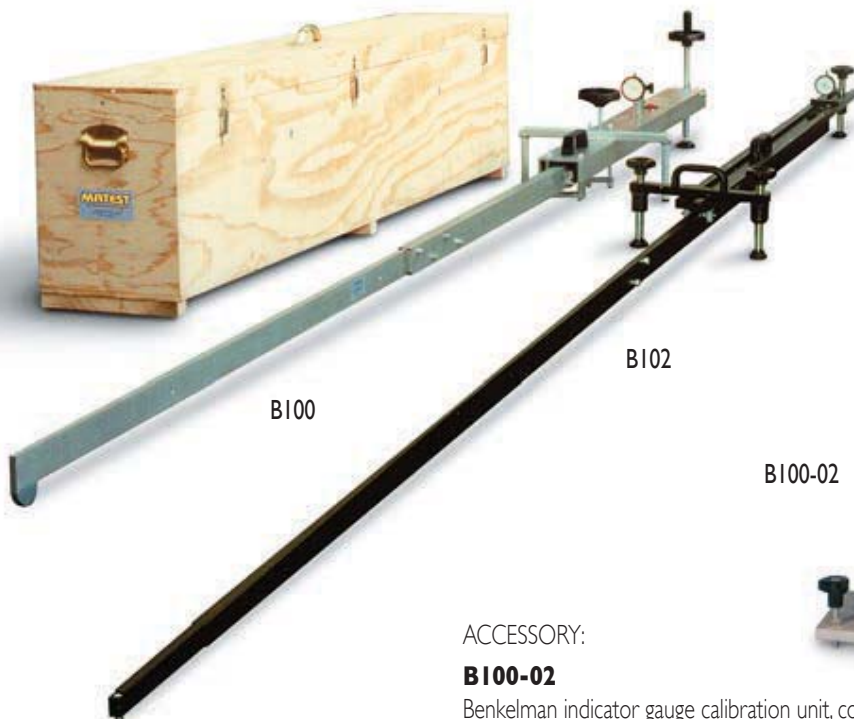

B100

B102

B100-02

B099 KIT

MOT straight edge

IRREGULARITY MEASUREMENT OF PAVEMENT SURFACE
STANDARD: EN 13036-7

Consisting of:

B099N

MOT straight edge

Manufactured from anodized aluminium alloy, it is utilized to measure irregularities of road pavement, floors, concrete pavement. Length is 3000 mm, width 26 mm, adjustable in height from 0 to 30 mm.

Supplied without graduated wedges.

Weight: 9 kg approx.

B102

Benkelman beam apparatus

STANDARD: NF P98-200-2 / AASHTO T256

Basically similar to mod. B100 but manufactured according to the French Specifications. Beam fulcrum ratio 2:1

Complete with wooden carrying case.

Weight: 16 kg

ACCESSORY:

B100-02

Benkelman indicator gauge calibration unit, complete for mod. B100 and B102.



B103-10
Bearing plate 600 mm dia. cast aluminium with reinforcing ribs

STANDARD: NF P94-117-1

The plate is equipped with a central device to measure the static deformation of road pavements (EV2) with the Benkelman Beam, and the bearing capacity of a soil in-situ.

(Standard: CNR N. 146, method A)

The plate foresees also three screwed lateral holes for three point measurements of the bearing capacity of a soil in-situ

(Standards: CNR N. 146 method B / BS 1377:9 / CNR N. 92 ASTM D1195, D1196)

Supplied complete with coupling device to the hydraulic jack.

Weight: 25 kg

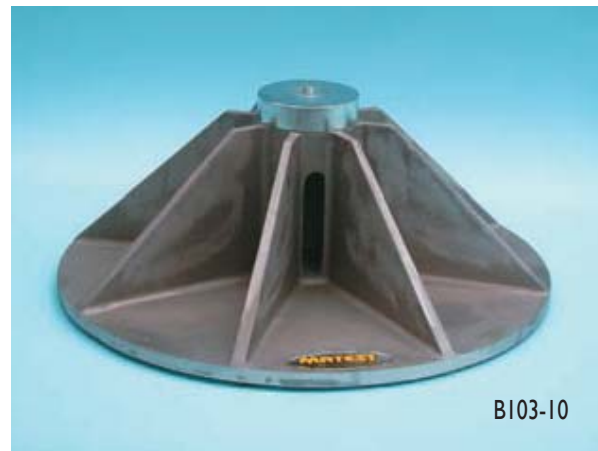

B103-10

USE EXAMPLES OF THE ALUMINIUM BEARING PLATE:

B103-05 KIT
Plate bearing equipment, 200kN capacity

STANDARD: NF P94-117-1

To determine the static deformation of flexible road pavement (EV2) in the centre of the loading plate.

Used with the Benkelman Beam apparatus mod. B100 and B102

The equipment consists of:

B103-10 Bearing plate 600 mm dia. cast aluminium with reinforcing ribs and coupling device.

S225-01 Hydraulic loading jack 200 kN capacity, complete with "double speed hand pump ensuring fast approach", rubber pipe with fast connector; set of extension rods of different lengths, carrying case.

S225-02 Precision pressure gauge 0 - 200 kN, div. 1 kN

S226-13 Upper spherical seat.

Total weight: 70 kg approx.

Note: each item can be ordered separately



B103-05 KIT

B100

ACCESSORIES:

B100 Benkelman Beam apparatus according to Standards: CNR N. 141

B102 Benkelman Beam apparatus according to Standards: NF P98-200-2 / AASHTO T256-77

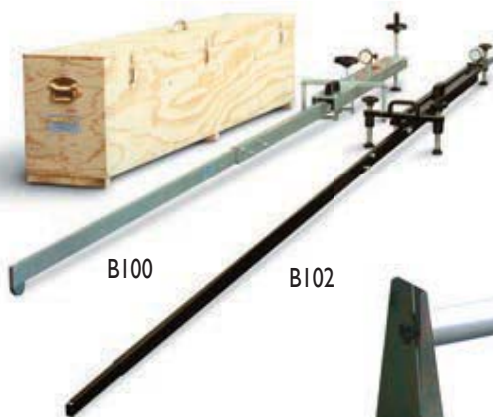

B100

B102

Use examples of the aluminium bearing plate 600 mm dia. for bearing tests of a soil in-situ with the 200 kN plate bearing equipment mod S225 KIT (see pag. 425 of the catalogue)



S225 KIT + B103-10



B114

Asphalt samples sealing device

STANDARDS: ASTM D6752 / ASTM D6857 / ASTM D7063 / AASHTO T-331

The device is a system for sealing samples for determination of bulk specific gravity (density) of compacted and loose asphalt mixtures. The system can also be used for determination of bulk specific gravity and absorption of aggregate and stone. This product is now the standard for measurement of bulk specific gravity of open graded and absorptive compacted asphalt samples.

The samples are automatically sealed in specially designed puncture resistant polymer bags. Densities measured with this system are highly reproducible and accurate. The results are not dependent on material type or sample porosity.

Vacuum Pump 1.25 HP

Power supply: 230V 1ph 50Hz 1430W

Dimensions: 490x640x510 mm

Weight: 91 kg

NEEDED ACCESSORIES:

B114-11

Small polymer bags 25x36 cm (pack of 100 pcs)

B114-12

Large polymer bags 38x46 cm (pack of 100 pcs)



B114

B115

Asphalt samples vacuum drying device

STANDARDS: ASTM D7227 / AASHTO PP75

The device is a vacuum drying device specifically designed for rapid drying of compacted asphalt cores and samples. The quick and accurate dry weight, helps contractors determine pavement density close to real time and make adjustments to rolling pattern and material if necessary. It can also provide a matching baseline for density comparison between contractors and agencies.

The device dries specimens near room temperature, ensuring sample integrity and the most accurate & repeatable dry weight. Rapid moisture loss is attributed to electronic desiccation and high vacuum technologies. The system cycles a flow of ambient air and vacuum, ensuring a highly efficient moisture removal process. The state-of-the-art and patented thermoelectric cold trap is specifically designed to protect the vacuum pump from damage by capturing moisture extracted from the sample.

Vacuum Pump: 1 HP

Power supply: 230V 1ph 50Hz 1650W

Dimensions: 810x600x880 mm

Weight: 77 kg



B115

