

Section E

CEMENT - MORTAR

section E



307



The raw materials like: limestone, chalk, shale, clay etc., mixed with water, are crushed, ground and blended. They are now submitted to a chemical process in a rotary kiln until they combine into clinker. From the clinker opportunely mixed with gypsum, the cement factories obtain the modern Portland cement, that may be modified in more and more sophisticated binders like expansive mortars, pre-mixed cements etc.

In section "Cement & Mortars" Matest proposes a complete range of equipment for:

Fineness, Consistency, Setting-time, Workability, Soundness, Flow, Fly Ash, Lime reactivity and Slaking, Chemical Tests etc.; and for Mixing, Moulding, Curing and Strength Tests, to satisfy all the above quality variables, in compliance with the EN, ASTM and the most known International Standards.



MATEST

BLAINE AIR PERMEABILITY APPARATUS TO DETERMINE THE FINENESS OF CEMENT

STANDARDS: EN 196-6, comparable to:
ASTM C204 / AASHTO T153 / BS 4359:2
UNI 7374 / NF P15:442 / UNE 80106 / DIN 1164

Available models

E009 KIT

Blaine air permeability (fineness) apparatus

Used to determine the fineness of Portland cement in terms of the specific surface expressed as total surface area in square centimeters per gram of cement.

The apparatus is supplied with glass U-tube manometer with valve, steel stand, test cell with disk and plunger all in stainless steel, rubber aspirator bulb, 1000 filter paper disks, manometric liquid, vaseline grease for better coupling tube/cell, funnel, brush.

Dimensions: 220x180x470 mm

Weight: 12 kg



ACCESSORIES:

E010-02 Standard reference cement 114g. to ASTM/SRM/EN to calibrate the Blaine

E055-08 Glass Thermometer -10 to +50° C.

SPARES:

E010-01 U-tube glass manometer complete

E010-03 Manometric liquid 250 ml bottle

E010-04 Filter paper discs, porosity: 2 micron (pack of 1000 pieces)

E010-08 Test cell, complete (three pieces)

E010-05 Cell body, stainless steel

E010-06 Cell plunger, stainless steel

E010-07 Cell perforated disk, stainless steel

E011N

Digital Blaine Air Permeability Apparatus, with display of time measured

Digital Blaine air permeability apparatus with automated test cycle, electric suction pump, photoelectric cells for detection of levels, chronometer start-up and stop.

After the test, automatic display of the time measured.

Precision of time displayed: 0.01 second.

The apparatus is delivered complete with:

Stainless steel cell with grid and plunger, bottle of manometric liquid, bag of 1000 filter paper disks, funnel.

Power supply:

230V 1ph 50Hz 20W

Dimensions:

300x250x510 mm

Weight: 8 kg



E011N

E011-01

Automatic Blaine Air Permeability Apparatus

This automatic electronic apparatus with microprocessor is equipped with an automatic airproof device.

The apparatus consists of a flat enclosure with a manometer column and with 4 components stainless steel measuring cell.

Depending to the cement porosity and its density, the equipment calculates automatically the masse that you have to test, determines the constant K according to standard cement, records the test results with possibility to elaborate an average value of different tests. RS 232 port

The defining of final Blaine value is automatically given by the apparatus.

Supplied complete with accessories

Power supply:

230V 1ph 50Hz

Dimensions:

280x325x410mm

Weight: 10 kg



E011-01



E014
Le Chatelier flask

STANDARDS: EN 196-6 / ASTM C188
AASHTO T133 / UNE 83453
Used to determine the relative density (specific gravity) of hydraulic cement and lime. Capacity 250 ml. The neck is graduated from 0 to 1 ml and from 18 to 24 ml with divisions of 0,1 ml.
Weight: 500 g

ACCESSORY:
V192-08
CHATTAWAY SPATULA, 120 mm long.



E016
Water flowing sieves device

STANDARD: D.M. 3/6/68
Used to determine the fineness of cement. It consists of a spraying unit with feed cock and gauge; brass sieve body 85 mm dia. and 95 mm high with two stainless steel cloth disks having opening 0,18 and 0,09 mm. A cement sample of 25 g. is placed inside the sieve and washed for two minutes by means of the spraying unit put on top of the sieve. The residue of the retained cement is obtained by drying the sieve at 110 °C.
Weight: 3 kg

SPARES: **E016-01** Stainless steel cloth disk, opening 0,18 mm
E016-02 Stainless steel cloth disk, opening 0,09 mm



E017
Fineness of fly ash by wet sieving

STANDARDS: EN 451-2 / ASTM D430
The set, brass made, consists of: sieve dia. 50 mm. with stainless steel mesh opening 0,045 mm, spray nozzle 17,5 mm ID with 17 holes dia. 0,5 mm, pressure gauge dia. 80 mm range 0-160 kPa, div. 5 kPa, fittings and connectors. Weight: 3 kg



E029
Measurer 400 ml capacity

STANDARDS: ASTM C185-85 / AASHTO T137
To determine the air content of freshly mixed mortars by the density method.
Steel made, internal diameter 76,2x88,1 mm height.

ACCESSORIES:
E087-06
HARD WOOD TAMPER

E055-07
GLASS PLATE, nominally 120 mm diameter

V192-08
CHATTAWAY spatula



E020
Bulk cement sampler

STANDARDS: EN 196-7 / ASTM C183 / AASHTO T127
Used to sample cement in bulk storages or shipment.
Brass made, it consists of two concentric tubes with slots.
Inside tube volume is 3 litres approx.
Dimensions: dia. 40x1500 mm. Weight: 5 kg

E021
Packaged cement tube sampler

STANDARDS: EN 196-7 / ASTM C183 / AASHTO T127
Used to sample cement homogeneously from cement bags.
Dimensions: dia. 32x1050 mm. Weight: 3 kg



E025
Bulk density of cement

This apparatus is used for the measurement of the apparent density (bulk density) of powders and non-cohesive materials. It consists of sieve funnel with tripod, unit weight measure 1 litre capacity, spatula, straight edge, aluminium scoop. The discharge hole of the funnel has 8 mm dia.
Dimensions: dia. 350x520 mm
Weight: 6 kg





E027

Air content meter 1 litre capacity

STANDARD: EN 459-2 / EN 1015-7

Designed to determine the air content in cement mortar, cement paste and lime mortar. Made from cast aluminium, the test pot one litre capacity and the upper part are air-tight sealed by means of two quick action spring clamps. The whole is connected to a dial gauge directly indicating the air entrainment in percentage, with range 0 - 50%. A built-in operated air pump is also included.

The push-buttons TEST and CORRECTION are arranged to perform the test in a simple and quick system.

Dimensions: dia. 200 by 320 mm

Weight: 3,5 kg

E027-01

Air content meter 0,75 litre capacity

STANDARD: EN 413-2

Identical to mod. E027, but with vessel having 0,75 litre capacity, conforming to EN 413-2 Specification.

E028

Air content meter 1 litre, electric

STANDARD: EN 459-2

Same as mod. E027, but with incorporated an electric mini-compressor giving air pressure and keeping it constant all along the test.

Power supply: 230V 1ph 50/60Hz

E028-02

Air content meter 0,75 litre, electric

STANDARD: EN 413-2

Identical to mod. E028, but with vessel having 0,75 litre capacity, conforming to EN 413-2 Specification.

ACCESSORY:

E028-01 Filling Hopper (Ring) for the meters E027, E027-01, E028, E028-02



E027



E028

E034

Apparatus for lime testing reactivity

STANDARDS: EN 459-2 / NF P98-102

This apparatus is used for determining the reactivity on slaking of ground quicklime.

The equipment consists of a Dewar vessel 1000 ml capacity complete with cover, electric stirrer 300 rpm. complete with stirring paddle (propeller), base with stand, digital thermometer range -50 +200°C. subd. 0,1°C., accessories.

Power Supply: 230V 1ph 50Hz

Dimensions: 400 x 250 x 750 mm

Weight: 10 kg approx.

ACCESSORY:

E034-05

Weighting and filling container

SPARE PARTS:

E034-11

Dewar vessel

E034-12

Stirring paddle (propeller)

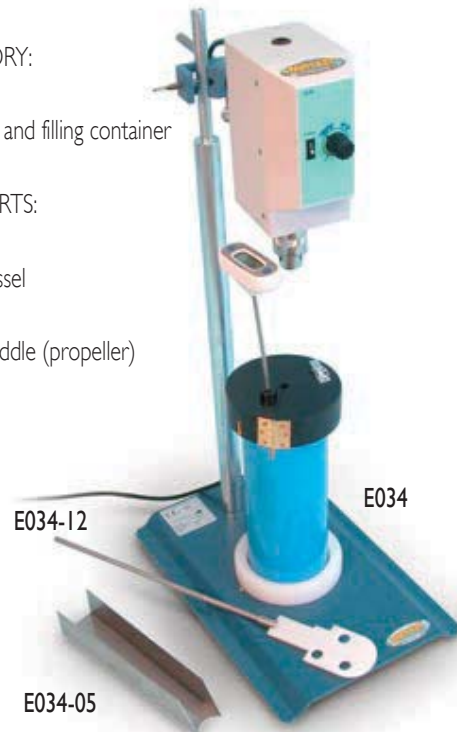

E035

Slaking vessel

BUILDING LIME – YIELD OF LIME

STANDARD: EN 459-2

This insulated vessel is used to determine the yield of lime by leaving the lime sample to slake into.

Stainless steel made, double walled insulated with glass fibres, the cylinder has inside dimensions dia. 113 by 140 mm deep.

Supplied complete with cover.

Weight: 4 kg approx.



E035

E091

Bulk density of lime

STANDARDS: EN 459-2 / DIN 1060

The apparatus allows a sample to fall from a known height into a volumetric container. Consisting of a hopper, one litre cylindrical container and spring loaded trap. Weight: 5 kg



E091

E031

Dropping ball apparatus

STANDARDS: BS 4551-1, 6463-4

Used to measure the consistency of cement mortars, this instrument allows a mm. 25 diameter acrylic ball to fall freely from a standard height of 250 mm. into a specimen of mortar contained into a brass ring mould, and the surface of which has been carefully prepared. The depth of the ball penetration into the mortar gives the specimen consistency. The instrument comprises a dropping device mounted on a stand, acrylic ball, mould dia. 100x25 mm. The base of the stand is machined. Chromed finishing. Weight: 8 kg

ACCESSORY:

E031-01

BALL PENETRATION MEASURING DEVICE, formed by a tripod on which a dial gauge 25x0,01 mm is mounted. A device to adjust the height of the dial in relation to the tripod is also included. Chromed finishing. Weight: 1 kg



E031

E031-01

E039N

Cement water retention apparatus

STANDARDS: ASTM C91, C110

Used to determine the water retention value of cement and lime putty. The unit comprises: water aspirator, mercury column manometer, three-way stopcock, metal perforated dish, glass funnel, mercury valve, pack of filter paper, accessories; the whole assembled on stand.

The vacuum pump with accessories are not included in the supply and have to be ordered separately, while the mercury (1 kg needed) cannot be supplied for shipping safety problems. Dimensions: 400x300x600 mm Weight: 8 kg approx.



E039N

ACCESSORIES:

V205 + V205-10 + V230-03

Vacuum pump with accessories. Power supply: 230V 1ph 50Hz See pag. 487

E036 KIT

Settling and swelling ratio apparatus of grouts. Container Method.

STANDARD: EN 445, comparable to DIN 4227 / UNI 8996, 8998

The equipment consists of:

- E036-10** Container, stainless steel (3 pieces).
 - E036-11** Cover, airtight, ballast, stainless steel (3 pieces).
 - E036-12** Plexiglass disc (3 pieces).
 - E036-13** Measuring bridge.
 - V175** Vernier caliper.
 - V102-02** Filling graduated measurer.
- Total weight: 4 kg approx.



E036 KIT



E038

Flow cone apparatus

STANDARDS: EN 445 / NF P18-358, P18-507

Used for viscosity and fluidity determinations of mortars, muds, grouts, fluid materials, etc. Cone top dia. is 155 mm, total length 290 mm, capacity 1700 cc.

Mortar fluidity is considered suitable when the flow time of 1000 cc of mortar is comprised between 17 to 25 seconds.

Entirely brass made, it is supplied complete with four interchangeable nozzles dia. 8 - 9 - 10 -

11 mm, stand adjustable in height, plastic graduated cup.

Weight: 10 kg

ACCESSORIES:

E038-01

Interchangeable nozzle dia. 12,5 mm.

E038-02

SIEVE, 150 mm dia., 1,5 mm mesh opening that fits the upper cone



E037

Marsh funnel viscometer

Utilized for viscosity determination on drilling muds and fluid materials.

Orifice opening 4,7 mm

Half part of the funnel mouth is foreseen of sieving cloth

2 mm mesh.

Plastic break-resistant made.

Supplied complete with

graduated cup.

Weight: 1 kg



E037-10

Sand Content of Drilling Muds

The Sand Content Kit is a simple, accurate and inexpensive sieve analysis apparatus for determining the sand content of drilling muds.

The kit consists of a special 200-mesh sieve 2,5" in diameter, fastened inside a collar upon which a small funnel is fitted on either end. This is used with a 10ml glass measuring tube, graduated to read from 0 to 20% the percentage sand by volume. The collar and funnel are made of polyethylene and the screen is made of brass. A 500 ml wash bottle and carrying case are included. Weight: 1500 g

E037-01

Baroid mud balance

It provides a simple method for the accurate determination of mud density.

The balance consists of a base and graduated arm with cup, lid, knife edge, rider, built-in spirit level and counter-weight, carrying case. The constant volume cup is affixed to one end of the graduate arm and the counter-weight on the opposite end.

Weight: 5 kg



E037-01

E037-05

Filter press for muds

STANDARD: API (American Petroleum Institute), recommended practice 13B-1 and 2

This filter press is the most effective means for determining the filtration properties of drilling muds and cement slurries.

The filter press consists of a mud reservoir mounted in a frame, a pressure source, a filtering medium, and a graduated cylinder for receiving the measuring filtrate, pack of 100 filter paper; nitrogen pressurized cartridges.

Dimensions:

210x240x500 mm approx

Weight : 12 kg



E037-05



E037-10



E055N**Vicat apparatus****DETERMINATION OF SETTING TIME AND CONSISTENCY OF CEMENT**

STANDARDS: EN 196-3:2005 / EN 13279-2 (gypsum)

EN 480-2 / ASTM C187, C191

AASHTO T131 / DIN 1196, 1168 / BS 4550

NF P15-414, P15-431 / UNE 80102

The instrument consists of a metallic frame, graduated scale with index, sliding probe of 300 g, consistency plunger dia. 10 mm, glass base plate.

The **needle and conical mould** are not included and have to be ordered separately according to the selected Standard (see accessories)

Dimensions: 160x200x300 mm. Weight: 5 kg

**"NEEDED" ACCESSORIES:****E046N** Needle, hardened dia. 1,13 mm EN 196-3:2005**E046-01N** Needle, hardened dia. 1 mm ASTM - AASHTO**E055-10** Conical plastic mould dia. 70/80 h 40 mm (EN - NF)**E055-05** Conical plastic mould dia. 60/70 h 40 mm (ASTM - AASHTO)**CONICAL MOULDS TO BS, DIN, UNI SPECIFICATIONS:****E055-04** Conical plastic mould dia. 80/90 h 40 mm (UNI)**E055-13** Conical plastic mould dia. 65/75 h 40 mm (DIN)**E055-11** Conical brass mould dia. 80/90 h 40 mm (BS)**ACCESSORIES:****E055-06** Additional weight 700 g to the sliding probe (EN - NF)**E042N** Final needle dia. 1,13 mm
(EN - NF - BS - DIN - UNI - UNE)**E042-01N** Final needle dia. 1 mm (Standards: ASTM - AASHTO)**E055-08** Glass thermometer -10 to +50° C.**E044-40N** Conical penetration needle dia 8 mm by 50 mm long
for gypsum tests. Standards: EN 13279-2 / DIN 1168**E055-15** Probe, total weight of 100 g for tests on gypsum,
EN 13279-2 / DIN 1168**SPARE PARTS:****E055-07** Glass base plate dia. 120 mm**E044-48N** Tang to fix the needle to the probe**E042-02N** Consistency plunger dia. 10x50 mm**E058****Gillmore apparatus**

STANDARDS: ASTM C91, C141, C266 / AASHTO T154

Used to determine the setting time of cement. Vertical support shaft has a device to maintain the horizontal arms in alignment. Support assembly is adjustable in position. The two steel weights needles are calibrated to meet Specifications. Needle points are from stainless steel. The initial setting needle has dia. 2,12 mm and weight of 113 g, while the final setting needle has dia. 1,06 mm and weight of 453,6 g.
Weight: 3 kg

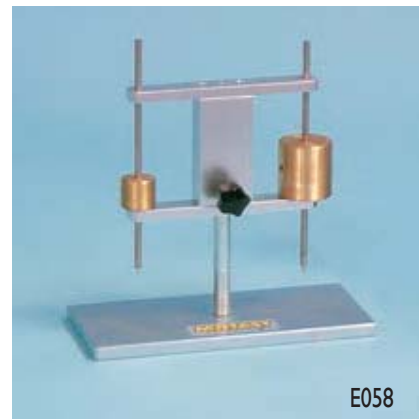

E044N

VICATRONIC

AUTOMATIC COMPUTERISED TROPICALIZED VICAT RECORDING APPARATUS

STANDARDS: EN 196-3:2005 / EN 13279-2 (gypsum) / EN 480-2 / ASTM C187, C191 / DIN 1168, 1196 / BS 4550 / UNE 80102
NF P15-414, P15-431 / AASHTO T129, T131

The Vicatronic apparatus, that is designed and manufactured using the most recent and sophisticated technology, is used for the initial and final setting time determination of cements or mortar pastes.

The unit is manufactured with "anticorrosion and tropicalised" components to be used in places with humidity not below 90% and 20°C, controlled temperature as required by EN Specifications.

The entire test is made in a fully automatic way and gives a very precise and repeatable result. The results are printed on the incorporated printer and this eliminates the manual operations of installing and zeroing the paper graph on the drum.

The use of the appliance is extremely simplified by the guiding menu that is available in english, french, spanish, german, polish, italian language.

section E



314

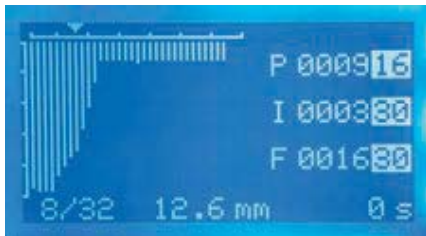

DISPLAY

The large high contrast LCD display (negative blue) has a high resolution and shows the test data together with the general functions of the appliance. It visualises for the first time in real time the graph of the test (see picture) replacing and simulating what the old fashioned pen tracing on the paper. The appliance has a clock calendar that is used to program the test cycles.

FIRMWARE

The Vicatronic is supplied with the standard programs to make automatically, all the tests according to the following Standards:

EN 196-3:2005 / EN 13279-2 gypsum / EN 480-2 / ASTM C191
DIN 1164 / DIN 1168 gypsum / NF P15/431 / BS 4550 / AASHTOT 131

Further programs can be developed by the operator using the specific menu "free tests" available on the base firmware; the user has the possibility to set 5 totally free test profiles defining the number of penetrations and the coordinates of each penetration (ray in mm of the circle where the number of penetrations have to be distributed) and number of circles. This possibility is particularly useful when testing new mortars, additives and to make research tests that requires sophisticated and flexible applications.

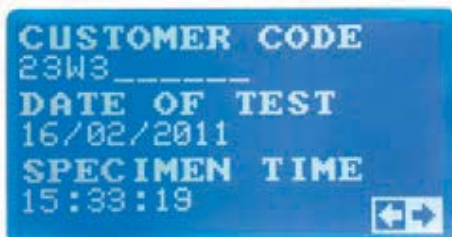

90 penetrations program

ASTM

EN

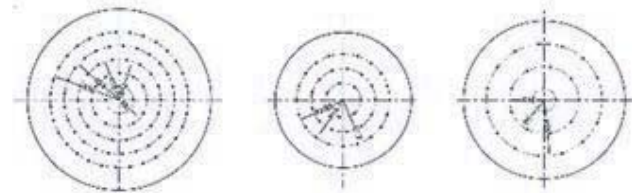

MATEST



PROBES

The mobile probe weighs 300 g (1000 g following the EN, NF Standards), the penetration needle has 1,13 mm diameter (1 mm following ASTM Standard) and its fall can be programmed in free fall or in guided fall. Totally flexible as far as the time is concerned, the penetrations time can be selected between 0,5 minutes and 999 minutes (fix interval between two penetrations of a test) or can change during the test up to 5 different phases with different interval time; it can even change automatically during the setting time fixing a penetration depth. The two options described here above can be combined together.

The penetration measure is read by a very accurate encoder having a resolution of 0,1 mm.

The Vicatronic also calculates, visualises and prints:

- The time from the moment of the sample preparation (set by the operator).
- The time the test starts.
- The residual time to the next penetration.
- The residual time to the end of the test
- The number of penetrations made and the residual penetrations to be made.

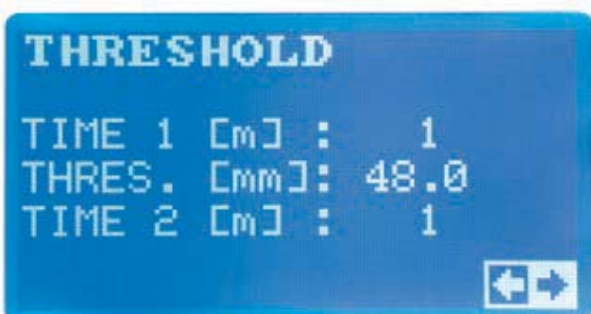
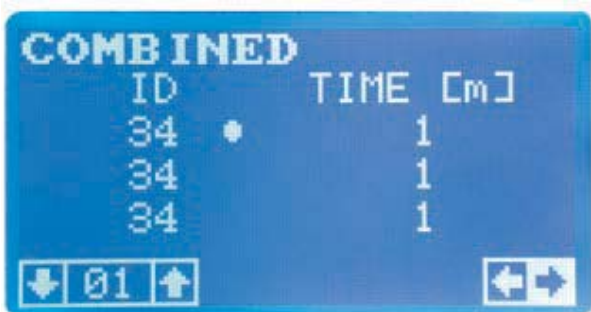

TIMER 0 – 999 MINUTES

The firmware allows activating a delay on the appliance to the beginning of the test. This program is particularly useful when the approximate setting time of the mortar is known and the operator wants to start the working of the Vicatronic after a certain time in order to concentrate the penetrations with a short interval of time between them and have better measuring values.

TEST RESULTS

The Vicatronic can memorise all the test parameters and results and keeps a file with a capacity of more than 50 complete tests.

In case of a power cut, even a short one, during the test execution, the test will be invalidated and the appliance will be automatically stop keeping the set data.

At the end of the test the appliance will print automatically by the incorporated printer a report with all the data concerning the last test made including a graph tracing each single penetration with its values of time and penetration number (see example printed).



TEST NUMBER	: 0996	
KIND OF TEST	: BS4550	
POINTS MOVE [mm]		
17	0.00	
11	10.00	
5	10.00	
1	10.00	
OPERATOR CODE	: F	
CUSTOMER CODE	: 23M3	
DATE OF TEST	: 15/02/2011	
SPECIMEN TIME	: 14:36:16	
START DELAY[m]	: 1	
1ST PEN TIME	: -----	
SPECIMEN TYPE	: X5	
WATER CONT. [%]	: 89.0	
TEMPERATURE [°C]	: 22.3	
HUMIDITY [%]	: 69.1	
FALL TYPE	: DRIVEN	
TIME TYPE	: FIXED	
FINAL SETTING	: NO	
TIME [m]	: 1/2	
ID PEN. [mm]		
	P [m.s] I [n.s]	
ID	PEN. [mm]	
1	0.0	-----
2	0.0	-----
3	0.0	-----
4	0.0	-----
5	0.0	-----
6	0.0	-----
7	0.1	-----
8	5.4	-----
9	6.6	-----
10	7.9	-----
11	9.3	-----
12	11.1	-----
13	12.6	-----
14	13.6	-----
15	14.9	-----
16	15.8	-----
17	16.5	-----
18	19.3	-----
19	20.3	-----
20	21.6	-----
21	23.1	-----
22	24.0	-----
23	26.7	-----
24	28.3	-----
25	29.6	-----
26	31.1	-----
27	35.0	-----
28	37.2	-----
29	39.8	-----
30	40.5	-----
31	42.6	-----
32	42.5	-----
33	42.9	-----
34	42.9	-----

PRINTING EXAMPLE



PC CONNECTION AND NET OPTIONS

Despite the totally independent working of the machine that includes an incorporated printer, the Vicatronic has been designed for a PC connection (RS232) with the possibility to download the test data using a common program (Microsoft Hyper Terminal) that is normally incorporated with the Windows package of the PC. In this case the data processing will have to be made by the operator.

The "Vicat-Win" software (accessory mod. E044-11) allows receiving, managing, processing and completing the test dates; it will trace automatically the graph, personalise and print the test report.

The Vicatronic offers the possibility, buying the kit "Vicat-Net" (accessory mod. E044-12), to connect up to 20 appliances on a net managed by a PC through two pins RJ45 with RS485 protocol. This allows obtaining a complete remote control from the PC of each single Vicatronic.

The details of the performances are following:

- Transfer each single control or function of the Vicatronic on the PC
- Verify in real time each phase of the test being made.

- Automatically download the final results at the end of the test on all the connected Vicatronic.
- Process and file at the same time all the tests without obliging the operator to move from his working place.

Additionally the firmware has many other functions detailed in the technical chart that will be transmitted to the user interested to know more about it.

The Vicatronic is supplied complete with the incorporated printer, two hardened needles (one with 1 mm diameter and one with 1,13 mm. diameter), two conical moulds EN and ASTM, a glass plate to hold the conical mould.

Power supply: 230 V I Ph 50/60 Hz. 50W

Dimensions: 400 x 200 xh 470 mm. h.

Weight: 13 kg.

E044-03 N

VICATRONIC, identical to mod. E044 N, but with possibility of continuous penetrations each 15 seconds..



ACCESSORIES:

E044-11 Software "VICAT-WIN" complete with connection cable of 3 metres that allows by the RS232 port downloading, processing, printing and managing all the data directly from the PC.

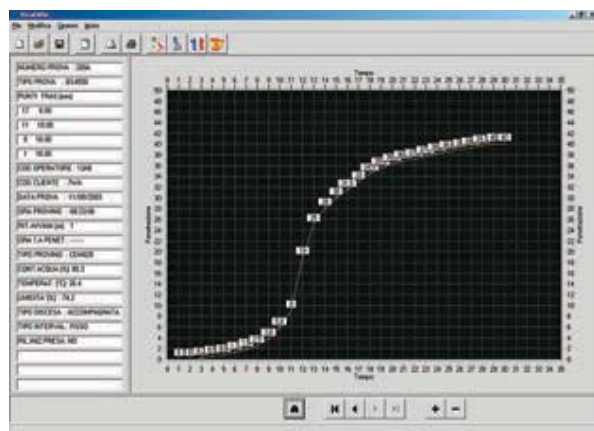

Time (s)	Penetration (mm)
1	0.0
2	0.0
3	0.0
4	0.0
5	0.0
6	0.0
7	0.0
8	0.0
9	0.0
10	0.0
11	0.0
12	0.0
13	0.0
14	0.0
15	0.0
16	0.0
17	0.0
18	0.0
19	0.0
20	0.0
21	0.0
22	0.0
23	0.0
24	0.0
25	0.0
26	0.0
27	0.0
28	0.0
29	0.0
30	0.0

E044-12 Kit "VICAT-NET" to connect up to 20 Vicatronic on a net by means of two connectors RS485 managed by a PC. The kit includes: the software, the RS232/485 converter and the cable for the connection of "one appliance". For net connection of additional Vicatronics (up to max. 20) see the below accessory mod. E044-13

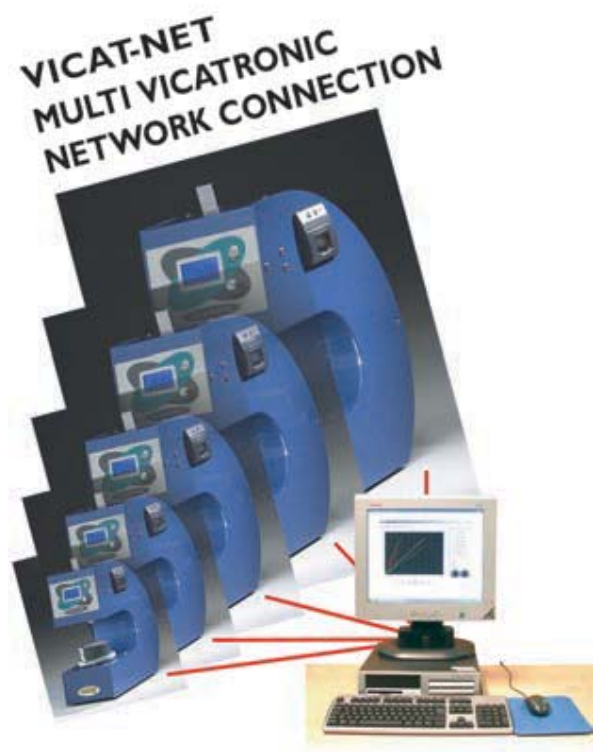

E044-13

Complete kit with cable for serial connection RS485, 5 metres long for the connection of one Vicatronic to the PC or to a net (cables with different length are available on demand).



E043
MOULD TANK to test the specimen immersed in water. The test must be performed in room having a controlled temperature of 20° C. ± 1° C. The saturated humidity is obtained by the immersion in water of the specimen as required by the standard EN196-3.



E044-20 + E044N + E043

E044-20
THERMOSTATICALLY CONTROLLED HEATING/COOLING SYSTEM
The device produces water at a controlled temperature of 20° C. ± 1° C. that is circulated into the tank E043 to perform the test at controlled temperature and humidity as required by the Standard EN196-3. Can be used only with one single Vicatronic.
Power supply: 230V 1F 50Hz 1300W
Dimensions: 300x440x650 mm. Weight: 31 kg.

E044-21
THERMOSTATICALLY CONTROLLED HEATING/COOLING SYSTEM
Same as the mod. E044-20 but can be used simultaneously for "TWO" Vicatronic.

E044-30
NEEDLE CLEANING DEVICE
It removes the residual cement particles from the needle keeping it constantly lubricated.



E044-25
THERMOSTATICALLY CONTROLLED HEATING SYSTEM WITH COOLING COIL.
The apparatus heats water from room temperature to 20 +/- 0,1°C. The unit consists of a stainless steel water bath 10 litres capacity with wool insulation, immersion heater with digital thermostat, motor pump, inlet/outlet system to circulate the water into the E043 tank, cooling coil device current water operated, to maintain a constant temperature of the bath when room temperature is slightly higher.
The E044-25 unit is also a general purpose laboratory water bath

with temperature range from room to 35°C. +/- 1°C.
Power supply: 230V 1ph 50Hz 1050W
Dimensions: 375x335x420 mm
Weight: 12 kg



E044-25 + E044 N + E043

Gypsum test: EN 13279-2 / DIN 1168

E044-40 N
CONICAL PENETRATION NEEDLE, having 8 mm. diameter and 50 mm. long, to make gypsum tests following EN, DIN Specifications.

E044-41 N
PROBE 100 g, to make test on gypsum following EN, DIN Specifications.



- E042-02N** Consistency plunger dia. 10x50 mm
- E042N** Needle for final setting 1,13 mm. diameter, BS, EN 196-3:2005
- E042-01N** Needle for final setting ASTM 1 mm. diameter.
- E044-45** Additional 700 g weight (EN, NF)
- E055-04** Plastic mould Ø 80/90 x 40 mm. high following UNI
- E055-11** Brass mould Ø 80/90 x 40 mm. high following BS
- E055-13** Plastic mould Ø 65/75 x 40 mm. high following DIN



- ACCESSORIES AND SPARE PARTS FOR E044N
- SPARE PARTS:
- E046N** 1,13 mm. Ø hardened needle (EN 196-3:2005)
 - E046-01N** 1 mm. Ø hardened needle (ASTM)
 - E055-05** Plastic mould Ø 60/70 x 40 mm. high following ASTM
 - E055-07** Glass base plate
 - E055-10** Plastic mould Ø 70/80 x 40 mm. high following EN, NF
 - E042-06N** Probe 300 g to EN 196-3:2005
 - E044-48N** Tang to fix the needle to the probe
 - C127-11** Thermo-paper roll for printer (pack of 10 rolls)



SETTING TIME AND CONSISTENCY OF CEMENT

E050

Automatic recording penetrometer "Italcementi model" *

Used for determining the initial and final setting time of hydraulic binders.

This instrument automatically measures and records the time needed by a cement paste to reach a pre-established consistency degree.

The setting of the specimen is measured in static conditions; it is continuously and automatically recorded on a diagram allowing an accurate and uniform determination of the initial, intermediate and final hardening process.

The operator obtains a graph with the results of each tested specimen, accurately showing the progressive increasing of the consistency-time ratio (consistogram).

The instrument automatically cut-off at the end of the test.

* NOTE

This Penetrometer has been expressly manufactured on specific request of "Italcementi group" cement factory.

THE PENETROMETER IS SUPPLIED COMPLETE WITH:

- two penetration needles
- two plastic moulds dia. 70/80 h 40 mm complete with base and humidity hopper
- two writing ink pens
- 100 recording diagrams

Power supply: 230V 1ph 50Hz 100W

Dimensions: 450 x 185 x 370 mm

Weight : 22 kg



E050

LOSS-ON-IGNITION OF CEMENT AND BUILDING LIME, AND CONTENT OF CHLORIDE, CARBON DIOXIDE AND ALKALI INTO THE CEMENT

STANDARDS: EN 196-2 / EN 196-21 / EN 459-2

A muffle furnace is used to oxidize the sample in air at 975 ± 25 °C.

Technical details: see mod. A024, pag. 28 section Aggregates.



A024

E059

Funnel groove

CONSISTENCY OF GROUTS

STANDARDS: EN 13395-2 / UNI 8997

Used to determine the consistency of the expansion premixed cement mortars for anchorages, mixed with water, classified of super-fluid type. Supplied complete.

Weight: 20 kg



E059

E060



E060-01

E060-03

DETERMINATION OF THE FREE EXPANSION IN PLASTIC PERIOD,

and of the exudation quantity of the mixing water on expansion premixed mortars for anchorages, mixed with water.

STANDARDS: UNI 8996, 8998

The equipment consists of:

E060 Bridge of dual measure, formed by a steel square straightedge with two adjustable measure screws

E060-01 Fix caliper at two steps, having heights of 100 and 107 mm

E060-03 Metallic container dia. 99x120 mm with 3 hermetic covers



**E061N
CALORIMETER**

HEAT OF HYDRATION OF CEMENT

STANDARDS: EN 196-8 / ASTM C186

Comparable to: BS 4550, 1370 / UNE 80102, 7105
DIN 1164 / UNI 7208

Used to determine the heat of hydration of low heat Portland and hydraulic cement.

The apparatus consists of a Dewar flask contained in an insulated material and housed in a wooden box which is hinged so that the flask can be easily removed or replaced.

A "second" hinged wooden box contains the first one, granting a better insulation, as expressly requested by the a.m. Standards.

The Calorimeter is supplied complete with a constant speed electric stirrer, and filler glass funnel.

The standard supply "does not include":

- the thermometer (to be selected from Beckman or digital model; see accessories)
- the propeller (selecting it from the specific Standard; see accessories)

which must be ordered separately.

Power supply: 230V 1ph 50Hz 150W

Dimensions: 350 x 250 x 680 mm

Weight : 12 kg approx.

"NEEDED" ACCESSORIES:

E062-02

BECKMAN centesimal glass mercury thermometer, or:

E062-04

DIGITAL THERMOMETER. Resolution: 0,01°C.

Complete with probe, or:

E062-04N

DIGITAL THERMOMETER. Resolution: 0,001°C.

- Memory for 10000 readings
- Displays, stores and prints: min, max, mean values, delta T
- Alarm if limit values are exceeded
- Battery operated

E061-11

PROPELLER, conforming to ASTM C186 Specifications, or:

E061-12

PROPELLER, conforming to EN 196-8 Specifications.

ACCESSORY:

V300-19

Paraffin wax with melting point 55°C to coat the glass parts which are in contact with the hydrofluoric acid.
Pack of 5000 g.

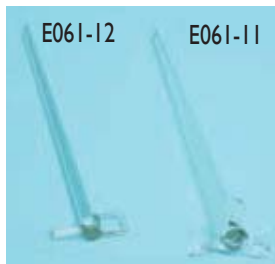

E062-02



E061N OPEN

SPARE PARTS:

E062-01 Dewar flask

E062-03 Filler glass funnel

E062-10

Langavant calorimeter

STANDARD: EN 196-9

Used to measure the heat of hydration of cements by means of semi-adiabatic method.

The equipment consists of:

Testing calorimeter, calibrated, dia. 160 by 350 mm

Reference calorimeter (same of the testing one), without certificate. 50 mortar box and 20 sand bags.

Measuring system complete with two temperature probes, modem, software to record temperature, analyze and display data with wireless transmission to modem.

To perform the test a PC is required



E062-10



E070

Autoclave

SOUNDNESS (EXPANSION) OF PORTLAND CEMENT

STANDARDS: Comparable to ASTM C151, C490 / AASHTO T107

It consists of a high pressure boiler made from special alloy steel, inside dia. mm. 154x430 high, receiving a holding rack for 10 cement specimens. The heating system is achieved by electric resistances.

The separate control panel encloses a "digital thermometer" to visualize the boiler temperature, pressure gauge scale 0 - 600 psi with built in pressure regulator and power switches.

Supplied complete with rack for holding the specimens and safety valve with PED Cat. certificate according to the 97/23/CE Standard. Not sellable on CE market.

Power supply: 230V 1ph 50 Hz 3500 W 295 psi

Dimensions: 450x475x1080 mm

Weight: 75 kg

MOULDS FOR SOUNDNESS (EXPANSION) AND SHRINKAGE TESTS (with length comparators, see next page)

Available models:

E072

STANDARD: ASTM C490

TWO GANG PRISM MOULD to produce 25x25x250 mm specimens for expansion tests in autoclave.

Complete with 4 steel inserts. Weight: 6 kg

E073

STANDARD: BS 1881, 6073

TWO GANG PRISM MOULD to produce 75x75x254 mm specimens. Complete with 4 steel inserts. Weight: 9 kg

E072-01 CONTACT POINTS stainless steel, spare for E072 and E073 moulds. Pack of 10 pieces.

E075

Three gang prism mould to produce 40,1x40x160 mm mortar specimens

STANDARD: EN 12617-4

Comparable to: ASTM C438, NF P15-433

Used for the determination of linear shrinkage of cement mortar. Manufactured from steel with hardness over 200 HV.

All surfaces are grinded and all parts are marked with an identification number for a correct assembling.

A part-number is engraved on each mould and a Certificate of Conformity is supplied along with.

Complete with 6 steel inserts and fixing screws.

Weight: 8,600 kg

SPARE PART:

E075-01 CONTACT POINTS, stainless steel, complete with fixing screw. Pack of 12

ACCESSORIES:

E075-10

STANDARD: EN 12808-4

SPACER, teflon made, dimensions 15x40x160 mm to put into the chamber of the E075 mould, to produce 10x40x160 mm specimens for shrinkage tests as per EN 12808-4 Standard.

Pack of 6 spacers.

E075-11

INSERTS, for the 10x40x160 mm specimen.

Standard: EN 12808-4

Pack of 12 inserts.

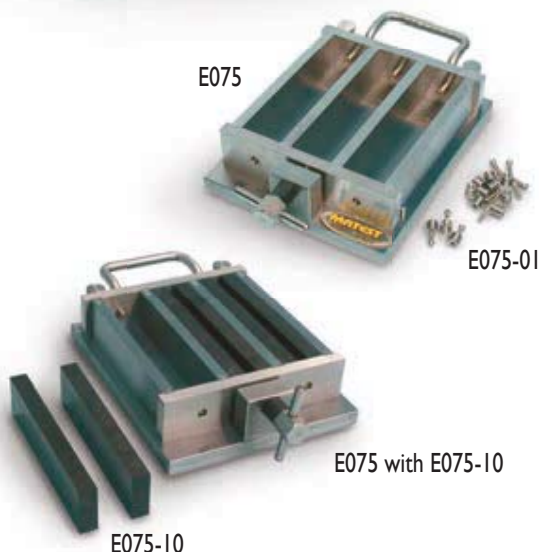

E107

STANDARDS: NF P15-434 / DIN 1164

THREE GANG PRISM MOULD to produce 40x40x160 mm specimens. Made from steel 55 HRB. Complete with 6 inserts. Weight: 8 kg



E113

STANDARD: NF P18-427

THREE GANG PRISM MOULD to produce 70x70x280 mm specimens. Made from steel 55 HRB. Complete with 6 inserts. Weight: 17 kg

E107-01

E107-01 CONTACT POINTS, spare for E107 and E113 moulds. Pack of 12 pieces.

Length comparator

STANDARDS: EN 12617-4, 1367-4, 12808-4 / ASTM C151, C490, NF P15-433, P18-427 / BS 1881:5, 6073 / DIN 1164

Used to measure the length variations of mortar specimens after autoclave soundness tests. The top beam is adjustable to suit the specimen's length.

It also measures the linear shrinkage of specimens having different dimensions like:

- 40x40x160 mm EN 12617-4, EN 12808-4, ASTM C348, UNI 6687, NF P15-433, DIN 1164
- 25x25x250 mm ASTM C490
- 70x70x280 mm NF P18-427
- 75x75x254 mm BS 1881, 6073
- 50x50x200 mm EN 1367-04

Supplied "without reference rod" (see accessories)

Dimensions: dia. 180 x 450 mm

Weight : 10 kg

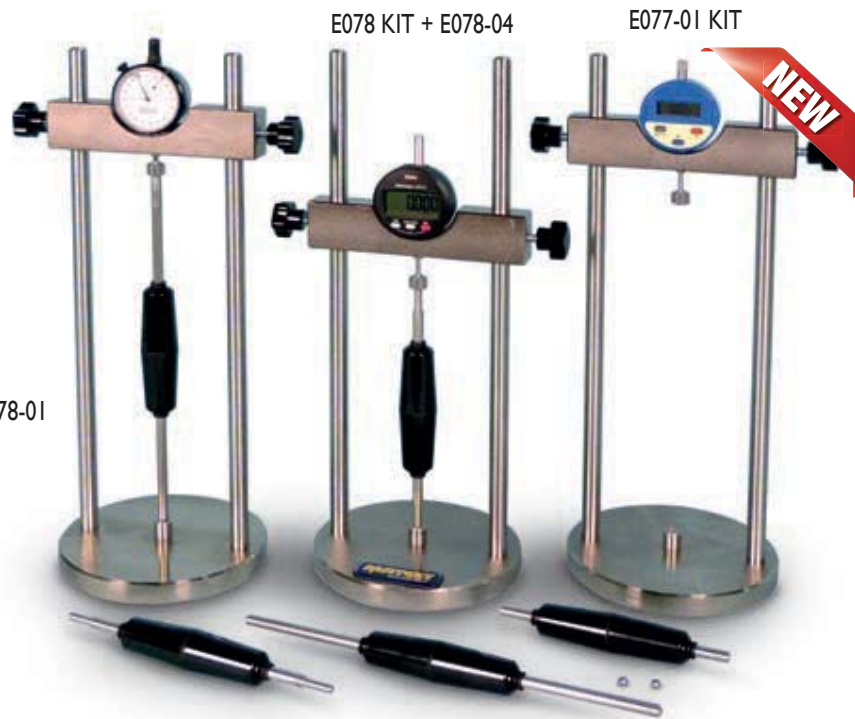

E077 KIT + E078-01

AVAILABLE MODELS:

E077 KIT

LENGTH COMPARATOR with Analogic Dial Indicator, 5 mm travel by 0,001 mm divisions, mod. S375

as an alternative:

E077-01KIT

LENGTH COMPARATOR with Digital Gauge 15,3 mm travel by 0,001 mm divisions mod. S382-02, complete with battery, but "without" RS232 port

as an alternative:

E078 KIT

LENGTH COMPARATOR with Digital Gauge 12,7 mm travel by 0,001 mm divisions mod. S382-01, complete with battery and RS232 connection to PC.

ACCESSORY for mod. E078 KIT :

S382-13

Software, complete with USB adaptor and connection cable to PC.

ACCESSORIES for E077 KIT, E077-01 KIT and E078 KIT:

E078-04 Reference rod, Invar, for 40x40x160mm specimens Standards: EN 12617-4, EN 12808-4, NF P15-433

E078-01 Reference rod, Invar, for 25x25x250mm and 75x75x254mm specimens. Standards: ASTM C490, BS 1881, UNI 8520

E078-03 Reference rod, Invar, for 70x70x280 mm specimens Standard: NF P18-427

E078-06 Reference rod, Invar, for 50x50x200 mm specimens Standard: EN 1367-04



SOUNDNESS OF CEMENT AND LIMES

STANDARDS: EN 196-3 / EN ISO 9597 / BS 6463 / NF P15-432
UNE 80102

E064

Le Chatelier water bath

Constructed with stainless steel inside chamber and exterior case in painted steel sheet, it can hold up to 12 Le Chatelier moulds (to be ordered separately) in the removable rack, supplied with the bath.

The bath reaches the boiling point in approx. 30 minutes. Now an original device keeps the bath temperature at the boiling point, by avoiding the water evaporation and assuring that Le Chatelier moulds remain covered by the water during all the test execution.

Power supply: 230V 1ph 50/60 Hz 1800 W

Dimensions: 405x265x205 mm

Weight: 7 kg

E065

Le Chatelier mould individually tested

Similar to mod. E066, but with pointers bigger sized, granting a higher number of test utilisations (about 10 times more) within the tolerances requested by EN Specifications.

“Chromed finishing”.

The moulds are checked one by one with engraved a serial number for an easier identification of each mould, they perfectly meet EN 196-3 Specification.

E066-01

Glass plate 50x50 mm to cover the mould. Pack of 2 pieces.

E066-02

Weight: 100 g to be placed over the glass plate.

E066-03

Extensibility of mould apparatus to check the elasticity of the split cylinder of the mould. Complete with 300 g weight.

E066-04

TAMPING ROD 17 mm dia.

Weight: 70 g.

section E



322



E064
with E065

Rack detail with E065

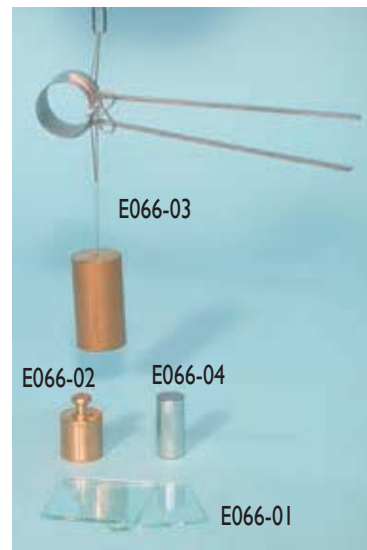

E066-03

E066-02

E066-04

E066-01

E066

Le Chatelier mould

Made from a brass spring tensioned split cylinder having internal dia. 30 by 30 mm high, with two pointers 150 mm long.

“Chromed finishing”.

Used to determine the cement expansion (soundness) eighter in cold and in boiling water.

Weight: 30 g

E082

Pat test

SOUNDNESS OF HYDRATED LIME AND GYPSUM PLASTERS

STANDARDS: EN 459-1 / BS 890, 1191

Utilized for the determination of the soundness of hydrated lime, gypsum and building plasters.

Consisting of a brass ring mould, 100 mm. diameter by 5 mm deep.

The mould has an inside taper of 5°.

Supplied complete with glass base plate.

To carry out one test, three moulds are required.



E082



E066

E065

E083**Plunger penetration apparatus**

CONSISTENCY OF MASONRY CEMENT
AND BUILDING LIMES

STANDARDS: EN 413-2, 459-2, 1015-4
DIN 4211

Used to determine the consistency of fresh mortar, lime and masonry cement.

The base is foreseen of a device to locate the test cup.

The height of the drop can be accurately adjusted to 100 mm.

Supplied complete with test cup and tamper; both anodized aluminium made

Dimensions: 200x200x700 mm

Weight: 8 kg

E083

**E081****Mortar workability apparatus**

STANDARDS: EN 413-2 / NF P18-452

Designed to test concrete mortar for dynamic workability and also to ensure optimum proportioning of mortar constituents (sand, water, cement, as well as cement/sand and water/cement ratios) compatible with given application. Suitable also for checking possible improvement when admixing a plastifier, or for comparing two mortar types. The unit consists of a prismatic receiver divided into two unequal volumes by a removable partition, and by an electric vibrator. The fresh mortar is poured in the large volume place, the separating partition is removed and the vibrator starts automatically. As a result of vibrations, mortar flows from the large volume to the small one, in a time which is a function of the workability of the mortar. Power supply: 230V 1ph 50 Hz 110W

Dimensions: 400x200x200 mm

Weight: 18 kg



E081

E082-01**Water retention**

STANDARDS: EN 413-2

Brass chromed mould having dia. 100 mm by 25 mm deep, it is used for determining the water retention of masonry cements.

Weight: 300 g approx



E082-01

Methods of test for mortar for masonry**E082-11****CIRCULAR TEST CONTAINER**

STANDARD: EN 1015-19

Used to determine the water vapour permeability of hardened rendering and plastering mortars.

Manufactured from PVC material, resistant to corrosion, it has an opening of approx. 0,02 sq.mt., on which the test sample is sealed

Dimensions: dia. 240 mm by 60 mm

Weight: kg approx.

E082-11

**E081-10****Steam Bath**

SOUNDNESS OF BUILDING LIME DETERMINATION

STANDARD: EN 459-2

This bath is used for the determination of the soundness of building limes subjected to steam action at atmospheric pressure for 180 minutes time.

The steam bath, all stainless steel made, holds up to 12 Le Chatelier moulds, approx. 50 mm over the water level.

Two heating elements of 1200W and 200W reach the water boiling point in 30 minutes; now a timer disconnects the 1200W element, and the water temperature is maintained by the second element, as requested by the Standard.

The cover has a device avoiding the condensed water to drop on the specimens.

Power supply: 230V 1ph 50/60Hz 1400W

External dimensions: 455x215xh350 mm

Inner dimensions: 300x150xh260 mm

Weight: 9 kg approx.

ACCESSORIES:

E066 LE CHATELIER MOULD Technical details : see pag. 322

E066-01 GLASS PLATE, 50x50 mm. Pack of 2 pieces.

E066-02 WEIGHT, 100 g.

E066-03 EXTENSIBILITY of mould apparatus.

E066-04 TAMPING ROD, 17 mm dia x 70 g weight.



E081-10



Products and systems for the protection and repair of concrete structures. Determination of stiffening time

STANDARD: EN 13294

Methods of test for mortar for masonry. Determination of workable life and correction time of fresh mortar

STANDARD: EN 1015-9

E083-10

Lever Support (drill-holder type), complete with washer and penetration rod brass made, clamp and locking support.

Used for the determination of stiffening time on products and systems for the protection and repair of concrete structures. Complete with container. Dimensions: 380 x 300 x h 500 mm Weight: 12 kg approx.



E083-10

SPARE PARTS:

E083-11

CONTAINER, rigid aluminium made, dia. 90 by height 60 mm, complete with cover.

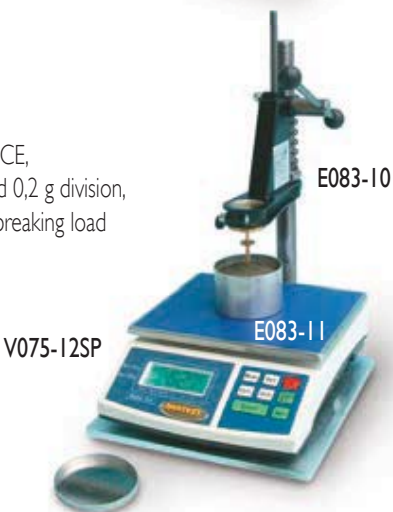

V075-12SP

ACCESSORY:

V075-12SP

DIGITAL BALANCE, 15 kg capacity and 0,2 g division, with hold of the breaking load and with tare..



E083-11

E067

Cracking test mould

STANDARD: NF P15-434

Used to produce ring-shaped specimens designed for cracking tests on hydraulic binders. This test consists of measuring the formation time of a crack on the test specimen. Weight: 8 kg



E067

E067-05

Mortar bar container

STANDARD: ASTM C227

This test method covers the determination of the potential alkali reactivity of cement-aggregate combinations (mortar bar method).

The device is composed by an acrylic cylinder container with a stainless steel rack. Dimensions: 170mm dia. x 450mm Weight: 3 kg approx.

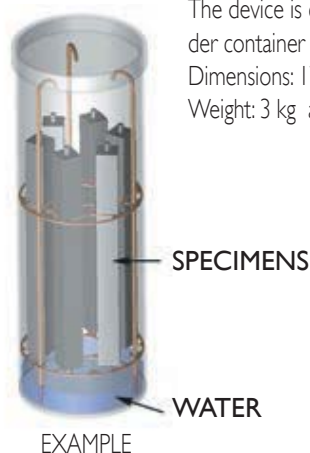

EXAMPLE



E067-05

E080

Plaster extensometer

STANDARDS: BS 1191 / UNI 6782

Utilized to measure the linear expansion of a paste of standard consistence. The extensometer comprises an horizontal cradle 100 mm long x 60 mm wide x 25 mm deep closed at one end and open to the other. The open end is in contact with a dial gauge spindle, so that the lateral expansion of the specimen is measured. The dial gauge has 10 mm travel and 0,01 mm. graduation. Dimensions: 250x80x80 mm Weight: 3 kg



E080

A105

Calcimeter, (Gasometer) Dietrich-Frühling CARBONATE CONTENT CaCo³ IN LIMESTONE AND LIME MARL

It mainly consists of a glass container in which the reaction between the calcium carbonate present in the product and a solution of hydrochloric acid takes place.

The gased product is collected and measured by a device connected to the container.

As the volume of the produced gas (Co²) is in relation to the CaCo² amount contained in the material, it is possible to calculate the percentage of CaCo³ Dimensions: 400x200x1100 mm. Weight: 13 kg



A105



FLOW TABLES

FOR FLOW AND WORKABILITY TESTS OF MORTAR AND LIME

STANDARDS: EN 459-2, EN 1015-3 / ASTM C230 / *comparable to BS 4551-1

To perform this test, a specimen contained in a cone mould is placed on a metal surface which is then raised and dropped from a known height, after releasing the specimen from the mould.

The equipment consists of a circular top table with spindle, tripod, bronze flow mould and tamper. The apparatuses to EN Standards are equipped also of a filling hopper. Motorized models foresee an automatic digital drop counter.

The flow tables mod. E090 KIT and E090-01 KIT meet to both the EN 459-2 and EN 1015-3 Specifications.

Power supply (motorized models): 230V 1ph 50 Hz 150W

Weight: 25÷60 kg



E090 KIT



E090-01 KIT

ACCESSORIES :

E087-01

FLOW CALLIPER to ASTM and BS Standards, for measuring the diameter of the sample. Brass made.

Weight: 450 g.



E087-01



E086 KIT



E087 KIT



E090-08

E090-08

FLOW CALLIPER to EN 459-2 and EN 1015-3 Specifications.

SPARE PART:

E085-07

FILLING HOPPER to the mould.
Standard: EN 459-2.

Model	Standard	Operated Hand	Motorized	Table dia. mm	Drop height mm	Spare mould	Spare tamper
E086 KIT	ASTM C230 *(BS4551-1)	•		254	12,7	E087-05	E087-06
E087 KIT	ASTM C230 *(BS4551-1)		•	254	12,7	E087-05	E087-06
E090 KIT	EN 459-2 EN 1015-3	•		300	10	E085-05	E085-06
E090-01 KIT	EN 459-2 EN 1015-3		•	300	10	E085-05	E085-06



E092N KIT

MIXMATIC “HIGH PERFORMANCE TOUCH SCREEN”

AUTOMATIC PROGRAMMABLE COMPUTERIZED MORTAR MIXER

STANDARDS: EN 196-1, EN 196-3:2005, EN 413-2, EN 459-2, EN 480 / NF P15-314 / EN ISO 679 / DIN 1164-5, DIN 1164-7
ASTM C305 / AASHTO T162

section E



326



E092N KIT

Design :

- Very sturdy and durable construction for intensive laboratory use.
- Planetary transmission for silent and low maintenance operation.
- Automatic sand dispenser having dimensions and geometry to grant the correct sand insertion, without residual and disaggregation between fine and coarse portions.
- Dispenser for additives (see accessory mod. E092-05).
- Dispenser for automatic water addition (see accessory mod. E092-06).
- Transparent CE-conform protection of the mixing area, to allow the mixture looking during the test.
- Digitally controlled rotation speed.
- Complete with stainless steel polished beater and mixing bowl.
- Easy and fast bowl insertion and removal.
- Safety system of bowl presence and correct position to avoid dangerous working, with double sensor of removed bowl with load/unload sequential discrimination.
- Emergency stop button.

Firmware:

- Different automatic programmable mixing cycles conforming to the a.m. Standards.
 - The operator can also program up to 30 automatic personalized mixing cycles, easy to set through Touch Screen.
 - Synchronised acoustic signals with cycle steps.
 - Electronic control unit with touch screen colour display, that runs like a standard PC based on Windows operating system for the management and analysis of the data, test results, graphs. The touch-screen icon interface allows an easy set up of the parameters and immediate execution of the test. Direct connection to Intranet (connection to a LAN network) and Internet to establish a remote communication and receive an immediate diagnostic analysis of the potential problem from Matest technicians, or for updates of the software.
- Hardware technical details: see pag. 24
Unlimited memory storage with: 2 USB ports, 1 SD card slot, RS232/485 serial port.
- Rotational motor feeded through inverter to grant the max. precision of the rotational speed, adjustable by the operator on the display.
 - Possibility of manual mixing cycle.
 - Possibility to select different languages.

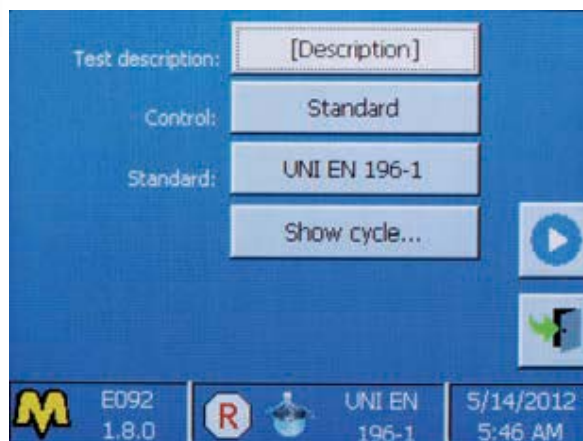

Selection of the Standard

- Detailed indication of all the times (elapsed from the test start, residual to end test, elapsed from and test and bowl removal), state of cycle development with analogue bar, speed, active phase (sand, water), test state (correct execution or test interruption with lost results), type of current test.

Power supply: 230V 50/60 Hz 1ph
Dimensions: 530 x 620 xh 780 mm
Weight : 85 kg

E092N KIT MIXMATIC ...follows...



Test execution

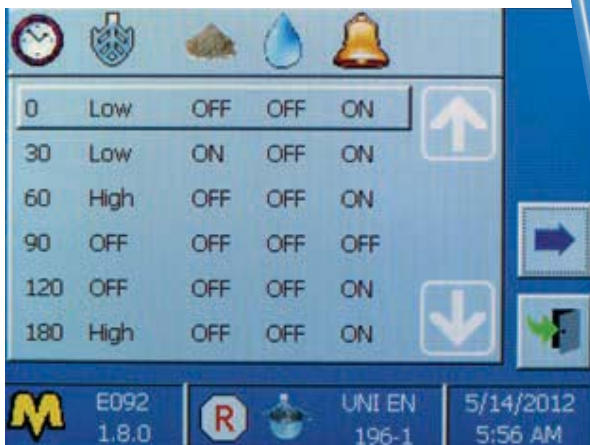

Personalized cycle composition



ACCESSORIES :

E092-05
 DISPENSER (supplementary) with hopper to ease the manual introduction of additives etc. into the bowl, also during the mixing phase.

E092-06
 DISPENSER (supplementary) with hopper for the automatic introduction (managed by the software) of water into the bowl, also during the mixing phase.

E097-01N Reference sand, size 0,08÷2 mm to EN 196-1 Standard.
 Bag of 1350 g. Pack of 16 bags for total of 21,6 kg.



SPARE PARTS:

E092-10 BOWL, stainless steel 4,75 litre capacity.

E095-04 BEATER, polished, stainless steel.



USE EXAMPLE



... follows...



MORTAR MIXERS

STANDARDS: EN 196-1, EN 196-3:2005, EN 413-2, EN 459-2,
EN 480-1 / EN-ISO 679 / NF P15-314 / DIN 1164-5
UNE 80801 / ASTM C305M / AASHTO T162

section E



328



E093 + E095-03

MODELS:

E093

Automatic mortar mixer

This very robust mixer is expressly designed for the efficient mixing of cement pastes and mortar, with "four" automatic sequences of mixing cycle, in compliance with:

EN 196-1, EN 196-3:2005, EN 480-1, ASTM C305M Specifications.

Bowl capacity is 4,7 litres

Two speeds can be selected:

140 or 285 rpm for the revolving action

62 or 125 rpm for the planetary action

It is possible to select the manual working, or one of the two automatic programs.

By operating automatically on changes of speed, stops and mixing sequences, outlined by acoustic signal, the unit performs the mixing cycle.

The unit is equipped of an automatic sand dispenser which fills the sand into the mixing bowl for a period of 30 seconds (EN 196-1 program). Complete with safety door conforming to CE Safety Directive; if opened it automatically stops the machine.

Supplied complete with stainless steel bowl, bajonet coupling between beater and shaft, but "without beater" which has to be ordered separately (see mod. E095-03 or E095-04).

Power supply: 230V 1ph 50 Hz
Dimensions: 340x460x700 mm.
Weight: 45 kg

Power supply: 230V 1ph 50 Hz

Dimensions: 340x460x700 mm.

Weight: 45 kg

E094

Mortar mixer

Basically similar to mod. E093, but not equipped of automatic program, sand dispenser and safety door.

Two speeds can be selected. Supplied complete with stainless steel bowl, but "without beater" which has to be ordered separately.

This mixer can be supplied only to extra CE markets

Dimensions: 340x460x500 mm

Weight: 40 kg



E094

E095

E095

Mortar mixer

Basically similar to mod. E094, but complete with sand dispenser and safety door to CE Safety Directive.

Two speeds can be selected. Supplied complete with stainless steel bowl, but "without beater" which has to be ordered separately.

Dimensions: 340x460x500 mm

Weight: 44 kg

ACCESSORIES FOR E093, E094, E095 MIXERS:

E095-03 Stainless steel beater with bayonet fittings.

E095-04 Stainless steel beater with bayonet fittings.

The beater is accurately polished to eliminate the porosities.



E096-01

E096-01

Dispenser with hopper, to ease the manual introduction of water, additives etc. into the bowl also during the mixing phase. Accessory to mod. E093 and E095 mixers.

E097-01 Reference sand, size 0,08÷2 mm to EN 196-1 Standard.

Bag of 1350 g. Pack of 16 bags for total of 21,6 kg.

SPARE PARTS FOR E093, E094, E095 MIXERS:

E095-01

Stainless steel bowl

E095-05

Bajonet coupling between beater and shaft



E095-03

E095-05

E095-05

E095-05

E097-01

E095-01

E095-04

E095-04



section E



329

MATEST

EI42

DIGITAL "PULL-OFF" (BOND) STRENGTH TESTER. CAPACITY: 16 kN

STANDARDS: EN 1542, EN 1348, EN 1015-12, EN 13687-2, EN 13963, EN 14496 / NF P18-858 / BS 1881:207 / ISO 4624

This dynamometer measures the adhesive force and the tensile strength of two layers of materials (concrete, facing plasters, mortars, building plasters, lime etc.) and is particularly suitable for applications concerning testing repairs of any structure where the bond strength between two layers is an essential factor.

Compact, light, for use in any location, this Pull-Off Tester is fitted with a load cell and high resolution large digital display unit; it is therefore suitable for measurements from low loads up to 16 kN, granting a wide working range and ideal for a large number of applications and materials. The direct tensile force is applied by rotating the hand wheel.

The three feet of the unit can be fixed in the "large" position (overall dimensions 176mm diameter; see drawing "A") with very stable bearing, or in the "compact" position (overall dimensions 92,5mm diameter; see drawing "B"), to perform tests in narrow spaces, or for specimens close one to the other.

section E

Specifications:

- Load capacity: 16 kN
- Resolution: 10 N
- Working range: 0,25 to 16 kN
- Accuracy and repeatability: better than +/- 1%
- Complete with traceable calibration certificate
- Battery operated
- Serial port for PC connection
- Hand wheel rounds: 60 with mechanical round/counter
- Graphic indication of the applied load rate
- Seat ball assuring axial/central load application

Supplied complete with carrying case, but "WITHOUT" accessories to perform the test, which have to be ordered separately.

To perform the test a common electric drill is required.

Dimensions: 410 x 210 x 270 mm

Weight : 3,5 kg approx.



330



EI42 with feet in large position

EI42-01 Pull-Off "Digital" tester 0-5 kN capacity

Identical to mod. EI42 but with load cell and digital display range 0-5 kN for more accurate measurements on low strength values



EI42 in aluminium case

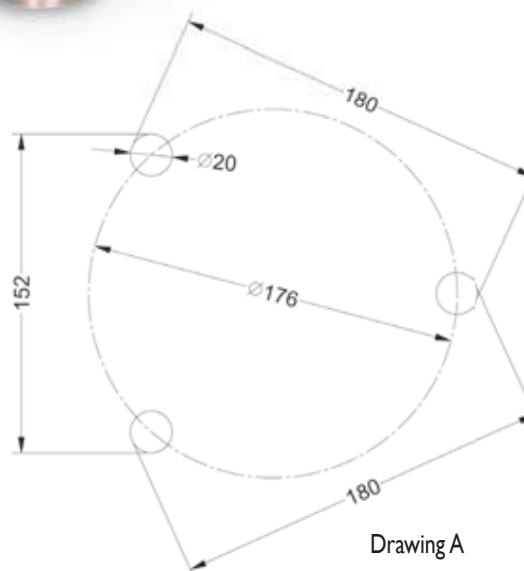

Drawing A

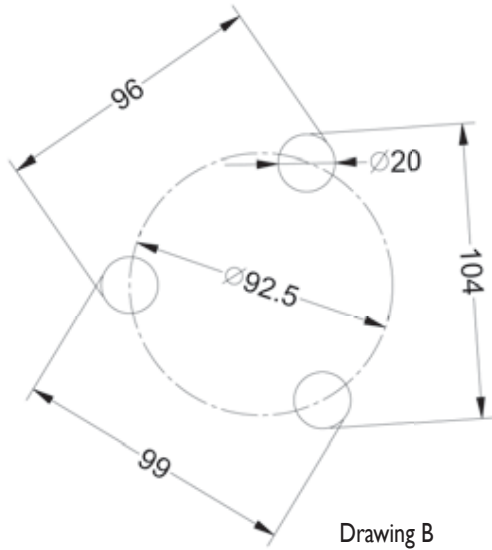

Drawing B



E142
with feet in compact position

section E



331

ACCESSORIES:

E142-10 SOFTWARE complete with connection cable to download test results to the PC

E143 Adhesion test aluminium disc 20 mm dia. by 20 mm thick (n° 10 pieces)

E143-01 Adhesion test aluminium disc 50 mm dia. by 31 mm thick (n° 10 pieces)

E143-10 Adhesion test stainless steel disc 50 mm dia. by 21 mm thick (n° 10 pieces) It conforms to EN 1015-12 Specification.

E143-13 Adhesion test aluminium disc, square, 50x50mm, 20mm thick (n° 10 pieces)
Standard: EN 1348

E143-11 Cylindrical ring, having truncated cone shape, inside dia. 50 mm
Standard: EN 1015-12

E143-02 Drill bit with centering bit, 20 mm diameter, for the preparation of the test surface.

E143-03 Drill bit with centering bit, 50 mm diameter, for the preparation of the test surface.

E143-12 Acrylic adhesive glue, 300 ml. cartridge, complete with small pump and nozzles.



E143-13

SPARE PART:

E143-09 Tie rod with spheric head for Disc/Dynamometer coupling.



MATTEST

E102

Three gang mould for 40,1 x 40 x 160 mm prisms

STANDARDS: EN 196-1 / EN ISO 679

Manufactured from steel with "hardness of inside walls over HV 200", it meets the dimensional tolerances to EN 196/1 Standard. All surfaces are grinded and all parts are marked with an identification number for a correct assembling. A part-number is engraved on each mould and a Certificate of Conformity is supplied along with. Weight: 8560 g.



E102

E103

Three gang verified mould for 40,1 x 40 x 160 mm prisms

STANDARDS: EN 196-1 / EN ISO 679

Identical in shape to mod. E102, but manufactured from heavy duty steel "with hardness of inside walls over HV 500" (EN196/1 Specifications recommend hardness HV 400). This high hardness value keeps the mould within the tolerances requested by Spec. for many tests, granting very long utilisation life.

All parts are marked with an identification number for a correct assembling. Each mould is individually verified in the dimensional tolerances, hardness, squareness, flatness and roughness with instruments periodically certified by Namas Centre or equivalent. A part-number is engraved on each mould, and a Certificate of Conformity is supplied along with. Weight: 8560 g.

E103
DETAIL



E102-11

Six gang mould for 40,1 x 40 x 80 mm

DETERMINATION OF WATER ABSORPTION on grouts for floor or wall installation of ceramic tiles.

STANDARD: EN 12808-5

Identical to mod. E102, but equipped with three stainless steel partitions, positioned in the middle of the gangs, to obtain six gangs having dimensions 40,1 x 40 x 80 mm approx.

Weight: 8600 g

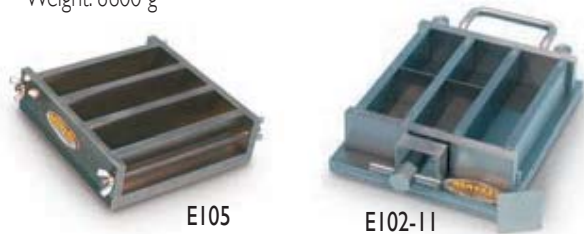

E105

E102-11

E104

Three gang verified mould for prisms 40,1 x 40 x 160 mm "Italcementi model"

STANDARD: EN 196-1

Similar to mod. E103, but with:

- Large base mm 240 x 245
- Weight: 11,850 kg

Manufactured expressly for "Italcementi Group" cement factory.

E105

Three gang mould for prisms 40x40x160 mm

STANDARDS: NF P15-413 / ASTM C348 / DIN 1164, 1060

Made from steel, hardness 55 HRB, it conforms to the above mentioned Specifications. Weight: 8 kg

ACCESSORIES:

E106 FEED HOPPER, used to fill the mould E102, E103, E105 when it is mounted on the Jolting machine E130, E131
Made from cast aluminium. Weight: 1 kg.

E102-02 LARGE AND SMALL SCRAPER to EN 196-1-2005

S200-11 STRAIGHT EDGE 300 mm. long

E102-03 GLASS PLATE 220x190x6 mm to cover the mould

E112

Three gang mould for 70,7x70,7x282,8 mm

STANDARD: NF P18-401

Made from steel. Weight: 17 kg

E111

Briquette mould

STANDARDS: ASTM C190, C307 / AASHTO T132

Accurately machined it conforms to the above Specifications and is easily collapsible. Complete with base.

Weight: 3 kg



E112

E110

E110

50 mm three gang cube mould

Made from steel, hardness 55 HRB, it can be also used for soil and other materials. Weight: 7 kg

E111



E102-03

E106

S200-11

E102-02

E130
Jolting apparatus

STANDARDS: EN 196-1 / EN ISO 679 / NF P15-412 / BS 3892 / UNE 80101

Used to compact cement mortar prisms 40x40x160 mm in the three gang mould, as requested by the above Specifications.

The apparatus, consists of a table holding the mould, seated on a rotating cam driven at 60 revolutions per minute. The jolting group is connected to the table by bayonet joints for quick checking of the weights.

The drop height (15,0 mm) is adjustable to keep it correct also after intensive uses. The apparatus is supplied with separate control panel including main switch, automatic digital drop counter, start/stop push button.

The apparatus accepts moulds Matest made, and also of other manufacturers.

Power supply: 230 V 1ph 50 Hz 500 W

Dimensions: 1000x380x420 mm

Weight: 65 kg

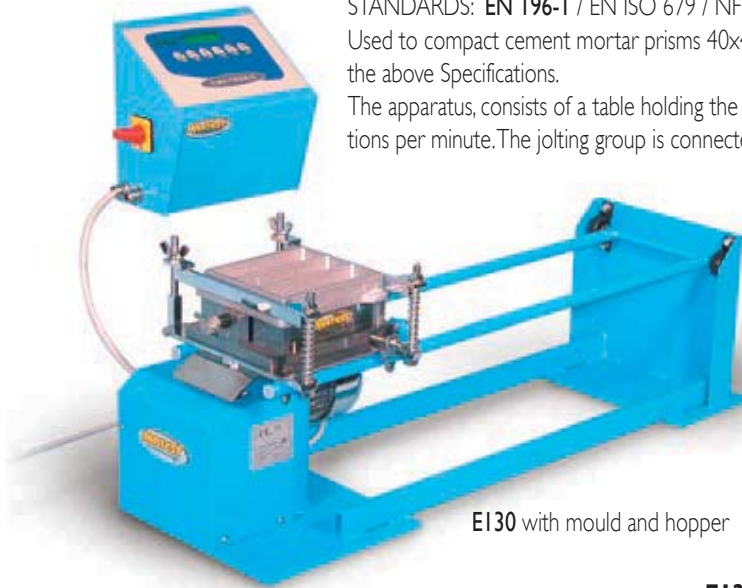

E130 with mould and hopper

E130-II

Cabinet, manufactured from sheet steel, internally lined with sound-proofing material for noise reduction, to be used with the Jolting apparatus E130, E131. Front opening with rear hinges and jacks to facilitate the lifting.

Concrete base minimum 1350 x 670 mm is requested.

Dimensions: 1300 x 510 xh 700 mm

Weight: 25 kg



E130-II + E130

E131N
Jolting apparatus "high performance"

STANDARDS: EN 196-1 / EN ISO 679

Similar to model E130, but manufactured with oversized components, treatments and extremely accurate couplings for intensive use in heavy conditions.

Motor feeded by an inverter to grant the keeping of 60 revolutions per minute in any condition.

Power supply: 230V 1ph 50/60 Hz 500 W

Weight: 93 kg

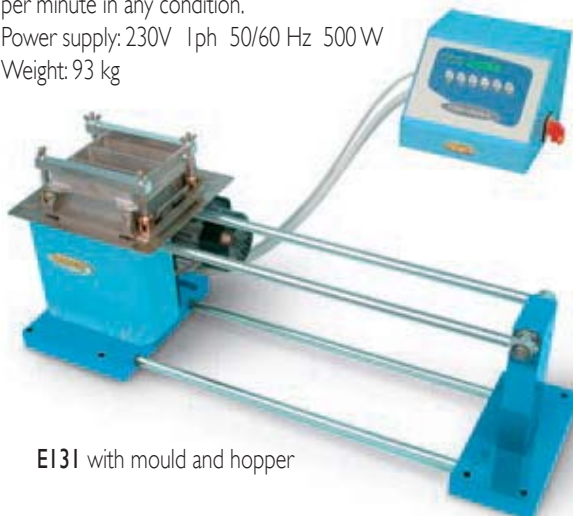

E131 with mould and hopper

E132

Vibrating machine for 70,7 mm cube moulds

STANDARD: BS 4550

The mould is mounted on a vibration platform with excentric mechanism. The machine is supplied complete with separate control panel with timer; but "without cube moulds" to be ordered separately. Power supply: 230V 1ph 50 Hz 250 W

Weight: 100 kg



E132 with mould

E133

Cube mould 70,7 mm

STANDARD: BS 4550

Made from steel with dimensions as specified by above Standard.

Complete with base plate (three moulds required for each test).

Weight: 3 kg

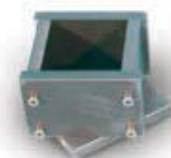

E133



WATER BATHS FOR CEMENT CURING AND FOR GENERAL LABORATORY PURPOSE

STANDARDS: EN 196-1, 196-8 / EN ISO 679 / ASTM C109, C511

Double walled all stainless steel made, with wool insulation and water circulation electric stirrer; the bath ensures an uniform and constant temperature.

Temperature range: from ambient to +60°C. with accuracy of +/- 0,4°C. at 20°C.

The bath is equipped with digital thermostat and a dual safety thermostat with higher thermic threshold ensuring safe working conditions.

A cooling coil device to be connected to the water net is used when room temperature exceeds the requested one, with possibility to reduce the bath temperature within the room and water net conditions.

The specimens are held by a perforated shelf spaced from the bottom.

MODELS:

EI36

Water bath, 40 litres capacity

It can hold over 60 specimens 40,1x40x160 mm

Internal dimensions: 510x350x230 mm

Overall dimensions: 680x420x420 mm

Power supply: 230V 1ph 50/60Hz 1200W

Weight: 28 kg approx.

EI36-01

Water bath, 200 litres capacity

Internal dimensions: 900x600x360 mm

Overall dimensions: 1050x680x430 mm

Power supply: 230V 1ph 50/60Hz 4000W

Weight: 55 kg approx.

B052-02

Water bath with cooling device

Similar to mod. EI36, but with temperature range: +3 to +95° C.

Accuracy of ± 0,4° C at 20° C.

The cooling unit is housed under the water bath.

Outside dimensions: 800x430x1000 mm

Weight: 60 kg



B052-02

ACCESSORY:

EI36-10

Mercury control thermometer range 0-50 °C. div. 0,5 °C.

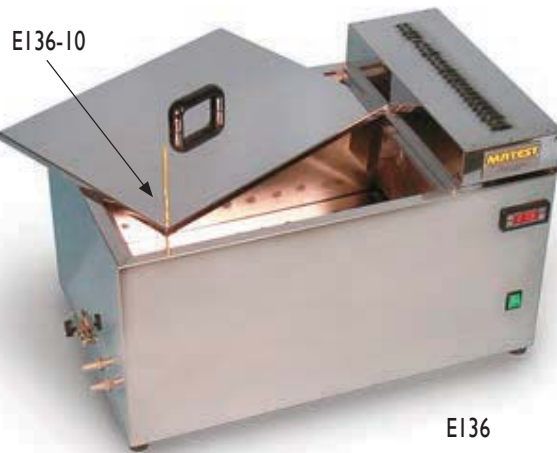

EI36-10

EI36



EI36-01

EI39

Curing cabinet

STANDARDS: EN 196-1 / ASTM C87, C109, C190, C191

Both external and internal walls are stainless steel made, and insulated by a 50 mm. thick glass wool.

The cabinet has an inner inspection glass door.

Temperature range: from ambient to 70 °C, with digital thermostat.

A dual safety/thermostat with higher thermic threshold ensures safe working conditions.

Humidity range: 90% to saturation

Power supply: 230V 1ph 50/60 Hz 1000 W

Inside dimensions: 620x440x400 mm

Overall dimensions: 900x700x800 mm

Weight: 60 kg



EI39

ACCESSORY:

VI65

THERMO-HYGROMETER for humidity and temperature control. Technical details: see pag. 482



E138

Large capacity curing cabinet

STANDARDS: EN 196-1 / EN ISO 679

ASTM C87, C109, C190, C191 / UNE 80102

For curing large quantities of mortar, cement and concrete specimens, at controlled humidity and temperature.

Aluminium and polycarbonate made, it is complete with precision digital thermostat and four robust shelves.

The humidity from 90% to saturation is maintained through water nebulizers activated by compressed air; and the temperature by an immersion heater and refrigerator unit (accessory mod. E141)

Temperature range: from ambient to +30 °C, accuracy ± 1 °C.

The cabinet requires a compressed air source. (see accessory)

Inside dimensions: 1090x470x1200 mm

Overall dimensions: 1350x570x1600 mm

Power supply 230V 1ph 50/60 Hz 2000 W

Weight: 100 kg



E138

ACCESSORIES for mod. E138:

V206-01 Air Compressor; air displacement: 250 litres/min.
Tank capacity : 100 litres
Recommended for standard use

V206-02 Air Compressor; air displacement: 400 litres/min.
Tank capacity : 200 litres
Recommended for intensive or continuous use

E138-11 Tubing and accessories to connect the E138 cabinet to the air compressor

E134-11

Pan, 240 x 300 x 70 mm, polythene made, it accepts up to six 40,1x40x160 mm prisms for curing in water.



E134-11

ACCESSORY for mod. E136, E136-01, E138:

E141

Water refrigerator

It cools the water from room temperature up to +10°C. with supply capacity of 2 litre/minute.

Stainless steel made, complete with motor pump, digital thermostat sens. 0.1°C., it is connected to water baths and tanks where a lower temperature than the room one is required.

Complete with tubing and accessories for bath connection.

Power supply: 230V 1ph 50Hz 750W

Dimensions: 550 x 500 x 880 mm

Weight: 55 kg



E141

WORKING DIAGRAM

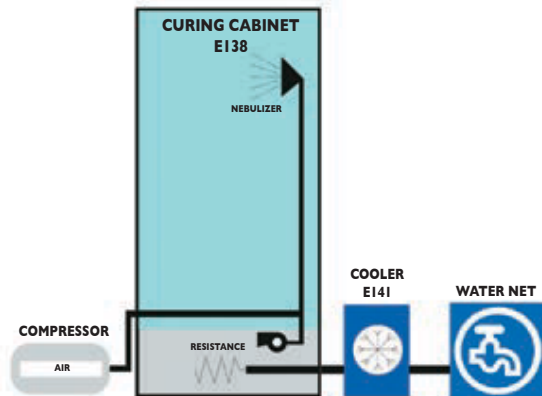

V206-01



COMPRESSION AND FLEXURAL TESTING MACHINES FOR CEMENT STRENGTH DETERMINATION

In the cement and mortar section we are in the position to supply the widest and most complete range of compression/flexural testing machines today available in the worldwide market, making Matest the leader manufacturer of strength testing machines.

The versatility and flexibility of Matest production range allows the enduser to select a cement compression/flexural frame to be combined with another frame (like for example concrete compression frame) in order to satisfy and to personalize any specific requirement.

The next pages describe:

section E

- Measuring and control systems (pag. 337 ÷ 339)
- Unitronic 50 kN and Unitronic 200 kN universal multipurpose compression/flexural and tensile frames (pag. 340)
- Two columns machines with only one measuring range for **“compression tests only”** and 250kN or 500kN capacity load (pag. 342 ÷ 345)
- Two columns machines with **“double measuring range”** with the same testing chamber, for **“compression and flexural tests”**. Ranges: 250kN or 500kN for compression tests, and 15kN for flexural tests (pag. 346 ÷ 349)
- Machines with **“double testing chamber”** and **“two independent measuring ranges”**, for **“compression”** tests in the chamber 250kN or 500kN capacity, and **“flexural”** test in the chamber 15kN capacity (pag. 350)
- Combined groups for compression and flexural tests on mortars, compression/flexural tests on concrete, splitting, block tests; suitable to personalize and satisfy any specific requirement (pag. 353)



336



MATEST

CI08N DIGITEC C098N AUTOTEC

Two-channels computerised graphic display system to control and manage all sorts of automatic (Autotec C098N) and semi-automatic (Digitec CI08N) testing machines, for acquisition, display, processing, printing and saving the test data and certificates, with software for remote control from PC.

TO UPGRADE OR COMPLETE YOUR CONCRETE OR MORTAR COMPRESSION AND FLEXURE TESTING MACHINE (also from other manufacturers).

The system can manage and process the data in compliance with EN 12390 Specification and the different International Standards, for the following tests:

- Compression on concrete
- Flexure on concrete
- Splitting on concrete cubes and cylinders
- Compression and flexure on mortar
- CI27N On board graphic printer
- RS232 connection with remote control to PC

Specifications Digitec / Autotec::

- **2 analogue-digital channels** connectable to two different compression/flexure frames.
- Simple and immediate set up of the parameters and test execution, menu driven. The use does not require specialised staff.

- Rapid approaching, touching on and breaking of the specimen under direct pump control (Autotec C098N)
- Automatic control of the pace rate (Autotec C098N)
- Continue load display.
- Breaking load detection.
- Automatic elaboration of the specific resistance value.
- Permanent file up to 1000 tests and file of 100 different types of specimens.
- Graphic display with high resolution: 192x64 pixels.
- Selectable measuring force: kN, lb
- Languages: English, French, German, Spanish, Italian, Polish, Czech, Turkish.
- **Class: 0,5%** starting from 10% of maximum value, on request from 1% of maximum value.



Technical details and accessories: see pag. 155



CI09N CYBER-PLUS CI04NSERVO-PLUS

evolution

An electronic evolution with 8 analog inputs for compression and flexural testing machines on concrete and mortar.

Designed with the latest technology, an innovative PC-like **Touch Screen** system, employed to control and manage all sorts of automatic (Servo-Plus Evolution CI04N) and semi-automatic (Cyber-Plus Evolution CI09N) testing machines.

To update or complete your compression and flexural testing machine on concrete and mortar (also on Non-Matest brands)

The system can manage and process the following tests:

section E



338

Compression and flexure on cement

CI27N On board graphic printer

Compression on concrete

Tensile on steel

Flexure on concrete

CI09N

Splitting test on concrete cubes and cylinders

CI04N

(CI04-04)

INTERNET support

Connection to the internet for remote online assistance.

CI28 USB laser printer for graphs and certificates

H009-01
PC connection.
Remote control from PC.

MATEST

Main Features:

The control unit Cyber/Servo-Plus Evolution runs like a standard PC based on Windows operating system.

The touch-screen graphical icon interface allows easy set up of the parameters and immediate execution of the test.

High resolution color display, 1/4 VGA, offers all the functions of a PC for the management and analysis of the data, test results, and graphs.

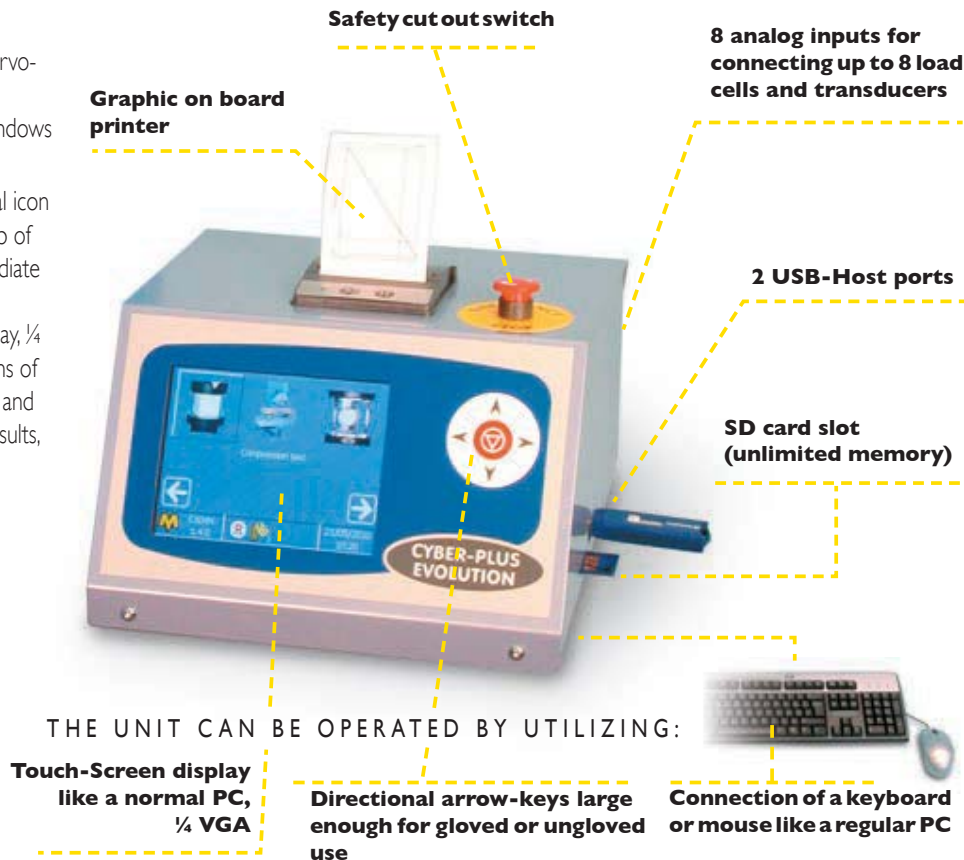

THE UNIT CAN BE OPERATED BY UTILIZING:

Touch-Screen display like a normal PC, 1/4 VGA

Directional arrow-keys large enough for gloved or ungloved use

Connection of a keyboard or mouse like a regular PC use

Direct connection of the Cyber/Servo Plus Evolution to the Intranet (direct connection to a LAN network) and Internet to establish a remote communication and receive a diagnostic analysis of a potential problem, the ability to execute the test from distance, and to provide updates of the software.

Matest technicians will check the unit located abroad to guarantee a prompt and professional assistance.

Internet direct connection for remote assistance

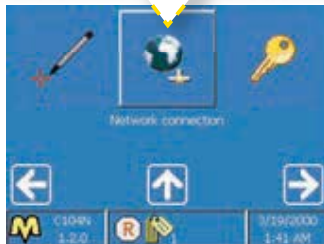

Windows operating system like a standard PC. Touch-Screen color display, 1/4 VGA



Main functions

- More intuitive interface which simplifies the use of the machine (test begins after a few simple inputs)
- Greater calculation ability and data visualization (on board charts and graphic print-outs)
- High management capacity for the multilingual framework and international settings (date and time, decimal units, unit of measure).
- Elastic software which allows the installation of new tests when desired.
- Profile configuration manager
- Configuration and calibration supervision of the analog channel
- Alarms manager
- Ethernet parameters configuration
- International settings configuration
- Hardware diagnosis functions
- Functions for the software update and licenses

- Execution of tests through parameters set up customization
- Several levels of protection (passwords) to prevent the accessibility to the configuration menus by unauthorized staff.

Cyber-Plus Evolution CI09N and Servo-Plus Evolution CI04N are supplied complete with licenses for the execution of the following tests:

- COMPRESSION on mortar
- FLEXURAL on mortar
- COMPRESSION on Concrete
- FLEXURAL on Concrete
- SPLITTING TEST on cylinders and concrete cubes

In accordance to the following standards: UNI EN, ASTM, BS, NF, UNE, DIN etc.

Technical details, features and accessories: see pag. 158



S205

UNITRONIC 50 kN, UNIVERSAL MULTIPURPOSE COMPRESSION/FLEXURAL AND TENSILE FRAME FOR:

- COMPRESSION / FLEXURAL TESTS, 50 kN MAX. CAPACITY LOAD
- TENSILE TESTS, 25 kN MAX. CAPACITY LOAD (see mod. S205-05)

WITH AUTOMATIC LOAD OR DISPLACEMENT/DEFORMATION CONTROL, for testing:

Cement / Mortar

- Concrete
- Rock and stones
- Clay blocks
- Metal, plastic, wires, ropes, textiles, papers etc.
- Asphalt
- Soil

Unitronic technical details and additional specific tests are described at pag. 414

SPECIFIC APPLICATIONS ON CEMENT AN MORTAR:

Flexural test on mortar prisms 40x40x160mm

Standards: EN 196-1 / ASTM C348 / NF P15-451 / DIN 1164
EN ISO 679

Test development with load control.

Needed accessories:

- S337-32** Strain gauge load cell 10 kN capacity.
- S212-05** Loading piston.
- E172-01** Flexure EN device for 40x40x160 mm specimens. (available also to ASTM, see pag. 352)
- E164** Software for flexural tests.



Compression test on mortar specimens

(50kN max. load)

Standards: EN 196-1 / EN ISO 679 / ASTM C109, C349
NF P18-411 / UNE 80101 / BS 3892 / DIN 1164

Test development with load control.

Needed accessories:

- S337-34** Strain gauge load cell 50 kN capacity.
- S212-05** Loading piston.
- E170** Compression device on portion of 40x40x160mm specimens. (devices for different specimens described at pag. 352)
- E163** Software for compression tests.



S205
with load
cell

Tensile test on mortar briquettes "8" shaped

Standards: ASTM C190, C307 / AASHTO T132

Needed accessories:

- S205-05** Unitronic Compression / Tensile
- S337-32** Tensile/Compression strain load cell 10kN capacity
- S205-07** Tensile jaws "8" shaped for mortar briquette
- S205-08** Software for tensile test
- E111** Briquette mould (see pag. 332)



S205-05

Unitronic Compression 50 kN/Tensile 25 kN

The Unitronic frame S205 is modified and improved to perform also tensile tests with max. capacity of 25 kN.



S206N

UNITRONIC 200kN “Matest made”

UNIVERSAL ELECTROMECHANICAL FRAME, 200KN CAPACITY, “TOUCH-SCREEN” FOR: COMPRESSION / FLEXURE / TENSILE TESTS OF CONSTRUCTION MATERIALS WITH SERVO-CONTROLLED SYSTEM OF LOAD OR DISPLACEMENT/STRAIN.

Unitronic 200kN is the universal and versatile machine fully satisfying the needs of control, research and university laboratories to carry out tests on:

Cement, Roads (Marshall, Duriez, CBR etc.), Steel, Concrete, Wood, Plastic, etc.

The load is applied by a mechanical jack activated by a “brushless closed-loop motor with optical encoder” controlled by a microprocessor.

The two crossheads foresee couplings to fix the different test devices (see accessories).

The stress is measured by an electric load cell; the measurement and the displacement control of the crosshead is achieved by the electronic device incorporated into the machine.

Stroke electric end excursion switches of the upper mobile crosshead are foreseen to save the machine from accidental handlings.

Specifications of the Firmware: see page 24

Specifications of the Frame: see page 420

The Unitronic 200kN is **supplied complete with:**

Electric load cell 200kN capacity, crosshead displacement device, upper with seat ball and lower compression platens.

“Are not included”: accessories and software for specific tests that must be ordered separately (see accessories).

Note: The machine can be equipped with intermediate load cells to the max. capacity of the machine, to satisfy specific test requirements.

Power supply: 230V 1ph 50/60Hz 850W

Dimensions: 950 x 560 x 2400 mm. Weight: 820 kg



S206N

section E



34 I

Compression test on mortar specimens

STANDARDS: EN 196-1 / ASTM C109, C349 / NF P15-451 / EN ISO 679 / DIN 1164 / BS 4550

S206N Unitronic 200 kN

E170 Compression device on portions of 40x40x160mm specimens (devices for different specimens described at page 352)

E163N Software for the compression test (page 14)



E170

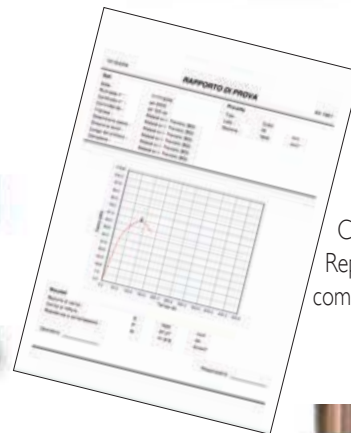

CI63N Report of the compression test

Flexural test on mortar prisms 40x40x160 mm

STANDARDS: EN 196-1 / ASTM C348 / NF P15-451 / DIN 1164 / EN ISO 679

S206N Unitronic 200 kN

E172-01 Flexure device for 40x40x160mm specimens (available also ASTM, see page 352)

S337-32 Strain gauge load cell 10 kN capacity

S206-32 Flange/connector of the load cell S337-32

S164N Software for the flexural test (page 14)



E172-01

Tensile test on mortar briquettes “8” shaped

STANDARDS: ASTM C190, C307 AASHTO T132

S206N Unitronic 200 kN

S205-07 Tensile jaws “8” shaped for mortar briquette

E111 Briquette mould (page 332)

S337-32 Strain gauge load cell Tensile/Compression 10kN capacity

S206-32 Flange/connector of the load cell S337-32

S205-08N Software for tensile tests



S337-32

S205-07

Additional specific accessories for tests on: Concrete, Asphalt, Soil, Steel, see pag. 420

MATEST

MACHINES FOR ONLY COMPRESSION TESTS

FOR CEMENT AND MORTAR SPECIMENS, BRICKS, ROCKS, REFRACTORIES etc.

STANDARDS: EN 196-1 / EN ISO 679 / ASTM C109, C349 / NF P18-411 / UNE 80101
DIN 1164 / BS 3892

Designed to perform compression tests on portions of prism 40,1x40x160 mm, cubes side 40, 50, 70, 100 mm and 2"; cores with max. height of 180 mm, by using the suitable compression devices described in next pages (accessories mod. E170 - E171-01)

- Two columns high stiffness frame.
- Max. vertical daylight between platens: 185 mm
- Platens diameter: 153 mm
- Ram travel: 45 mm approx.
- Accuracy: Grade 1 starting from 1/10 of the scale
- Gauge dia. 200 mm, range 0-300kN, subdiv. 2,5kN
- Supplied complete with lower compression platen and coupling piece to easily fix the compression device.
- Power supply (motorized models): 230V 1ph 50Hz 750W
- Weight: 300 - 330 kg



E159D + C127N + E170



E161A + C127N + E170



E151 + E170

COMPRESSION

Model	Max load kN	Manual	Motorized	LOAD MEASURING SYSTEM		
				Gauge	Digitec mod. C108N (pag. 155)	Autotec mod. C098N (pag. 155)
E151	300	•		•		
E155	300		•	•		
E159 D	500		•		•	
E159-01 D	250		•		•	
E161 A	250		•			•
E161-02 A	500		•			•



ACCESSORIES FOR COMPRESSION MACHINES:

E170

COMPRESSION DEVICE for portions of prism 40,1x40x160 mm broken in flexure. EN 196, EN/ISO 679, ASTM C349. See pag. 352

E171

COMPRESSION DEVICE for cubes 50 mm and 2" side. ASTM C109. See pag. 352

E171-01

COMPRESSION DEVICE for cubes 70,7 mm side. BS 4550. See pag. 352



E170



E171

E171-01

E161-05 DISTANCE PIECE, 50 mm high

E161-06 DISTANCE PIECE, 25 mm high

Note: the compression devices do not require any distance piece.

C127N GRAPHIC PRINTER on thermo-paper on board

C127-11 THERMO-PAPER roll for printer (pack of 10 rolls)

E161-12 SAFETY GUARDS, polycarbonate made, to CE Safety Directive, complete with hinges and lock

C121-51 STOP SWITCH on safety guards. See pag. 244

C097-05

CLASS 1, starting from 1% of the full range. With a special calibration procedure it is possible to grant Class 1 practically on the full range of the compression machine. Applicable only on digital machines.

E163

SOFTWARE for compression tests. Developed for the managing and the remote control from a PC. To be used with Digitec models. See pag. 14



E163

Software compression

C123

SOFTWARE "Servonet" for the fully automatic managing and remote control from a PC. To be used with Autotec models. See pag. 14

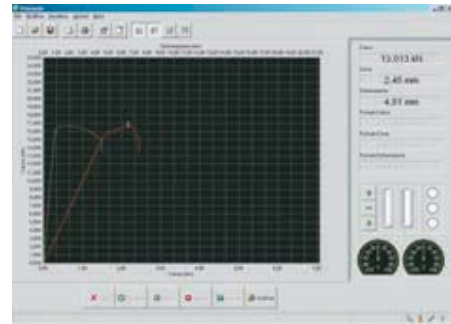

C123

Software "servonet"

H009-01

PERSONAL COMPUTER, LCD 22" monitor, keyboard, mouse, cables. The supply of the PC includes the installation of the software

E161-11 BENCH, to hold the compression frame.



E161-11

C115-01

TWO WAY HYDRAULIC VALVE, connected to the Digital machines, to activate a second frame. Technical details: see pag. 245



C115-01



C106-10

C106-10

FLEXURAL DEVICE FOR CONCRETE BEAMS 100x100x400 mm and 150x150x600 mm.



MACHINES FOR ONLY COMPRESSION TESTS

To test cement and mortar specimens, bricks, rocks, refractories etc.

Cyber-Plus or Servo-Plus Evolution Touch Screen Digital System

STANDARDS: EN 196-1 / EN ISO 679 / ASTM C109, C349 / NF P18-411 / UNE 80101
DIN 1164 / BS 3892



Designed to perform compression tests on portions of prism 40,1x40x160 mm, cubes side 40, 50, 70, 100 mm and 2"; cores with max. height of 180 mm, by using the suitable compression devices described in next pages (accessories mod. E170 - E171-01)

- Two columns high stiffness frame.
- Max. vertical daylight between platens: 185 mm
- Platens diameter: 153 mm
- Ram travel: 45 mm approx.
- Accuracy: Grade 1 starting from 1/10 of the scale
- Supplied complete with lower compression platen and coupling piece to easily fix the compression device.
- Power supply: 230V 1ph 50Hz 750W
- Weight: 300 - 330 kg

section E



E159N + C127N + E170



E161N + C127N + E170



C104-04

E161N + C127N

ACCESSORIES:

C104-04

CONSOLE HOUSING THE SERVO-PLUS EVOLUTION

The pump assembly and the digital system are encased to enhance the design and look of the machine.

C104-05

ONLINE REMOTE ASSISTANCE PACKAGE

The machine features a connection to Internet through which Matest Customer Service provides real time support to analyze the problem, to find possible solution, and to carry out a proper test execution.

COMPRESSION

Model	Max load kN	Motorized	LOAD MEASURING SYSTEM	
			Cyber-Plus Evolution mod. C109N (pag. 158)	Servo-Plus Evolution mod. C104N (pag. 158)
E159 N	500	•	•	
E159-01 N	250	•	•	
E161 N	250	•		•
E161-02 N	500	•		•



344

ACCESSORIES FOR COMPRESSION MACHINES:

E170

COMPRESSION DEVICE for portions of prism 40,1x40x160 mm broken in flexure. EN 196, EN/ISO 679, ASTM C349. See pag. 352

E171

COMPRESSION DEVICE for cubes 50 mm and 2" side. ASTM C109. See pag. 352

E171-01

COMPRESSION DEVICE for cubes 70,7 mm side. BS 4550. See pag. 352



E170



E171

E171-01

E161-05 DISTANCE PIECE, 50 mm high

E161-06 DISTANCE PIECE, 25 mm high

Note: the compression devices do not require any distance piece.

C127N GRAPHIC PRINTER on thermo-paper on board

C127-11 THERMO-PAPER roll for printer (pack of 10 rolls)

E161-12 SAFETY GUARDS, polycarbonate made, to CE Safety Directive, complete with hinges and lock

C121-51 STOP SWITCH on safety guards. See pag. 244

C097-05

CLASS 1, starting from 1% of the full range. With a special calibration procedure it is possible to grant Class 1 practically on the full range of the compression machine.

E163N

SOFTWARE for compression tests. Developed for the managing and the remote control from a PC. To be used with Cyber-Plus Evolution models. See pag. 14

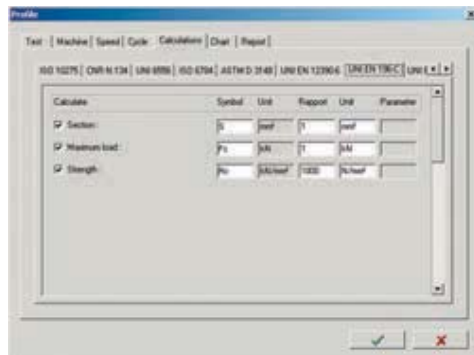

E163N

Software compression

C123N

SOFTWARE "Servonet" for the fully automatic managing and remote control from a PC. To be used with Servo-Plus Evolution models. See pag. 14

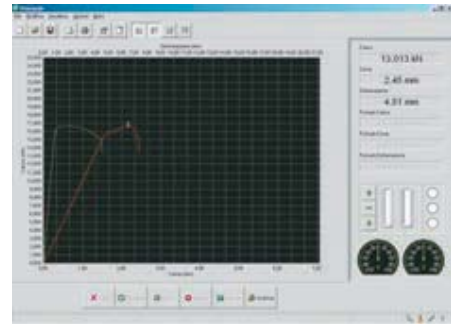

C123N

Software "servonet"

H009-01

PERSONAL COMPUTER, LCD 22" monitor, keyboard, mouse, cables. The supply of the PC includes the installation of the software

E161-11 BENCH, to hold the compression frame.



E161-11

C115-01

TWO WAY HYDRAULIC VALVE, to activate a second frame. Technical details: see pag. 245



C115-01



C106-10

C106-10

FLEXURAL DEVICE FOR CONCRETE BEAMS 100x100x400 mm and 150x150x600 mm



COMPRESSION/FLEXURAL TESTING MACHINES WITH DUAL MEASURING RANGE

FOR CEMENT AND MORTAR SPECIMENS, BRICKS, ROCKS, REFRACTORIES etc.

STANDARDS: EN 196-1 / EN ISO 679 / ASTM C109, C348, C349
 NF P18-411, P15-451 / UNE 80101 / DIN 1164
 BS 3892, 4550, 4551

These testing machines foresee a dual measuring range in the same testing chamber. The two ranges can be used alternatively and are suitable to perform:

- Flexural tests on cement prisms 40,1x40x160 mm (selecting the low capacity range)
- Compression tests on portions of prism 40,1x40x160 mm broken in flexure, cubes side 40, 50, 70, 100 mm 2", cores with max. height of 180 mm (selecting the nominal range)

by using the suitable compression devices described in next pages (accessories E170 - E172-01)

The machines with digital readout are equipped with "two suitable pressure transducers" granting the Class 1 from 1/10 on both the measuring ranges.

The measuring range 0 - 15kN can be also used for compression tests on specimens with expected low strength values.

- Two columns high stiffness frame.
- Max. vertical daylight between platens: 185 mm
- Platens diameter: 153 mm
- Ram travel: 45 mm approx.
- Accuracy: Grade 1 starting from 1/10 of the scale for both the ranges.
- Two gauges dia. 200 mm:
 range 0-300kN, subdiv. 2,5kN
 range 0 - 50kN, subdiv. 0,5kN
- Supplied complete with lower compression platen and coupling piece to easily fix the compression devices.
- Power supply (motorized models):
 230V 1ph 50Hz 750W
- Weight: 310 - 340 kg



E161-01A + C127N + E172-01



E160D + C127N + E170



E156 + E170

COMPRESSION / FLEXURAL

Model	Dual range kN	Manual	Motorized	LOAD MEASURING SYSTEM		
				Gauges	Digitec mod. C108N (pag. 155)	Autotec mod. C098N (pag. 155)
E152	300/50	•		•		
E156	300/50		•	•		
E160 D	500/15		•		•	
E160-01 D	250/15		•		•	
E161-01 A	250/15		•			•
E161-03 A	500/15		•			•



ACCESSORIES FOR FLEXURE / COMPRESSION:

E172-01

FLEXURE DEVICE for 40,1x40x160 mm mortar specimens. EN 1015-II, EN 196-I, EN/ISO 679 See pag. 352

E170

COMPRESSION DEVICE for portions of prism 40,1x 40x160 mm broken in flexure. EN 196, EN/ISO 679, ASTM C349. See pag. 352



E170



E172-01

E171

COMPRESSION DEVICE for cubes 50 mm and 2" side. ASTM C109. See pag. 352

E171-01

COMPRESSION DEVICE for cubes 70,7 mm side. BS 4550. See pag. 352



E171-01



E171

E172-02

FLEXURE DEVICE for 40x40x160 mm mortar specimens. ASTM C348. See pag. 352

E161-05 DISTANCE PIECE, 50 mm high

E161-06 DISTANCE PIECE, 25 mm high

Note: the compression devices do not require any distance piece.

C127N GRAPHIC PRINTER on thermo-paper on board

C127-II THERMO-PAPER roll for printer (pack of 10 rolls)

E161-12 SAFETY GUARDS, polycarbonate made, to CE Safety Directive, complete with hinges and lock

C121-51 STOP SWITCH on safety guards. See pag. 244

C097-05

CLASS 1, starting from 1% of the full range. With a special calibration procedure it is possible to grant Class 1 practically on the full range of the compression machine. Applicable only on digital machines.

E163

SOFTWARE for compression tests. Developed for the managing and the remote control from a PC. To be used with Digitec models. See pag. 14

E164

SOFTWARE for flexural tests. Developed for the managing and the remote control from a PC. To be used with Digitec models. See pag. 14

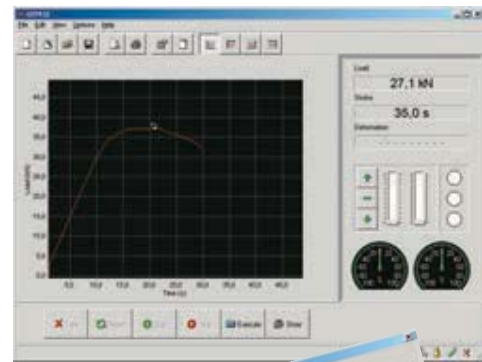

E163

Software compression

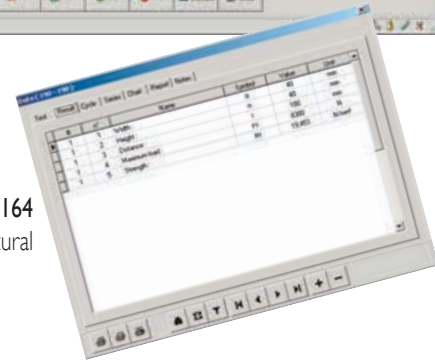

E164

Software flexural

C123

SOFTWARE "Servonet" for compression and flexural tests. Developed for the fully automatic managing and remote control from a PC. To be used with Autotec models. See pag. 14



C106-10

C106-10

FLEXURAL DEVICE FOR CONCRETE BEAMS 100x100x400 mm and 150x150x600 mm

H009-01

PERSONAL COMPUTER, LCD 22" monitor; keyboard, mouse, cables. The supply of the PC includes the installation of the software.

E161-11 BENCH, to hold the compression frame.



E161-11



COMPRESSION AND FLEXURAL TESTING MACHINES WITH DUAL MEASURING RANGE

To test cement and mortar specimens, bricks, rocks, refractories etc.

Cyber-Plus or Servo-Plus Evolution Touch Screen Digital System

STANDARDS: EN 196-1 / EN ISO 679 / ASTM C109, C348, C349 / NF P18-411, P15-451 / UNE 80101
DIN 1164 / BS 3892, 4550, 4551

These testing machines foresee a dual measuring range in the same testing chamber. The two ranges can be used alternatively and are suitable to perform:

- Flexural tests on cement prisms 40,1x40x160 mm (selecting the low capacity range)
- Compression tests on portions of prism 40,1x40x160 mm broken in flexure, cubes side 40, 50, 70, 100 mm 2", cores with max. height of 180 mm (selecting the nominal range)

by using the suitable compression devices described in next pages (accessories E170 - E172-01)

The machines with digital readout are equipped with "two suitable pressure transducers" granting the Class 1 from 1/10 on both the measuring ranges.

The measuring range 0 - 15kN can be also used for compression tests on specimens with expected low strength values.

- Two columns high stiffness frame.
- Max. vertical daylight between platens: 185 mm
- Platens diameter: 153 mm
- Ram travel: 45 mm approx.
- Accuracy: Grade 1 starting from 1/10 of the scale for both the ranges.
- Supplied complete with lower compression platen and coupling piece to easily fix the compression devices.
- Power supply: 230V 1ph 50Hz 750W
- Weight: 310 - 340 kg

E161-01N + C104-04 + C127N + E172-01



E161-01N + C127N + E172-01



E160N + C127N + E172-01

ACCESSORIES:

C104-04

CONSOLE HOUSING THE SERVO-PLUS EVOLUTION

The pump assembly and the digital system are encased to enhance the design and look of the machine.

C104-05

ONLINE REMOTE ASSISTANCE PACKAGE

The machine features a connection to Internet through which Matest Customer Service provides real time support to analyze the problem, to find possible solution, and to carry out a proper test execution.

COMPRESSION / FLEXURAL

Model	Dual range kN	Motorized	LOAD MEASURING SYSTEM	
			Cyber-Plus Evolution mod. C109N (pag. 158)	Servo-Plus Evolution mod. C104N (pag. 158)
E160 N	500/15	•	•	
E160-01 N	250/15	•	•	
E161-01 N	250/15	•		•
E161-03 N	500/15	•		•

section E



348

ACCESSORIES FOR FLEXURE / COMPRESSION:

E172-01

FLEXURE DEVICE for 40,1x40x160 mm mortar specimens. EN 1015-II, EN 196-I, EN/ISO 679 See pag. 352

E170

COMPRESSION DEVICE for portions of prism 40,1x 40x160 mm broken in flexure. EN 196, EN/ISO 679, ASTM C349. See pag. 352



E170



E172-01

E171

COMPRESSION DEVICE for cubes 50 mm and 2" side. ASTM C109. See pag. 352

E171-01

COMPRESSION DEVICE for cubes 70,7 mm side. BS 4550. See pag. 352



E171-01



E171

E172-02

FLEXURE DEVICE for 40x40x160 mm mortar specimens. ASTM C348. See pag. 352

E161-05 DISTANCE PIECE, 50 mm high

E161-06 DISTANCE PIECE, 25 mm high

Note: the compression devices do not require any distance piece.

C127N GRAPHIC PRINTER on thermo-paper on board

C127-11 THERMO-PAPER roll for printer (pack of 10 rolls)

E161-12 SAFETY GUARDS, polycarbonate made, to CE Safety Directive, complete with hinges and lock

C121-51 STOP SWITCH on safety guards. See pag. 244

C097-05

CLASS 1, starting from 1% of the full range. With a special calibration procedure it is possible to grant Class 1 practically on the full range of the compression machine.

E163N

SOFTWARE for compression tests. Developed for the managing and the remote control from a PC.

To be used with Cyber-Plus Evolution models. See pag. 14

E164N

SOFTWARE for flexural tests. Developed for the managing and the remote control from a PC.

To be used with Cyber-Plus Evolution models. See pag. 14

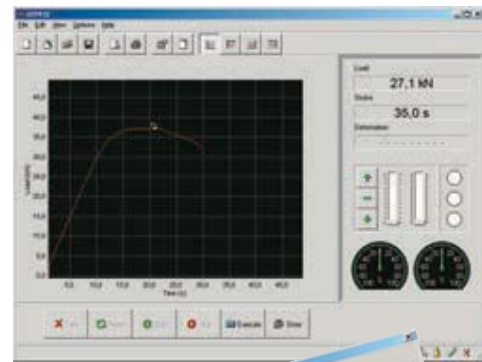

E163N

Software compression

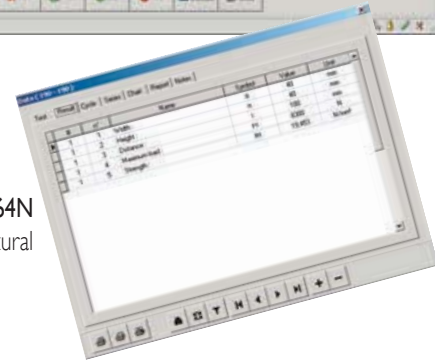

E164N

Software flexural

C123N

SOFTWARE "Servonet" for compression and flexural tests. Developed for the fully automatic managing and remote control from a PC. To be used with Servo-Plus Evolution models.

See pag. 14



C106-10

C106-10

FLEXURAL DEVICE FOR CONCRETE BEAMS 100x100x400 mm and 150x150x600 mm

H009-01

PERSONAL COMPUTER, LCD 22" monitor; keyboard, mouse, cables. The supply of the PC includes the installation of the software.

E161-11 BENCH, to hold the compression frame.

C115-01

TWO WAY HYDRAULIC VALVE, to activate a second frame. Technical details: see pag. 245



C115-01



COMPRESSION AND FLEXURAL TESTING MACHINE “HIGH PERFORMANCE” WITH DUAL TESTING CHAMBER AND TWO INDEPENDENT MEASURING RANGES 300 kN AND 15 kN WITH LOAD CELLS

Cyber-Plus or Servo-Plus Evolution Touch Screen Digital System

STANDARDS: EN 196-1 / EN ISO 679 / ASTM C109, C348, C349 / NF P18-411, P15-451 / UNE 80101
DIN 1164 / BS 3892, 4550, 4551



section E



350

This testing machine of high performance, advanced solutions and top quality components is equipped with two load chambers with two independent measuring ranges. It is suitable to perform:

- Flexural tests on cement prisms 40,1x40x160 mm (with the range 0 - 15 kN)
- Compression tests on portions of prism 40,1x40x160 mm broken in flexure, cubes side 40, 50, 70, 100 mm 2", cores with max. height of 180 mm (with the range 0 - 300 kN)

by using the suitable compression devices described in next pages (accessories E170 - E172-01)

The applied load is measured by two strain gage load cells (15kN and 300 kN) at high accuracy.

This solution eliminates the weights of the piston and lower compression platen, packing set frictions etc., granting very high accuracy (max. error within +/- 0,5%)

The load chamber 0 - 15 kN permits very accurate tests on specimens having low strength (both in compression and in flexure).

- Max. vertical daylight between platens: 189 mm
- Platens diameter: 165 mm
- Ram travel: 35 mm approx.



E181N + C127N with compression devices



E183N + C127N with compression devices

- Accuracy: Grade 1 starting from 1/10 of the scale for both the ranges.
- Safety guards to CE Directive, polycarbonate made, with hinges.
- Supplied complete with lower compression platens and coupling pieces to easily fix the compression devices (see accessories).
- Dimensions of the frame: 1300x400x1500 mm approx.
- Power supply: 230V 1ph 50Hz 750W
- Weight: 400 kg approx.

COMPRESSION / FLEXURAL

Model	Dual range kN	LOAD MEASURING SYSTEM	
		Cyber-Plus Evolution mod. C109N (pag. 158)	Servo-Plus Evolution mod. C104N (pag. 158)
E181 N	300/15	•	
E183 N	300/15		•

MATEST

ACCESSORIES FOR DUAL CHAMBER:

C104-05

ONLINE REMOTE ASSISTANCE PACKAGE

The machine features a connection to Internet through which Matest Customer Service provides real time support to analyze the problem, to find possible solution, and to carry out a proper test execution.

E172-01

FLEXURE DEVICE for 40,1x40x160 mm mortar specimens. EN 1015-II, EN 196-1, EN/ISO 679 See pag. 352



E172-01

E170

COMPRESSION DEVICE for portions of prism 40,1x 40x160 mm broken in flexure. EN 196, EN/ISO 679, ASTM C349. See pag. 352



E170

E171

COMPRESSION DEVICE for cubes 50 mm and 2" side. ASTM C109. See pag. 352



E171

E171-01

COMPRESSION DEVICE for cubes 70,7 mm side. BS 4550. See pag. 352



E171-01

E172-02

FLEXURE DEVICE for 40x40x160 mm mortar specimens. ASTM C348. See pag. 322

E161-05 DISTANCE PIECE, 50 mm high

E161-06 DISTANCE PIECE, 25 mm high

Note: the compression devices do not require any distance piece.

C127N GRAPHIC PRINTER on thermo-paper on board.

C127-II THERMO-PAPER roll for printer (pack of 10 rolls)

E183-10 SAFETY GUARDS complete with stop switch.

C097-05

CLASS 1, starting from 1% of the full range. With a special calibration procedure it is possible to grant Class 1 practically on the full range of the machine.

E163N

SOFTWARE for compression tests. Developed for the managing and the remote control from a PC. To be used with mod. E181N. See pag. 14

E164N

SOFTWARE for flexural tests. Developed for the managing and the remote control from a PC.

To be used with mod. E181N. See pag. 14

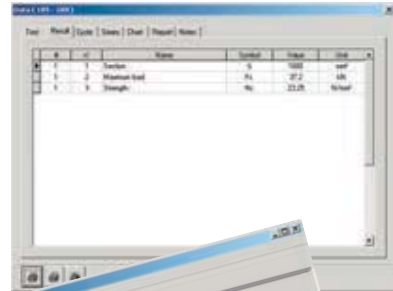

E163N
Software
compression

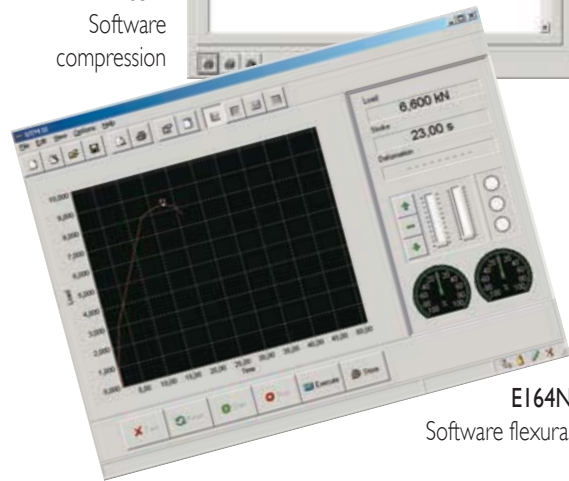

E164N
Software flexural

C123N

SOFTWARE "Servonet" for compression and flexural tests. Developed for the fully automatic managing and remote control from a PC. To be used with mod. E183N.

See pag. 14

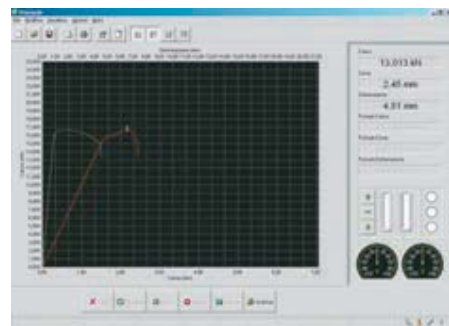

C123N
Software "servonet"

H009-01

PERSONAL COMPUTER, LCD 22" monitor; keyboard, mouse, cables. The supply of the PC includes the installation of the software.



Compression devices

To be positioned between the compression platens of the machine; they fit perfectly without removing anything and without adding any distance piece.

Dimensions: 153x153xh185 mm

MODELS:

E170

Compression device for portions of 40,1x40x160 mm prism broken in flexure

STANDARDS: EN 196-1 / ASTM C349 / NF P15-451
EN/ISO 679

The compression platens have hardness 60 HRC and upper platen is seat ball assembled. The centering plug is distant 10 mm from the compression platen, as requested by the EN 196-1 Specification. Cadmium plated for rust protection. Weight: 12 kg



E170

ACCESSORY FOR MOD. E170

E170-11

Centering plug

STANDARD: EN 1015-11

Fixed on the E170 device in replacement of the standard centering plug, it modifies the distance from the compression platen to 16 mm, as requested by EN 1015-11 Specification.

E170-01

Compression device for portions of 40,1x40x160mm prism broken in flexure

STANDARD: DIN 1164

Identical to mod. E170 but with compression platens having 40x62,5 mm size, as requested by DIN Standards. Weight: 12 kg



E170-01

E170-01GO

Compression device for portions of 20x20x100 mm prism broken in flexure STANDARD: GOST 26798.1

Identical to mod. E170 but with compression platens as requested by Russian Standard



E172-01GO

E170-01GO

E171

Compression device for cube 50 mm and 2" side

STANDARD: ASTM C109

Platens diameter: 72 mm and upper platen is seat ball assembled.

This device can be used also to test cores max. 50 mm height.

Dimensions: 153x153xh185 mm

Weight: 12 kg



E171

E171-01

Compression device

for cube 70,7 mm side STANDARD: BS 4550

It can be used also to test cores max. 70 mm height

Dimensions: 150x130xh185

Weight: 9 kg



E171-01

E172-01

Flexure device for 40,1x40x160 mm prisms

STANDARDS: EN 196-1 / EN 1015-11 / NF P15:451 / DIN 1164
EN/ISO 679

Upper bearer is seat ball assembled.

The distance between lower bearers is 100 mm and one of them has a spherical seat. Cadmium plated for rust protection.

Dimensions: 160x153xh185 mm

Weight: 11 kg



E172-01

E172-01GO

Flexure device for 20x20x100 mm prisms

STANDARD: GOST 26798.1

Identical to mod. E172-01 but with bearers as requested by Russian Standard

E172-02

Flexure device for 40x40x160 mm prisms

STANDARD: ASTM C348

Identical to mod. E172-01 but lower bearers have distance of 119 mm as requested by ASTM Standard.

Weight: 11 kg

section E



COMBINED TWO FRAMES GROUP

Upgrading option:

- COMPRESSION AND FLEXURAL TEST ON MORTAR SPECIMENS
- COMPRESSION TESTS ON CONCRETE CUBE, CYLINDER AND BLOCKS SPECIMENS, BY CHOOSING THE STANDARD COMPRESSION MACHINE AMONG OUR DIFFERENT AVAILABLE MODELS FROM 1300 kN TO 5000 kN CAPACITY (see section Concrete from pag. 168 ÷ 218)

The composition of the combined group is obtained by:

C092-05

Compression frame on mortar specimens, 250 kN or 500 kN capacity, (mod. E159D, E159-01D, E159N, E159-01N, E161A, E161-02A, E161N, E161-02N; technical details and specific accessories at pag. 312÷315) complete with pressure transducer used in conjunction with a concrete digital compression machine (Digitec, Autotec, Cyber-Plus / Servo-Plus Evolution, see pag. 168 ÷ 218).



C055 example

C092-05

C092-06

Compression/Flexural frame on mortar specimens, dual range:

0-250 kN (or 500 kN) for compression tests
 0-15 kN for flexure tests (mod. E160N, E160-01N, E161-01N, E161-03N; technical details and specific accessories at pag. 316÷319) complete with two pressure transducers used in conjunction with a concrete digital compression machine (Cyber-Plus / Servo-Plus Evolution model only, see pag. 168 ÷ 218).



C056 example

C092-06

In addition to the proposed groups, it is possible to compose many other alternative testing groups, with digital display measuring system; like for ex:

- Group formed by two concrete compression frames.



GROUP EXAMPLE

- Group formed by one concrete flexural frame and one mortar compression frame.



GROUP EXAMPLE

section E





354



E190N

Determination of MODULUS OF ELASTICITY in compression of products and systems for the protection and repair of concrete structures (Mortars) System: Automatic with pace rate control also when releasing the load

STANDARD : EN 13412

It can be used with a MATEST testing machine to be selected among the Servo-Plus Evolution models (ref. C104N, see pag. 158).

The appliance includes:

- **Hydraulic system**

It is an hydraulic installation and has a high performance valve directly controlled by the digital unit that grants the automatic control of the pace rate increasing the load, keeps a certain load and than controls the pace rate decreasing the load.

The setting of the pace rate is made by a very sensitive valve controlled by a step by step motor and it allows a micrometric action on the pace rate granting excellent results.

A laser position detector allows a rapid positioning of the piston. This grants a touching sensitivity of test starting of about 0,1 per thousand of the maximum capacity.

- **Electronic measuring system**

The high performance control and data processing unit controlled by a 32 bit microprocessor, can manage up to 8 high resolution channels for the control of load cells or transducers with strain gages bridge.



C134

The unit contains two Analogical/Digital last generation converters with 24 bits resolution. The system processes the signals coming from the load cells and from the extensometers giving all the results required for a further processing following the most updated International Standards for this application.

- **Data acquisition and processing software UTM2
License for Elastic Modulus to EN 13412.**

The software has been developed on the working line of the already known software UTM-2 (windows menu). It contains the profiles of the main Standards used, but the user can modify as he likes and personalise the test profile, that will be effected in a completely automatic way by the testing machine.

The user can introduce a list of dates concerning the specimen that will be tested and the kind of test that he wants to make: shape of the specimen, dimensions, age of the specimen, average expected breaking value, etc... The appliance allows verifying the proper reading of the extensometers and, if everything is within the expected tolerances, it manages the average deformation value read by the transducers and processed by the digital unit, than it transmits by means of the serial communication port RJ (Network Connection) to a Personal Computer; that can be already by the end user or supplied separately (not included with the Software), all the dates of the test. These dates will be processed by the software and transformed in a graph load/deformation and load/time, following the International Standards.

The software gives the possibility to print on a standard printer a test certificate reporting all the dates concerning the test and the specimen and the graph of the test. The Software includes the license "Servonet" mod. C123N while the extensometers (two models are proposed: A and B) are not included in the standard supply, and must be ordered separately (see accessories).

NOTE:

The Elastic Modulus on Mortars mod. E190N can be used together with:

- A) EXTENSOMETERS (STRAIN GAGES), SINGLE USE, ELECTRIC, available in different sizes, mod. C125-10 to C125-13 (see accessories),
- or:
- B) EXTENSOMETERS /COMPRESSOMETERS, electronic, universal, mechanical frame, mod. C134 (see accessories)

ACCESSORIES:

- A) EXTENSOMETERS (STRAIN GAGES), SINGLE USE, ELECTRIC. Pack of 10 pieces



Available models

- C125-10** Electric extensometer, base length 10 mm
- C125-11** Electric extensometer, base length 20 mm
- C125-12** Electric extensometer, base length 30 mm
- C125-13** Electric extensometer, base length 60 mm
- C125-14** Electric extensometer, base length 120 mm

- C125-15** KIT for the application of single use extensometers composed by: glue, welder; solder; cleaning liquid, accessories, the whole in carrying case

C125-09

INTERFACE MODULE, "needed accessory" to connect up to 4 electric single use extensometers. This module allows also the automatic calibration of the zero and of the measuring range after a special thermal compensation. This grants a five times better accuracy than the one requested by the Standards.



AS ALTERNATIVE:

- B) **C134** EXTENSOMETER / COMPRESSOMETER, ELECTRONIC, UNIVERSAL, MECHANICAL FRAME. It can be used only with samples having minimum height of 130 mm. Technical details: see pag. 222

C134-10

TEMPLATE, to regulate and calibrate the base length of the C134 extensometer

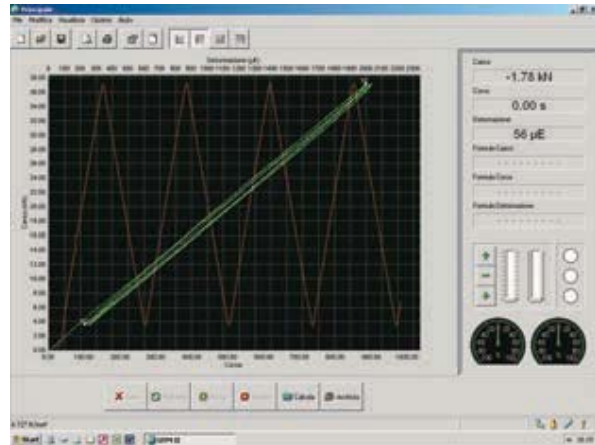

Screen during a test and marker indicating any change.

Personalisation of the test certificate.

Personalisation and composition of a test profile.

