

Section C CONCRETE

section C



The accurate and satisfactory test of fresh and hardened concrete are essential elements for any type of building realization. The final quality of the concrete utilized in the structure depends from many variables like: workability, consistency, setting, time, volumic mass, air content, compressive strength, temperature, linear variations, etc.

Matest proposes a complete range of testing and research equipment on concrete to satisfy practically all the above quality variables, in compliance with the EN, ASTM and the most known International Standards. In the second part of this section a complete range of instruments is available for non-destructive tests, to investigate and evaluate the progressive ageing and durability of concrete structures submitted to the chemical attacks, air pollution, time.



COMPRESSION AND FLEXURAL TESTING MACHINES

In the Concrete section we are in the position to supply the widest and most complete range of compression and flexural testing machines today available in the worldwide market, making Matest the leader manufacturer of testing machines. The versatility and flexibility of Matest testing machines production range allow the enduser to select and combine compression/flexural groups in order to satisfy and to personalize any specific requirement.

The next pages describe:

- 1) General features of the compression frames with different control and measuring systems (pag. 153, 154)
- 2) Compression testing machines, four columns prestressed frame, conforming to Standards: ASTM C39 / BS 1610 / UNI 6686 part 1,2 / AASHTOT22 NF P18-411 / UNE 83304 (pag. 167 ÷ 197)
- 3) Compression testing machines, four columns "tested for high stability frame", conforming to Standards: EN 12390-4 / and BS 1881 / DIN 51220 / UNI 6686 part 3, and the determination of the automatic secant compression "elastic modulus" on concrete with pace rate control also when releasing the load, conforming to Standards: ASTM C469, ISO 6784, UNI 6556, DIN 1048 (pag. 199 ÷ 221)
- 4) Flexural testing machines, conforming to Standards: EN 12390-5 EN 1340:4 / ASTM C78, C293 / UNI 6133 / BS 1881:118 NF P18-407 UNE 83305 / AASHTO T97 (pag. 224 ÷ 236)
- 5) Combined Groups for Compression, Flexural, Splitting, Block tests; cement compression/flexural frames, suitable to personalize and satisfy any specific requirement (pag. 238, 239)



COMPRESSION TESTING MACHINES

IT IS TECHNICALLY WELLKNOWN THAT THE WELDED FRAMES MAY HAVE STRUCTURAL UNEXPECTED VALUES AND PROBLEMS, WHILE THE FOUR COLUMNS CONFIGURATION GUARANTEES TENSIONAL UNIFORMITY AT ALL LOAD LEVELS.

MATEST MANUFACTURES “COMPRESSION MACHINES FOUR COLUMNS FRAME ONLY”, AND SUPPLIES TWO BASIC FRAME DESIGNS:

- MACHINES WITH FOUR COLUMNS PRESTRESSED FRAME
STANDARDS: ASTM C39 / BS 1610 / NF P18-411
UNE 83304 / AASHTO T22 / UNI 6686 part 1, 2
Models described at pag. 167 ÷ 197
- MACHINES WITH FOUR COLUMNS
“TESTED FOR HIGH STABILITY FRAME”
STANDARDS: EN 12390-4 / BS 1881 / DIN 51220
UNI 6686 part 3
Models described at pag. 199 ÷ 221



GENERAL DESCRIPTION

The load frame is extremely strong and oversized to grant high rigidity and stability.

The upper head holds the precision lapped ball-seating and the compression platen.

Compression platens are surface hardened over 55 HRC and ground.

Design emphasis has been placed on simplicity both of construction and operation so that our machines are rugged, easy to use and maintain, and designed for heavy continue use.

They are designed to conform to International Specifications as: EN, ASTM, AASHTO, BS, NF, DIN, UNI, UNE.

They are available in 1300 kN, 1500 kN, 2000 kN, 3000 kN, 4000 kN, 5000 kN capacity, both hand-operated and motorized, at one or two gauges, with electronic digital display measuring system, and with automatic servocontrolled console with microprocessor.

The different versions give the possibility to test cubes, cylinders, blocks. All the machines can be equipped with safety guards.

Hydraulic system

Piston has large diameter: this allows the hydraulic circuit to work at low pressure with longer life of the working components and higher precision in the results.

Piston is ground and lapped, and a high quality packing set of three elements is utilized.

Motorized models foresee a dial device to visualize, pre-select and control the flow allowing a uniform load rate as requested by the Standards.

A fast approach ram action device is foreseen to avoid dead times during the stroke of the ram.

Power pump is multipiston, assuring continuity of delivery.

A movement indicator visualizes instant by instant the piston's excursion during the compression test.

A hopper covering the piston is conceived to avoid the powder of the broken specimen to enter into the cylinder of the press damaging the packing set.



LOAD MEASUREMENT SYSTEMS

A) GAUGES

The gauges are Bourdon tube type. They are foreseen of max. load pointer, zero adjustment and mirror face to avoid parallax errors.

Low pressure gauge is fully protected from overload by a pressure control device.

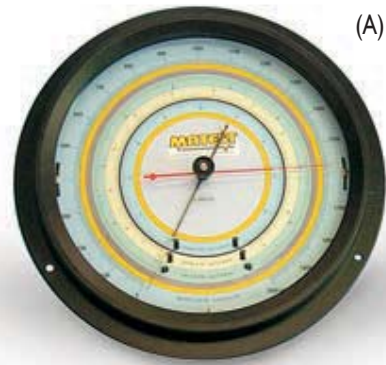

- BB) DIGITEC, TWO analog channels system, for the acquisition, visualisation and processing of the test data with software (accessory) and printout of results and certificate. Technical details: see mod: C108N, pag. 155

BB) C108N



- CC) AUTOTEC, automatic servocontrolled system, to provide fully automatic tests throughout all phases, with the support of the Digitec electronic technology. Technical details: see mod. C098N, pag. 155

CC) C098N



C) C104N
+ C104-04



- B) CYBER-PLUS Evolution, EIGHT analog channels system, for the acquisition, visualisation and processing of the test data, with software and printout of results and certificate. Resolution up to 500.000 divisions. TOUCH-SCREEN COLOUR display, same to PC. Technical details: see mod. C109N, pag. 158

B) C109N



- C) SERVO-PLUS Evolution, automatic servocontrolled system, to provide fully automatic tests throughout all phases, with the support of the Cyber-Plus Evolution electronic technology. Technical details: see mod: C104N, pag. 158



Calibration and precision

All the testing machines are calibrated with high accuracy electronic instruments and they are guaranteed in CLASS "1" (max. error \leq than $\pm 1\%$). Also starting from 1% of the full range. A Calibration Certificate is supplied along with the machine.

CI08N DIGITEC C098N AUTOTEC

Two-channels computerised graphic display system to control and manage all sorts of automatic (Autotec C098N) and semi-automatic (Digitec CI08N) testing machines, for acquisition, display, processing, printing and saving the test data and certificates, with software for remote control from PC.

TO UPGRADE OR COMPLETE YOUR CONCRETE OR MORTAR COMPRESSION AND FLEXURE TESTING MACHINE (also from other manufacturers).

The system can manage and process the data in compliance with EN 12390 Specification and the different International Standards, for the following tests:

- Compression on concrete
- Flexure on concrete
- Splitting on concrete cubes and cylinders
- Compression and flexure on mortar
- CI27N On board graphic printer
- RS232 connection with remote control to PC

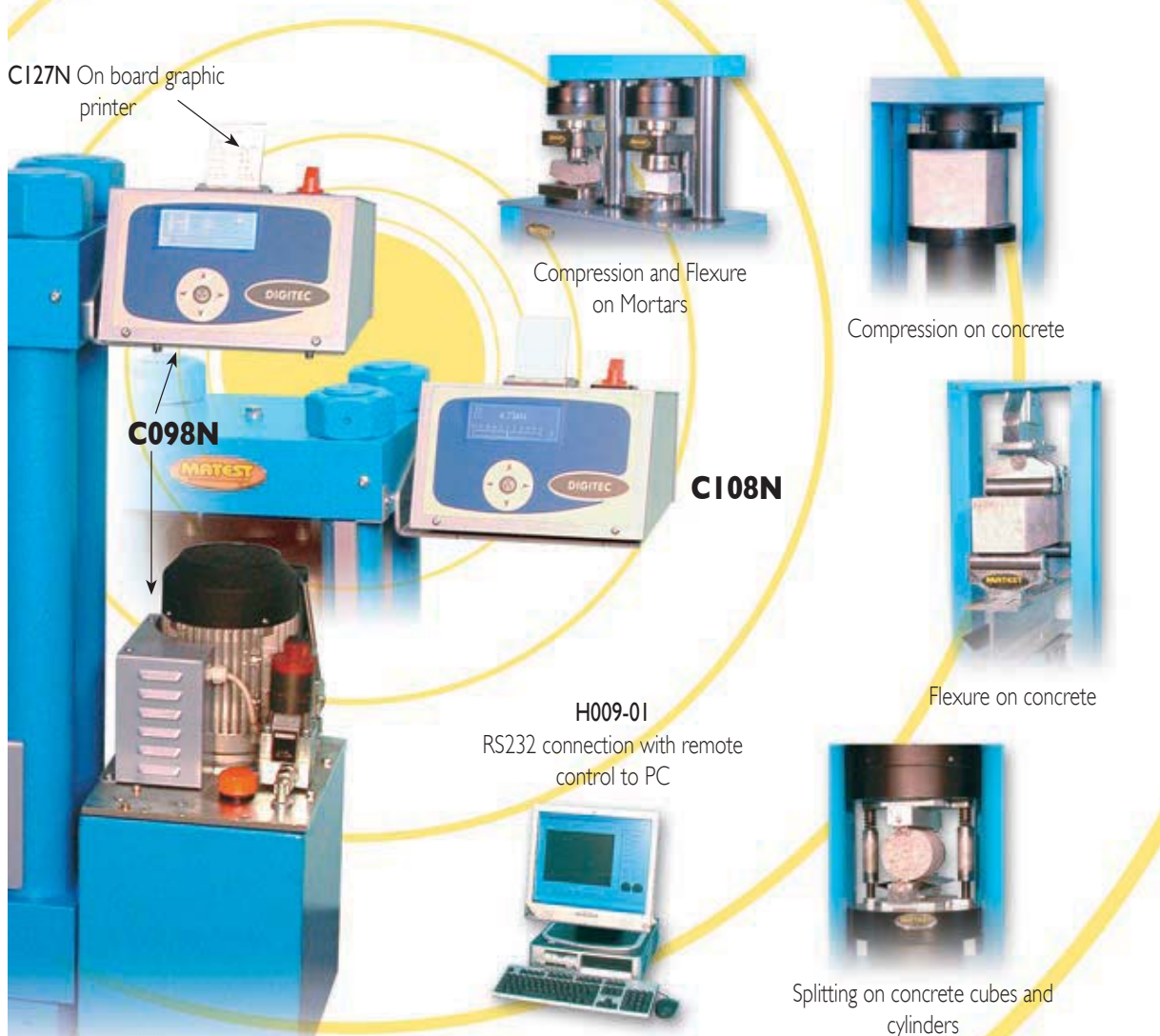

Specifications Digitec / Autotec:

- 2 analogue-digital channels connectable to two different compression/flexure frames.
- Simple and immediate set up of the parameters and test execution, menu driven. The use does not require specialised staff.
- Rapid approaching, touching on and breaking of the specimen under direct pump control (Autotec C098N)
- Automatic control of the pace rate (Autotec C098N)
- Continue load display.
- Breaking load detection.
- Automatic elaboration of the specific resistance value.
- Permanent file up to 1000 tests and file of 100 different types of specimens.
- Graphic display with high resolution: 192x64 pixels.
- Selectable measuring force: kN, lb
- Languages: English, French, German, Spanish, Italian, Polish, Czech, Turkish.
- **Class: 0,5%** starting from 10% of maximum value, on request from 1% of maximum value.



Test setup



Test execution with pace rate controller

section C



156

Technical structure

- Acquisition and data processing system at 24 bit, effective resolution: 17 bit
- Operator interface composed by 5 multi-functions pushbuttons; function icons shown on the display.
- The two analogue-digital channels accept sensors, transducers or load cells at 2mV/V
- Automatic linearity guided algorithm with very high granted accuracy (Class 0,5)
- Different programmable safety devices for the machine or the specimen as the possibility to introduce a percentage of the maximum value reached during the text execution, thermal protection of the motor and different other settable alarms.
- The firmware contains a memory of the most used specimens: area, weight, specific weight.
- Possibility of personalisation for special sized samples.
- RS232 interface: it allows transferring the data during the test or the test results directly to PC (via Microsoft Hyperterminal) or the remote control of the system by the UTM2 software (accessory)

Menu

The display shows date and time, currently applied load and single load, latest effected tests, pace rate control, rapid commands functions, configuration in use, analogue channel and activated alarm.



Max load alarm setting



Channel configuration/calibration



Functions icons (test selection, file, alarms visualisation)

MODELS:

C108N

Digitec

2 Channels unit for data acquisition and elaboration, as described.
Power supply: 230V 1ph 50/60Hz
Dimensions: 230x145x240mm
Weight: 4 kg

C127N



ACCESSORIES:

C127N On board graphic printer on thermo-paper

C127-II Spare roll of thermo-paper for printer

Software

For the remote execution of the test and the automatic transfers and filing of the results on a computer

C098N

Autotec

2 Channels servo controlled system for a fully automatic execution of the test.



The system comprises:

- Digitec C108N data acquisition unit
- Multi-piston electric pump with variable flow (see mod. C114) driven by a microprocessor (reliable and noiseless system, also for intensive and extended use)

Power supply: 230V 1ph 50Hz
Dimensions: 420x290x950mm
Weight: 60 kg

C109-10 Software for COMPRESSION test on Concrete

C109-11 Software for FLEXURAL test on Concrete

C109-12 Software for SPLITTING TEST on Concrete specimens

E163 Software for COMPRESSION test on Mortars

E164 Software for FLEXURAL test on Mortars

C123 Software "Servonet" for all the tests listed above. Suitable to be used only with the Autotec system.

H009-01

PERSONAL COMPUTER

Complete with LCD, monitor 22", keyboard, mouse, connection cables. The supply of the PC includes the installation of the purchased software.



H009-01

C098-01N

Autotec for "two frames"

2 Channels servo controlled system, complete with three way hydraulic valve for the option to connect and use up to two testing frames.



C098-01N

PRESSURE TRANSDUCER

Used with both Digitec and Autotec, supplied along with proper connection cable and relative calibration certificate.
Available Models: see pg. 246



C116N



CI09N CYBER-PLUS CI04NSERVO-PLUS

evolution

section C

An electronic evolution with 8 analog inputs for compression and flexural testing machines on concrete and mortar.

Designed with the latest technology, an innovative PC-like **Touch Screen** system, employed to control and manage all sorts of automatic (Servo-Plus Evolution CI04N) and semi-automatic (Cyber-Plus Evolution CI09N) testing machines.

To update or complete your compression and flexural testing machine on concrete and mortar (also on Non-Matest brands)

The system can manage and process the following tests:



158

CI27N On board graphic printer

Compression and flexure on cement

Compression on concrete

Tensile on steel

Flexure on concrete

Splitting test on concrete cubes and cylinders

CI09N

CI04N

(CI04-04)

INTERNET support

Connection to the internet for remote online assistance.

CI28 USB laser printer for graphs and certificates

H009-01 PC connection. Remote control from PC.

MATEST

Main Features:

The control unit Cyber/Servo-Plus Evolution runs like a standard PC based on Windows operating system.

The touch-screen graphical icon interface allows easy set up of the parameters and immediate execution of the test.

High resolution color display, 1/4 VGA, offers all the functions of a PC for the management and analysis of the data, test results, and graphs.

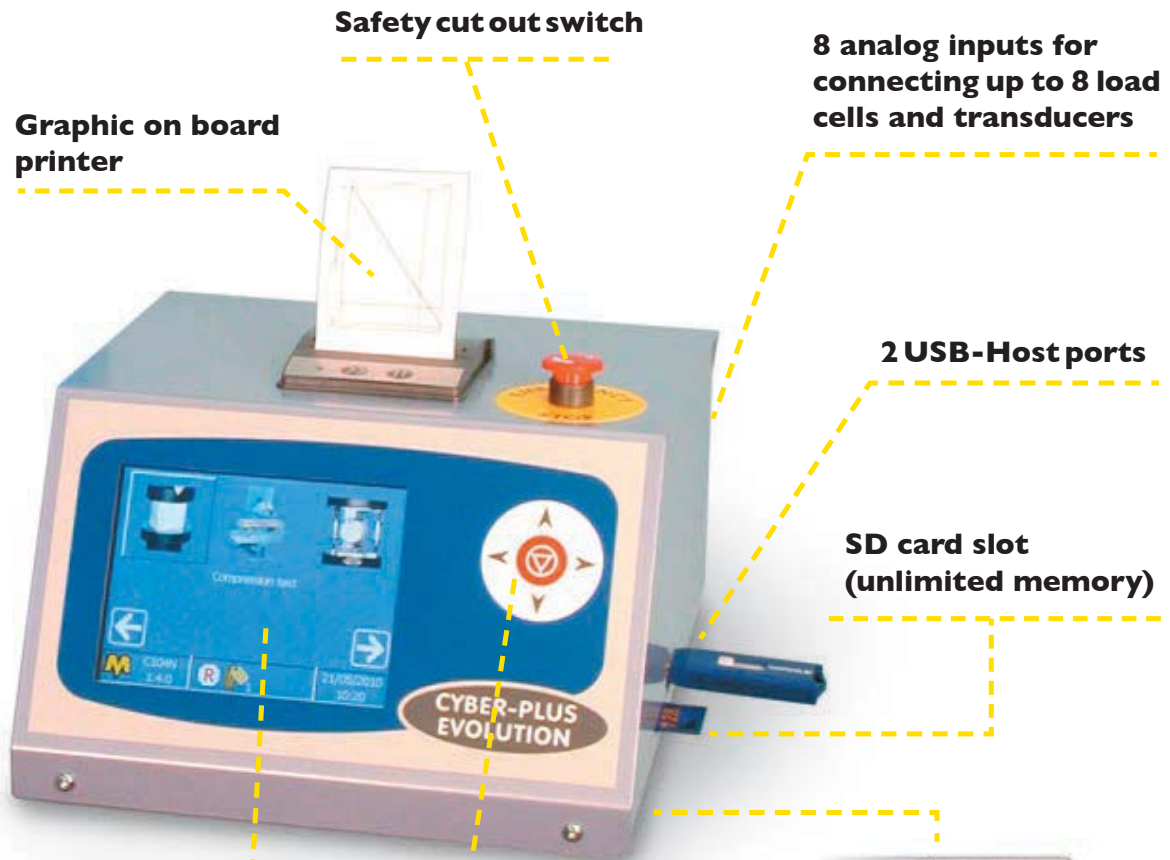

section C



THE UNIT CAN BE OPERATED BY UTILIZING:

Touch-Screen display like a normal PC, 1/4 VGA

Directional arrow-keys large enough for gloved or ungloved use

Connection of a keyboard or mouse like a regular PC

Direct connection of the Cyber/Servo Plus Evolution to the Intranet (direct connection to a LAN network) and Internet to establish a remote communication and receive a diagnostic analysis of a potential problem, the ability to execute the test from distance, and to provide updates of the software.

Mateest technicians will check the unit located abroad to guarantee a prompt and professional assistance.

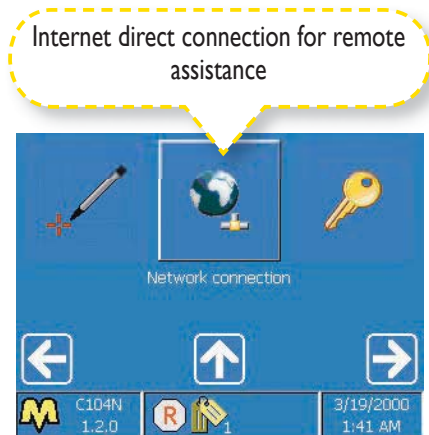

Internet direct connection for remote assistance

Windows operating system like a standard PC. Touch-Screen color display, 1/4 VGA

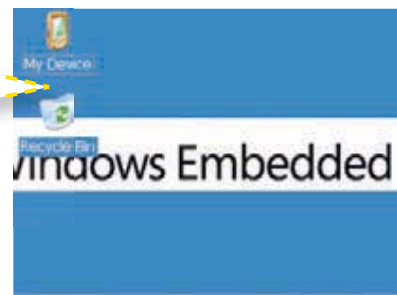

... follows...

MATEEST

section C



Qwerty Touch-Screen virtual alpha-numerical keyboard, user-friendly



International settings and unlimited language selection



Traditional directional key pad with 5 arrow-keys for standard use or when wearing gloves



160

Compression Test. Visualization of the load/time graph in real time

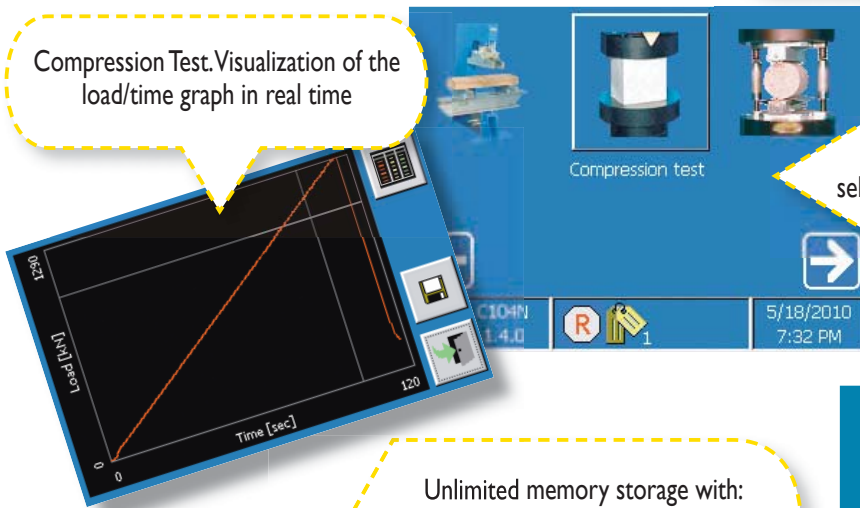

Easy and straightforward selection of the tests (compression)

Selection examples, Elastic Modulus

Unlimited memory storage with: 2 USB-Host ports* for PC, 1 SD card slot* (*memory hardware not included)



Automatic pace rate up to failure to avoid specimen's crumbling according to ASTM C39 Specification.

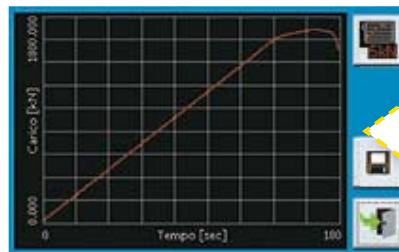

On board graphic printer

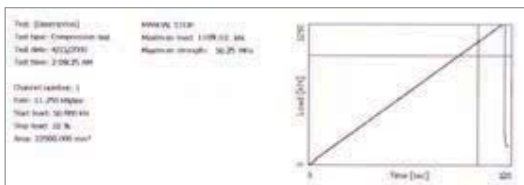

Laser printer for graphs and certificates with direct connection via USB.



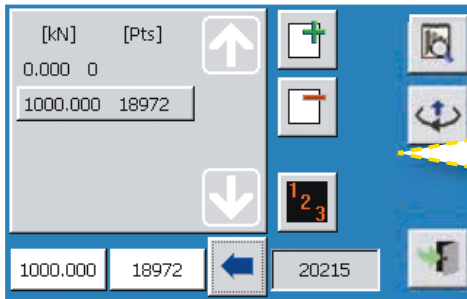

Calibration menu of a load channel. Easy set up of the calibration channel

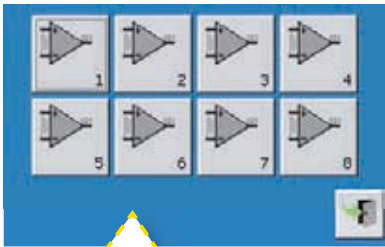

Simple and user-friendly functional channel configuration. 8 analog inputs for connecting up to 8 load cells or transducers

Endless number of test combinations and profile calibrations

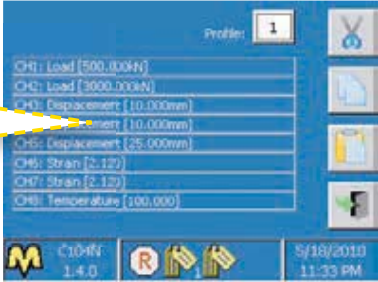

Configuration menu of a load channel. Rapid channel configuration

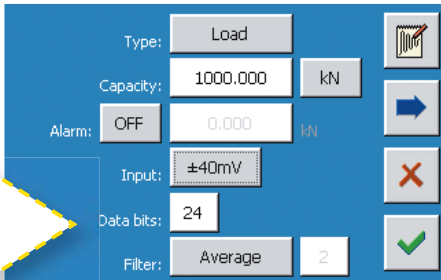

Direct LAN connection to the internet. Ethernet connection 100Mbit, for connecting the unit to the network



RS232 for PC connection only upon customer request

High technology and high performance hardware

(312 MHz Processor upgradable to 806 MHz 32Bit)

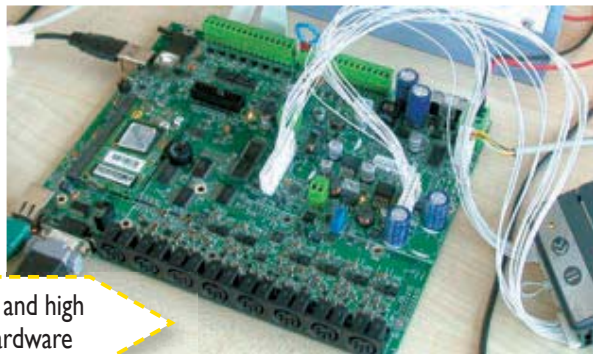

Main functions

- More intuitive interface which simplifies the use of the machine (test begins after a few simple inputs)
- Greater calculation ability and data visualization (on board charts and graphic print-outs)
- High management capacity for the multilingual framework and international settings (date and time, decimal units, unit of measure).
- Elastic software which allows the installation of new tests when desired.
- Profile configuration manager
- Configuration and calibration supervision of the analog channel
- Alarms manager
- Ethernet parameters configuration
- International settings configuration
- Hardware diagnosis functions
- Functions for the software update and licenses

- Execution of tests through parameters set up customization
- Several levels of protection (passwords) to prevent the accessibility to the configuration menus by unauthorized staff.

Cyber-Plus Evolution CI09N and **Servo-Plus Evolution CI04N** are supplied complete with licenses for the execution of the following tests:

- COMPRESSION on Concrete
- FLEXURAL on Concrete
- SPLITTING TEST on cylinders and concrete cubes
- COMPRESSION on mortar
- FLEXURAL on mortar

In accordance to the following standards: UNI EN, ASTM, BS, NF, UNE, DIN etc.

... follows...



MODELS:

C109N

Cyber-Plus Evolution

8 channel unit for data acquisition and elaboration.

Power Supply: 230V 1F 50/60Hz 70W

Dimensions: 245x55x260mm

Weight: 5kg

C104N

Servo-Plus Evolution

8 channel servo controlled unit for a fully automatic execution of the test. The machine comprises:

- Cyber-Plus Evolution C109N data acquisition system
- Multi-piston electric pump with variable flow (see mod. C114) driven by a microprocessor (reliable and noiseless system, also for intensive and extended use)

Power supply: 230V 1ph 50Hz 750W

Dimensions: 420x290x1120mm

Weight: 60 kg

section C



162



C104-01N
Servo-Plus Evolution for "two frames"
 Servo controlled unit supplied with three way hydraulic valve for the option to connect and use up to TWO TESTING FRAMES

C104-02N
Servo-Plus Evolution for "three frames"
 Servo-controlled unit supplied with four way hydraulic valve for the option to connect and use up to THREE TESTING FRAMES



ACCESSORIES:

C104-04

CONSOLE HOUSING THE SERVO-PLUS EVOLUTION

The pump assembly and the digital system are encased to enhance the design and look of the machine.

C104-09

Configuration of advanced parameters through tests on real samples

Valid for all MATEST testing machines equipped with SERVOPPLUS/CYBERPLUS controlling unit. When ordered, the setting of the advanced parameters becomes a phase of the production process. Through tests on real samples, it's possible to define in details the behavior of the tested material and therefore set into the SERVOPPLUS/CYBERPLUS controlling units advanced parameters accordingly. For the setting of the advanced parameters, it's necessary to have some real samples available at MATEST's premises.



MATEST

ACCESSORIES:

C127N On board graphic printer on thermo-paper

C127-II Spare roll of thermo-paper for printer

Software

For the remote execution of the test for the automatic transfers and filing of the results on a computer

C109-10N Software for COMPRESSION test on Concrete

C109-11N Software for FLEXURAL test on Concrete

C109-12N Software for SPLITTING TEST on Concrete specimens

E163N Software for COMPRESSION test on Mortars

E164N Software for FLEXURAL test on Mortars

C123N Software "Servonet" for all the tests listed above. Suitable to be used only with the Servo-Plus Evolution system.



C104-05

ONLINE REMOTE ASSISTANCE PACKAGE

The machine features a connection to the Internet through which the Matest Customer Service team can provide real time support to analyze any potential problem, find a possible solution, and carry out a proper execution of the test.

H009-01

PERSONAL COMPUTER

Complete with LCD, monitor 22", keyboard, mouse, connection cables. The supply of the PC includes the installation of the purchased software.

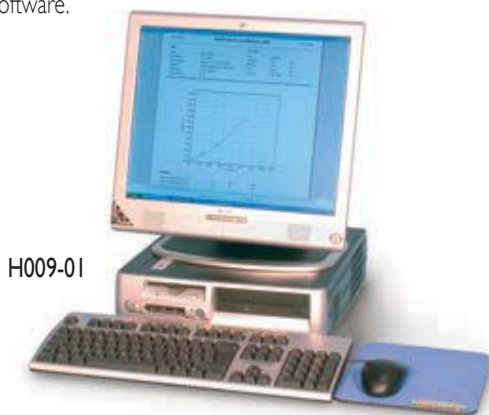

H009-01

C128

Desk laser printer for graphs and certificates with direct USB connection.



C128

PRESSURE TRANSDUCER

Used with both Cyber-Plus and Servo-Plus, supplied along with proper connection cable and relative calibration certificate.

Available Models: see pg. 246



C116N



SERVO-STRAIN

SOFTWARE-FIRMWARE for the automatic servocontrolled management of the testing machine to measure:

- LOAD OR STRENGTH
- DISPLACEMENT
- STRAIN

The “servo-strain” software/firmware can be applied “ONLY” to Matest “servo-plus evolution” testing machines.

The system is connected to displacement or strain transducers allowing to automatically perform the following tests:

- Deflection on fiber reinforced concrete beams (ASTM C1018 / EN 11039-03, 14487-1, 14488-1, 14651-05)
- Punching of sprayed concrete plate with measurement of the absorbed energy (EN 10834, 14488-3, 14488-05)
- Deformation and ductility on building materials.
- Lightweight Aggregates for concrete, mortar and grout (EN 13055-1 method 1) by using the suitable device mod.A081-01 described at pag.44
- Research tests

The applied load is automatically controlled by the “servo-plus evolution” machine.

The displacement of the piston or the strain/deformation of the sample are controlled by the “servo-strain” software, through a linear strain gage transducer (accessory), calculating values such as deflection, energy absorption, ductility.

Technical features:

See “servo-plus evolution” mod.C104N (pag. 158), and in addition:

- Real time Graphical/Numerical visualization of all the test data (load, strain, displacement, energy absorption, deflection, ductility etc.)
- Printing of test results and certificate on the onboard printer, or on a laser printer (accessories) directly connected to the machine via USB port.
- Personalized management of the archive exportable through pendrive.
- Possibility to connect up to 3 test frames
- Eight analog channels to connect load cells or pressure transducers with strain gage technology, linear displacement/deformation transducers and with strain gage technology.

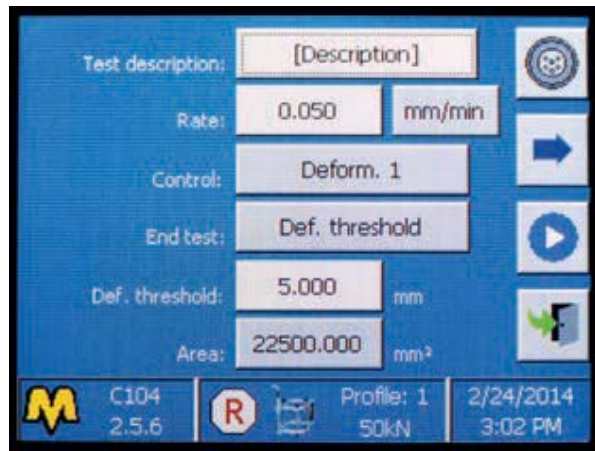

C104-10N Set up of customized compression test

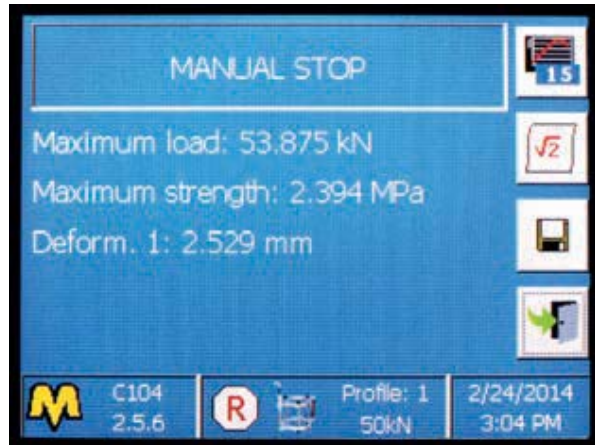

C104-10N Exemple of test result

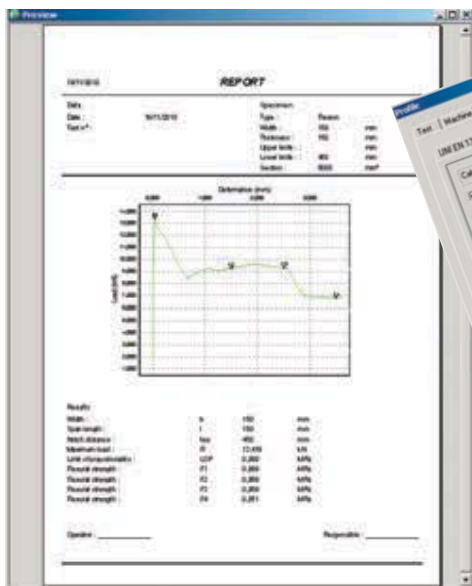

C104-10N Test report

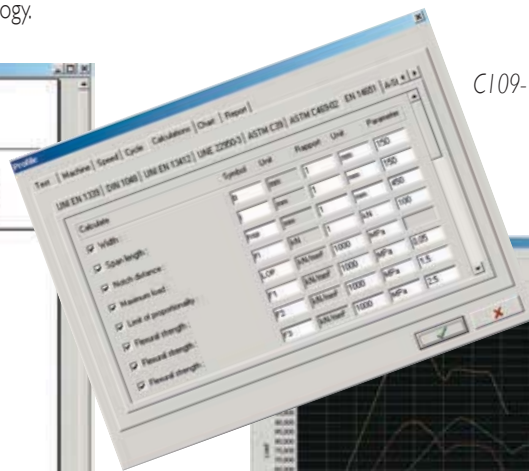

C109-15N Calculation set up

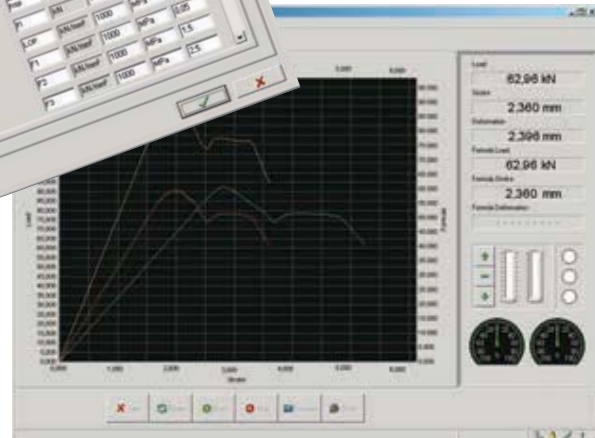

C104-10N Test graph



SERVO-STRAIN AVAILABLE APPLICATIONS:

C104-10N

Strain, Ductility, Post-breaking behaviour

Lightweight aggregates for concrete (EN 13055-1)

Compression tests on concrete specimens, fiber reinforced concrete (FRC), concrete reinforced with polymer fiber lining (FRP), building materials, and for research and experimental tests in order to evaluate the behavior of a specimen subjected to compression stress.

With High stability “Servo-Plus Evolution” compression machines:

C104-31SP

SUPPORTING DEVICE for displacement transducer, able to grant an high precision and an high stability control of the test in mm/min.

NEEDED ACCESSORIES:

S336-11

LINEAR DISPLACEMENT TRANSDUCER, strain gage technology, 10 mm travel, to permit a control between 0,03 mm/min and 2 mm/min

AS ALTERNATIVE:

S336-14

LINEAR DISPLACEMENT TRANSDUCER, strain gage technology, 50 mm travel to permit a control between 0,2 mm/min and 2 mm/min

Other models of linear displacement transducers at page 453

With all the other “Servo-Plus Evolution” machines:

C104-31 HOLDER for displacement transducer.

NEEDED ACCESSORY:

S336-14

LINEAR DISPLACEMENT TRANSDUCER, strain gage technology, 50 mm travel.

Other models of linear displacement transducers listed at page 453



section C



165



S336-14
C104-31SP



C089-10N + C104-10N
S336-14 + C104-31

C109-15N

Deflection measurement on fiber reinforced concrete beams 100x100x400(500) mm and 150x150x500(600) mm. Standards: EN 11039-03, 14487-1, 14488-1, 14651-05 / ASTM C1018

It is used with a flexural frame machine with Servo-Plus Evolution (to be selected among the models C090-07N, C091-03N) with the addition of the specific equipment required to perform the test, that is described and illustrated in detail at pag. 232

Punching test on sprayed concrete specimens with measurements of the energy absorption. Standards: EN 10834, 14488-3, 14488-05

It is used with the flexural frame machine with Servotronic model C090-07N, with the addition of the specific equipment required to perform the test, that is described and illustrated in detail at pag. 233



C090-15 + C109-15N
fixed on the flexural machine C090-07N



C109-15N
Test result



C109-15N
Set up of deflection

C090-14 + S336-14 + C109-15N
fixed on the flexural machine C090-07N

MATEST

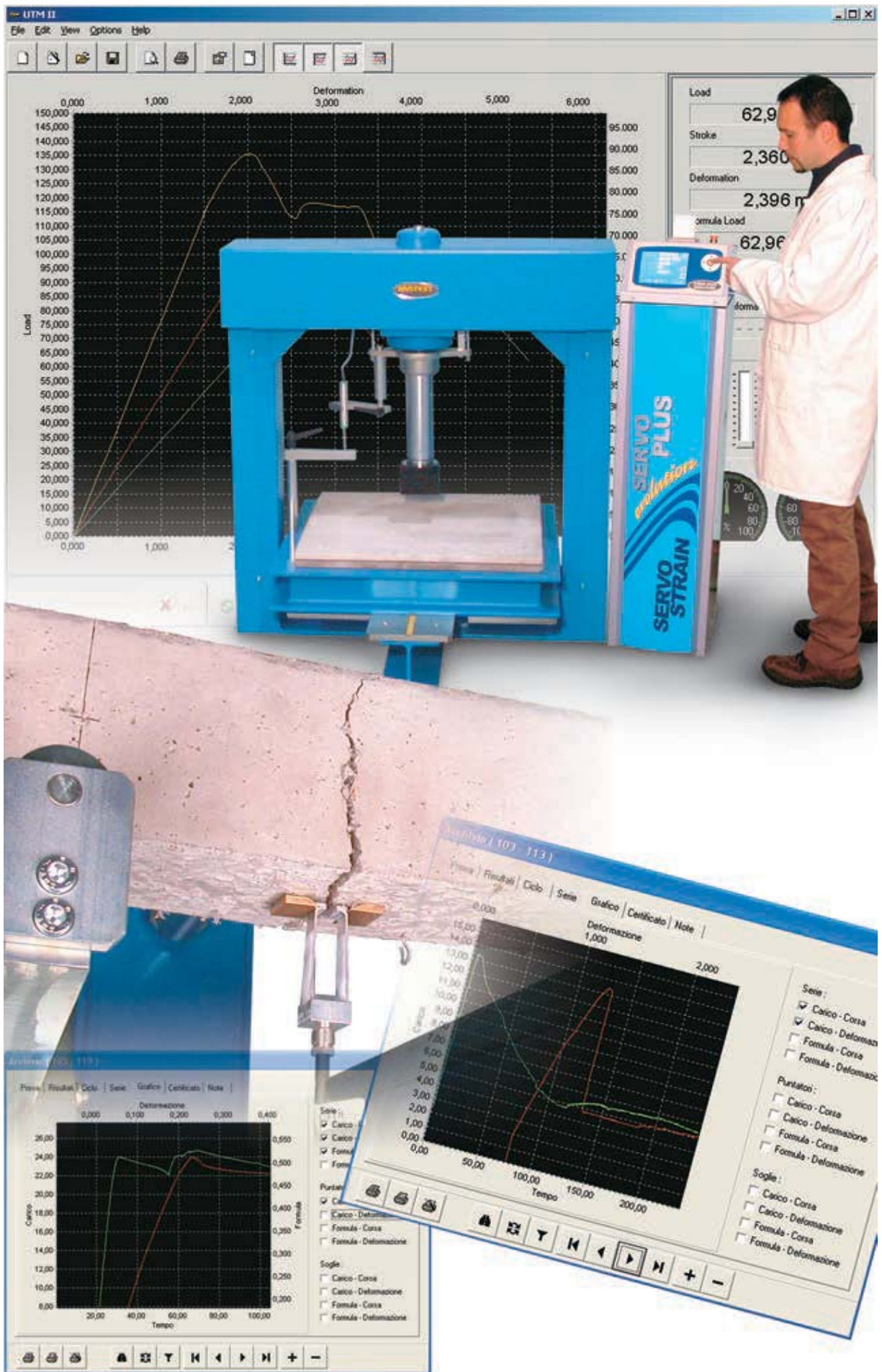

UTM II

File Edit View Options Help

Deformation 0,000 1,000 2,000 3,000 4,000 5,000 6,000

Load 0,000 15,000 30,000 45,000 60,000 75,000 90,000 105,000 120,000 135,000 145,000 150,000

Load 62,9

Stroke 2,360

Deformation 2,396

Formula Load 62,96

SERVO PLUS evolution

SERVO STRAIN

Archivio (103 - 113)

Carico 0,00 2,00 4,00 6,00 8,00 10,00 12,00 14,00 16,00

Deformazione 0,000 1,000 2,000

Tempo 50,00 100,00 150,00 200,00

Archivio (95 - 119)

Carico 0,00 10,00 20,00 30,00 40,00 50,00 60,00 70,00 80,00 90,00 100,00

Tempo 20,00 40,00 60,00 80,00 100,00

Serie:

- Carico - Corsa
- Carico - Deformazione
- Formula - Corsa
- Formula - Deformazione

Puntata:

- Carico - Corsa
- Carico - Deformazione
- Formula - Corsa
- Formula - Deformazione

Soglie:

- Carico - Corsa
- Carico - Deformazione
- Formula - Corsa
- Formula - Deformazione

COMPRESSION TESTING MACHINES, FOUR COLUMNS PRESTRESSED FRAME FOR PRODUCTION ROUTINE TESTS

(Models described at pag. 168 ÷ 197)

STANDARDS: ASTM C39 / BS 1610 / NF P18-411 / UNE 83304 / AASHTO T22 / UNI 6686 part 1 and 2

Technical features:

- Compression platens are hardened over 55 HRC and rectified.
- Device to check piston's excursion during test.
- The columns are prestressed to provide a very high rigidity.
- Piston having 50 mm stroke and cylinder are coupled with high quality packing set.
- The tank is foreseen of oil level and oil discharge.
- Dial speed selector to visualize, pre-select and control the oil flow.
- Power pump is multipiston assuring continuity of delivery.
- Fast approach ram device to avoid dead times.
- Ball seating is accurately machined.

Available in the following capacities:

1300 kN / 1500 kN / 2000 kN / 2000 kN BLOCKS / 3000 kN / 3000 kN BLOCKS / 5000 kN

Motorized or hand operated models.

Load measuring system: bourdon type gauges, "DIGITEC" or "CYBERTRONIC" graphic display units, "AUTOTEC" or "SERVO-PLUS EVOLUTION" servo-controlled automatic systems.



COMPRESSION TESTING MACHINE 1300 kN CAPACITY

To test cylinders up to dia. 160x320 mm and cubes up to 150 mm side

STANDARDS: ASTM C39 / AASHTO T22 / UNI 6686 part 1 and 2
NF P18-411 / BS 1610 / UNE 83304

TECHNICAL SPECIFICATIONS:

- Max. vertical daylight: 336 mm
- Compression platens dia. 216 mm
- Gauges dia. 250 mm with specific resistance scales for cubes 150 mm and cylinders dia. 150 - 160 mm
- Gauges divisions: 1300 kN div. 4 kN - 600 kN div. 2 kN
- Hydraulic device to stop the piston's stroke at its max excursion to avoid pumping the piston out of the cylinder.
- Calibration accuracy: Grade 1.0
- Max. ram travel 55 mm approx.
- Power supply (motorized models): 230V 1 ph 50 Hz 750 W
- Dimensions: 630x350x1260 mm
- Weight: 540÷580 kg

section C



168



C020 + C111 + C126



C022 + C111



C024D + C127N + C121



C025A + C127N + C121

COMPRESSION 1300 kN capacity

Model	Hand Operated	Motorized	LOAD MEASURING SYSTEM			
			1 Gauge	2 Gauge	Digitec mod. C108N (pag. 155)	Autotec mod. C098N (pag. 155)
C020	•		•			
C021	•			•		
C022		•	•			
C023		•		•		
C024 D		•			•	
C025 A		•				•

MATEST

ACCESSORIES FOR 1300 kN MACHINES:

- C111-30** DISTANCE PIECE, 20 mm high for cylinders Ø 150x300 mm
 - C111** DISTANCE PIECE, 176 high for cubes 150 mm side
 - C111-01** DISTANCE PIECES, 176+50 mm high for cubes 150 and 100 mm side
 - C111-03** DISTANCE PIECE, 100 high for cylinders Ø 110x220 mm
 - C111-03 + C111-30** DISTANCE PIECES, 100 + 20 mm high for cylinders Ø 100x200 mm
 - C111-21** DISTANCE PIECE, 50 mm high
- Note: the cylinders Ø 160x320 mm do not require any distance piece.
- C127N** GRAPHIC PRINTER on thermo-paper on board for digital models
 - C127-II** THERMO-PAPER roll for printer (pack of 10 rolls)

- C109-10** SOFTWARE for compression tests with Digitec machine. See pag. 14
- C123** SOFTWARE "servonet" for remote control through PC of Autotec machine. See pag. 14
- C119** FRAGMENT GUARDS, to CE Directive. See pag. 244
- C121** SAFETY GUARDS, polycarbonate, with hinges and lock, to CE Directive. See pag. 244
- C121-51** STOP SWITCH on safety guard. See pag. 244

C041-11
TESTING CHAMBER with vertical clearance of 376 mm, complete with distance piece 40 mm high, that allows to test cylinders dia. 150x300mm and 160x320mm with "capping retainers" (ASTM C1231)

- C107-10** CAPPING RETAINERS (set of two) for cylinders 150mm and 6"
- C107-12** CAPPING RETAINERS (set of two) for cylinders Ø 160mm
- C107-20** NEOPRENE PADS (set of two) for cylinders Ø 150mm 60 shore A

- C107-21** NEOPRENE PADS (set of two) for cylinders Ø 150mm 70 shore A
- C107-25** NEOPRENE PADS (set of two) for cylinders Ø 160mm 60 shore A



- C107-26** NEOPRENE PADS (set of two) for cylinders Ø 160mm 70 shore A
- Note: The capping retainers can be used only with the testing chamber having vertical clearance of 376 mm, mod. C041-11
Technical details: see pag. 243

- C115-01**
TWO WAY HYDRAULIC VALVE, connected to the motorized pumping unit of the machine to activate a second frame.
Technical details: see pag. 245



C097-05
CLASS 1, starting from 1% of the full range. With a special calibration procedure it is possible to grant Class 1 practically on the full range of the compression machine. Applicable only on digital machines.

C097-01
DUAL LOW CAPACITY DIGITAL RANGE, complete with "appropriate pressure transducer", only for digital machines. Recommended range 0-250kN. Technical details: see pag. 240
AS AN ALTERNATIVE:

C097-02
DUAL LOW CAPACITY DIGITAL RANGE 0-300kN, complete with "strain gage load cell", only for digital machines. Technical details: see pag. 240

C107
AUTO-CENTERING DEVICE for cubes 100 and 150 mm side, and cylinders dia. 100 and 150 mm. Technical details: see pag. 243

C100
SPLITTING TENSILE test device for cylinders. EN 12390-6 / ASTM C496
Technical details and other models: see pag. 241



C103
SPLITTING TENSILE test device for self blocking pavers and cubes. EN 1338, 12390-6. Technical details: see pag. 241

C109-12
SOFTWARE for splitting tensile tests with digital machines. Technical details. See pag. 14



C106
FLEXURAL TEST DEVICE for concrete beams. EN 12390-5 / ASTM C78, C293 / AASHTO T97 / BS1881:118 NF P18-407 / UNI 6133. Technical details: see pag. 242

C109-11
SOFTWARE for flexural tests on concrete beams with digital machines. Technical details: see pag. 14



E170
COMPRESSION DEVICE to test cement specimens 40,1 x 40 mm. EN 196 / ASTM C349
Technical details and other models: see pag. 242



C126
BENCH to hold the compression machine. See pag. 244



C097-01

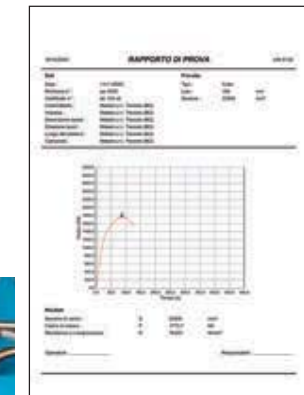

C109-10 Software Compression



COMPRESSION TESTING MACHINE 1300 kN CAPACITY

To test cylinders up to dia. 160x320 mm and cubes up to 150 mm side

Cyber-Plus or Servo-Plus Evolution Touch Screen Digital System

STANDARDS: ASTM C39 / AASHTO T22 / UNI 6686 part 1 and 2
NF P18-411 / BS 1610 / UNE 83304

TECHNICAL SPECIFICATIONS:

- Max. vertical daylight: 336 mm
- Compression platens dia. 216 mm
- Hydraulic device to stop the piston's stroke at its max excursion to avoid pumping the piston out of the cylinder.
- Calibration accuracy: Grade 1.0
- Max. ram travel 55 mm approx.
- Power supply: 230V 1 ph 50 Hz 750 W
- Dimensions: 630x350x1260 mm
- Weight: 540÷580 kg



C025N + C127N + C121 + C121-51 + C111 + C126



ACCESSORIES: C024N + C127N + C121

C104-04

CONSOLE HOUSING THE SERVO-PLUS EVOLUTION

The pump assembly and the digital system are encased to enhance the design and look of the machine.

C104-05

ONLINE REMOTE ASSISTANCE PACKAGE

The machine features a connection to Internet through which Matest Customer Service provides real time support to analyze the problem, to find possible solution, and to carry out a proper test execution.



C025N + C104-04 + C127N + C111-01

COMPRESSION 1300 kN capacity

LOAD MEASURING SYSTEM

Model	Motorized	Cyber-Plus Evolution mod. C109N (pag. 158)	Servo-Plus Evolution mod. C104N (pag. 158)
C024 N	•	•	
C025 N	•		•

section C



170

MATEST

ACCESSORIES FOR 1300 kN MACHINES:

- C111-30** DISTANCE PIECE, 20 mm high for cylinders Ø 150x300 mm
 - C111** DISTANCE PIECE, 176 high for cubes 150 mm side
 - C111-01** DISTANCE PIECES, 176+50 mm high for cubes 150 and 100 mm side
 - C111-03** DISTANCE PIECE, 100 high for cylinders Ø 110x220 mm
 - C111-03 + C111-30** DISTANCE PIECES, 100 + 20 mm high for cylinders Ø 100x200 mm
 - C111-21** DISTANCE PIECE, 50 mm high
- Note: the cylinders Ø 160x320 mm do not require any distance piece.
- C127N** GRAPHIC PRINTER on thermo-paper on board
 - C127-11** THERMO-PAPER roll for printer (pack of 10 rolls)

- C109-10N** SOFTWARE for compression tests with Cyber-Plus Evolution machine. See pag. 14
- C123N** SOFTWARE "servonet" for remote control through PC of Servo-Plus Evolution machine. See pag. 14
- C119** FRAGMENT GUARDS, to CE Directive. See pag. 244
- C121** SAFETY GUARDS, polycarbonate, with hinges and lock, to CE Directive. See pag. 244
- C121-51** STOP SWITCH on safety guard. See pag. 244

C041-11
TESTING CHAMBER with vertical clearance of 376 mm, complete with distance piece 40 mm high, that allows to test cylinders dia. 150x300mm and 160x320mm with "capping retainers" (ASTM C1231)

- C107-10** CAPPING RETAINERS (set of two) for cylinders 150mm and 6"
- C107-12** CAPPING RETAINERS (set of two) for cylinders Ø 160mm
- C107-20** NEOPRENE PADS (set of two) for cylinders Ø 150mm 60 shore A

- C107-21** NEOPRENE PADS (set of two) for cylinders Ø 150mm 70 shore A
- C107-25** NEOPRENE PADS (set of two) for cylinders Ø 160mm 60 shore A
- C107-26** NEOPRENE PADS (set of two) for cylinders Ø 160mm 70 shore A



C107-10

Note: The capping retainers can be used only with the testing chamber having vertical clearance of 376 mm, mod. C041-11
Technical details: see pag. 243

- C115-01**
TWO WAY HYDRAULIC VALVE, connected to the motorized pumping unit of the machine to activate a second frame.
Technical details: see pag. 245



C115-01

C097-05
CLASS 1, starting from 1% of the full range. With a special calibration procedure it is possible to grant Class 1 practically on the full range of the compression machine.

C097-01
DUAL LOW CAPACITY DIGITAL RANGE, complete with "appropriate pressure transducer".
Recommended range 0-250kN. Technical details: see pag. 240
AS AN ALTERNATIVE:

C097-02
DUAL LOW CAPACITY DIGITAL RANGE 0-300kN, complete with "strain gage load cell".
Technical details: see pag. 240

C107
AUTO-CENTERING DEVICE for cubes 100 and 150 mm side, and cylinders dia. 100 and 150 mm. Technical details: see pag. 243

C100
SPLITTING TENSILE test device for cylinders. EN 12390-6 / ASTM C496
Technical details and other models: see pag. 241



C100

C103
SPLITTING TENSILE test device for self blocking pavers and cubes. EN 1338, 12390-6. Technical details: see pag. 241

C109-12N
SOFTWARE for splitting tensile tests.
Technical details. See pag. 14



C103

C106
FLEXURAL TEST DEVICE for concrete beams. EN 12390-5 / ASTM C78, C293 / AASHTO T97 / BS1881:118 NF P18-407 / UNI 6133.
Technical details: see pag. 242



C106

C109-11N
SOFTWARE for flexural tests on concrete beams.
Technical details: see pag. 14

E170
COMPRESSION DEVICE to test cement specimens 40,1 x 40 mm. EN 196 / ASTM C349
Technical details and other models: see pag. 242



E170

C126
BENCH to hold the compression machine.
See pag. 244



C097-01



C109-10N Software Compression



COMPRESSION TESTING MACHINE 1500 kN CAPACITY
To test cubes up to 150 mm side and cylinders up to dia. 160x320 mm

STANDARDS: ASTM C39 / AASHTO T22 / UNI 6686 part I and 2 / NF P18-411 / BS 1610 / UNE 83304

TECHNICAL SPECIFICATIONS:

- Max. vertical daylight: 336 mm
- Compression platens dia. 216 mm
- Gauges dia. 250 mm with specific resistance scales for cubes 150 mm and cylinders dia. 150 and 160 mm
- Gauges divisions: 1500 kN div. 5 kN - 600 kN div. 2 kN
- Hydraulic device to stop the piston's stroke at its max excursion to avoid pumping the piston out of the cylinder.
- Calibration accuracy: Grade 1.0
- Max. ram travel 55 mm approx.
- Power supply (motorized models): 230V 1 ph 50 Hz 750 W
- Dimensions: 630x350x1260 mm
- Weight: 540÷580 kg

section C



172



C041A + C127N + C121



C040D + C127N + C121



C038 + C126 + C111

COMPRESSION 1500 kN capacity

Model	Hand Operated	Motorized	LOAD MEASURING SYSTEM			
			1 Gauge	2 Gauge	Digitec mod. C108N (pag. 155)	Autotec mod. C098N (pag. 155)
C036	•		•			
C037	•			•		
C038		•	•			
C039		•		•		
C040 D		•			•	
C041 A		•				•

MATEST

ACCESSORIES FOR 1500 kN MACHINES:

- C111-30** DISTANCE PIECE, 20 mm high for cylinders Ø 150x300 mm
 - C111** DISTANCE PIECE, 176 high for cubes 150 mm side
 - C111-01** DISTANCE PIECES, 176+50 mm high for cubes 150 and 100 mm side
 - C111-03** DISTANCE PIECE, 100 high for cylinders Ø 110x220 mm
 - C111-03 + C111-30** DISTANCE PIECES, 100 + 20 mm high for cylinders Ø 100x200 mm
 - C111-21** DISTANCE PIECE, 50 mm high
- Note: the cylinders Ø 160x320 mm do not require any distance piece.
- C127N** GRAPHIC PRINTER on thermo-paper on board for digital models
 - C127-11** THERMO-PAPER roll for printer (pack of 10 rolls)

- C109-10** SOFTWARE for compression tests with Digitec machine. See pag. 14
- C123** SOFTWARE "servonet" for remote control through PC of Autotec machine. See pag. 14
- C119** FRAGMENT GUARDS, to CE Directive. See pag. 244
- C121** SAFETY GUARDS, polycarbonate, with hinges and lock, to CE Directive. See pag. 244
- C121-51** STOP SWITCH on safety guard. See pag. 244

- C041-11**
TESTING CHAMBER with vertical clearance of 376 mm, complete with distance piece 40 mm high, that allows to test cylinders dia. 150x300mm and 160x320mm with "capping retainers" (ASTM C1231)

- C107-10** CAPPING RETAINERS (set of two) for cylinders 150mm and 6"
- C107-12** CAPPING RETAINERS (set of two) for cylinders Ø 160mm
- C107-20** NEOPRENE PADS (set of two) for cylinders Ø 150mm 60 shore A

- C107-21** NEOPRENE PADS (set of two) for cylinders Ø 150mm 70 shore A
- C107-25** NEOPRENE PADS (set of two) for cylinders Ø 160mm 60 shore A

- C107-26** NEOPRENE PADS (set of two) for cylinders Ø 160mm 70 shore A

Note: The capping retainers can be used only with the testing chamber having vertical clearance of 376 mm, mod. C041-11
Technical details: see pag. 243

- C115-01**
TWO WAY HYDRAULIC VALVE, connected to the motorized pumping unit of the machine to activate a second frame.
Technical details: see pag. 245



C115-01

- C097-05**
CLASS 1, starting from 1% of the full range. With a special calibration procedure it is possible to grant Class 1 practically on the full range of the compression machine. Applicable only on digital machines.

- C097-01**
DUAL LOW CAPACITY DIGITAL RANGE, complete with "appropriate pressure transducer", only for digital machines. Recommended range 0-250kN. Technical details: see pag. 240
AS AN ALTERNATIVE:

- C097-02**
DUAL LOW CAPACITY DIGITAL RANGE 0-300kN, complete with "strain gage load cell", only for digital machines. Technical details: see pag. 240

- C107**
AUTO-CENTERING DEVICE for cubes 100 and 150 mm side, and cylinders dia. 100 and 150 mm. Technical details: see pag. 243

- C100**
SPLITTING TENSILE test device for cylinders. EN 12390-6 / ASTM C496
Technical details and other models: see pag. 241



C100

- C103**
SPLITTING TENSILE test device for self blocking pavers and cubes. EN 1338, 12390-6. Technical details: see pag. 241



C103

- C109-12**
SOFTWARE for splitting tensile tests with digital machines.
Technical details. See pag. 14

- C106**
FLEXURAL TEST DEVICE for concrete beams. EN 12390-5 / ASTM C78, C293 / AASHTO T97 / BS1881:118 NF P18-407 / UNI 6133.
Technical details: see pag. 242



C106

- C109-11**
SOFTWARE for flexural tests on concrete beams with digital machines. Technical details: see pag. 14

- E170**
COMPRESSION DEVICE to test cement specimens 40,1 x 40 mm. EN 196 / ASTM C349
Technical details and other models: see pag. 242



E170

- C126**
BENCH to hold the compression machine.
See pag. 244



C097-01



C109-10 Software Compression



COMPRESSION TESTING MACHINE 1500 kN CAPACITY
To test cubes up to 150 mm side and cylinders up to dia. 160x320 mm
Cyber-Plus or Servo-Plus Evolution Touch Screen Digital System

STANDARDS: ASTM C39 / AASHTO T22 / UNI 6686 part 1 and 2 / NF P18-411 / BS 1610 / UNE 83304

TECHNICAL SPECIFICATIONS:

- Max. vertical daylight: 336 mm
- Compression platens dia. 216 mm
- Hydraulic device to stop the piston's stroke at its max excursion to avoid pumping the piston out of the cylinder.
- Calibration accuracy: Grade 1.0
- Max. ram travel 55 mm approx.
- Power supply: 230V 1 ph 50 Hz 750 W
- Dimensions: 630x350x1260 mm
- Weight: 540÷580 kg



section C



174



C041N + C104-04 + C127N + C111



C041N + C127N + C121



C040N + C127N + C111-01

ACCESSORIES:

C104-04

CONSOLE HOUSING THE SERVO-PLUS EVOLUTION

The pump assembly and the digital system are encased to enhance the design and look of the machine.

C104-05

ONLINE REMOTE ASSISTANCE PACKAGE

The machine features a connection to Internet through which Matest Customer Service provides real time support to analyze the problem, to find possible solution, and to carry out a proper test execution.

COMPRESSION 1500 kN capacity

LOAD MEASURING SYSTEM

Model	Motorized	Cyber-Plus Evolution mod. C109N (pag. 158)	Servo-Plus Evolution mod. C104N (pag. 158)
C040 N	•	•	
C041 N	•		•

MATEST

ACCESSORIES FOR 1500 kN MACHINES:

- C111-30** DISTANCE PIECE, 20 mm high for cylinders Ø 150x300 mm
- C111** DISTANCE PIECE, 176 high for cubes 150 mm side
- C111-01** DISTANCE PIECES, 176+50 mm high for cubes 150 and 100 mm side

- C111-03** DISTANCE PIECE, 100 high for cylinders Ø 110x220 mm
- C111-03 + C111-30** DISTANCE PIECES, 100 + 20 mm high for cylinders Ø 100x200 mm

- C111-21** DISTANCE PIECE, 50 mm high
- Note: the cylinders Ø 160x320 mm do not require any distance piece.

- C127N** GRAPHIC PRINTER on thermo-paper on board
- C127-11** THERMO-PAPER roll for printer (pack of 10 rolls)

- C109-10N** SOFTWARE for compression tests with Cyber-Plus Evolution machine. See pag. 14

- C123N** SOFTWARE "servonet" for remote control through PC of Servo-Plus Evolution machine. See pag. 14

- C119** FRAGMENT GUARDS, to CE Directive. See pag. 244
- C121** SAFETY GUARDS, polycarbonate, with hinges and lock, to CE Directive. See pag. 244

- C121-51** STOP SWITCH on safety guard. See pag. 244

- C041-11** TESTING CHAMBER with vertical clearance of 376 mm, complete with distance piece 40 mm high, that allows to test cylinders dia. 150x300mm and 160x320mm with "capping retainers" (ASTM C1231)

- C107-10** CAPPING RETAINERS (set of two) for cylinders 150mm and 6"
- C107-12** CAPPING RETAINERS (set of two) for cylinders Ø 160mm
- C107-20** NEOPRENE PADS (set of two) for cylinders Ø 150mm 60 shore A

- C107-21** NEOPRENE PADS (set of two) for cylinders Ø 150mm 70 shore A

- C107-25** NEOPRENE PADS (set of two) for cylinders Ø 160mm 60 shore A

- C107-26** NEOPRENE PADS (set of two) for cylinders Ø 160mm 70 shore A

Note: The capping retainers can be used only with the testing chamber having vertical clearance of 376 mm, mod. C041-11
 Technical details: see pag. 243

- C115-01** TWO WAY HYDRAULIC VALVE, connected to the motorized pumping unit of the machine to activate a second frame.
 Technical details: see pag. 245



- C097-05** CLASS 1, starting from 1% of the full range. With a special calibration procedure it is possible to grant Class 1 practically on the full range of the compression machine.

- C097-01** DUAL LOW CAPACITY DIGITAL RANGE, complete with "appropriate pressure transducer".
 Recommended range 0-250kN. Technical details: see pag. 240
 AS AN ALTERNATIVE:

- C097-02** DUAL LOW CAPACITY DIGITAL RANGE 0-300kN, complete with "strain gage load cell". Technical details: see pag. 240

- C107** AUTO-CENTERING DEVICE for cubes 100 and 150 mm side, and cylinders dia. 100 and 150 mm. Technical details: see pag. 243

- C100** SPLITTING TENSILE test device for cylinders. EN 12390-6 / ASTM C496
 Technical details and other models: see pag. 241



- C103** SPLITTING TENSILE test device for self blocking pavers and cubes. EN 1338, 12390-6. Technical details: see pag. 241



- C109-12N** SOFTWARE for splitting tensile tests.
 Technical details. See pag. 14

- C106** FLEXURAL TEST DEVICE for concrete beams. EN 12390-5 / ASTM C78, C293 / AASHTO T97 / BS1881:118 NF P18-407 / UNI 6133.
 Technical details: see pag. 242



- C109-11N** SOFTWARE for flexural tests on concrete beams.
 Technical details: see pag. 14

- E170** COMPRESSION DEVICE to test cement specimens 40,1 x 40 mm. EN 196 / ASTM C349
 Technical details and other models: see pag. 242



- C126** BENCH to hold the compression machine.
 See pag. 244



C097-01

C109-10N Software Compression



COMPRESSION TESTING MACHINE 2000 kN CAPACITY

To test cubes up to 150 mm side and cylinders up to dia. 160x320 mm

STANDARDS: ASTM C39 / AASHTO T22 / UNI 6686 part 1 and 2 / NF P18-411 / BS 1610 / UNE 83304

TECHNICAL SPECIFICATIONS:

- Max. vertical daylight: 336 mm
- Compression platens dia. 216 mm
- Gauges dia. 250 mm with specific resistance scales for cubes 150 mm and cylinders dia. 150 and 160 mm
- Gauges divisions: 2000 kN div. 5 kN - 600 kN div. 2 kN
- Hydraulic device to stop the piston's stroke at its max excursion to avoid pumping the piston out of the cylinder.
- Calibration accuracy: Grade 1.0
- Max. ram travel 55 mm approx.
- Power supply (motor models): 230V 1 ph 50 Hz 750 W
- Dimensions: 690x400x1320 mm
- Weight: 650÷700 kg

section C



176



C055D + C127N + C111



C056A + C127N - C111



C053 + C119-03

COMPRESSION 2000 kN capacity

Model	Hand Operated	Motorized	LOAD MEASURING SYSTEM			
			1 Gauge	2 Gauge	Digitec mod. C108N (pag. 155)	Autotec mod. C098N (pag. 155)
C051	•		•			
C052	•			•		
C053		•	•			
C054		•		•		
C055 D		•			•	
C056 A		•				•

MATEST

ACCESSORIES FOR 2000 kN MACHINES:

C111-30 DISTANCE PIECE, 20 mm high for cylinders Ø 150x300 mm

C111 DISTANCE PIECE, 176 high for cubes 150 mm side

C111-01 DISTANCE PIECES 176+50 mm high for cubes 150 and 100 mm side

C111-03 DISTANCE PIECE, 100 mm high for cylinders Ø 110x220 mm

C111-03 + C111-30 DISTANCE PIECES 100 + 20 mm high for cylinders Ø 100x200 mm

C111-21 DISTANCE PIECE 50 mm high

Note: the cylinders dia. 160x320 mm do not require any distance piece.

C112-10 UPPER+LOWER LARGE COMPRESSION PLATENS 245x510x55 mm WITH SEAT BALL to test "also" blocks and cubes 200 mm side

C127N GRAPHIC PRINTER on thermo-paper on board for digital models

C127-11 THERMO-PAPER roll for printer (pack of 10 rolls)

C109-10 SOFTWARE for compression tests with Digitec machine. See pag. 14

C123 SOFTWARE "servonet" for remote control through PC of Autotec machine. See pag. 14

C119-03 FRAGMENT GUARDS, to CE Directive. See pag. 244

C121-05 SAFETY GUARDS, polycarbonate, with hinges and lock, to CE Directive. See pag. 244

C121-51 STOP SWITCH on safety guard. See pag. 244

C056-11

TESTING CHAMBER with vertical clearance of 376 mm, complete with distance piece 40 mm high, that allows to test cylinders dia. 150x300mm and 160x320mm with "capping retainers" (ASTM C1231)

C107-10 CAPPING RETAINERS (set of two) for cylinders 150mm and 6"

C107-12 CAPPING RETAINERS (set of two) for cylinders Ø 160mm

C107-20 NEOPRENE PADS (set of two) for cylinders Ø 150mm 60 shore A

C107-25 NEOPRENE PADS (set of two) for cylinders Ø 160mm 60 shore A

Note: The capping retainers can be used only with the testing chamber having vertical clearance of 376 mm, mod. C056-11
Technical details: see pag. 243



C107-10

C115-01

TWO WAY HYDRAULIC VALVE, connected to the motorized pumping unit of the machine to activate a second frame.
Technical details: see pag. 245



C115-01

C097-05

CLASS 1, starting from 1% of the full range. With a special calibration procedure it is possible to grant Class 1 practically on the full range of the compression machine. Applicable only on digital machines.

C097-01

DUAL LOW CAPACITY DIGITAL RANGE, complete with "appropriate pressure transducer", only for digital machines. Recommended range 0-250kN. Technical details: see pag. 240

AS AN ALTERNATIVE:

C097-02

DUAL LOW CAPACITY DIGITAL RANGE 0-300kN, complete with "strain gage load cell", only for digital machines. Technical details: see pag. 240

C107

AUTO-CENTERING DEVICE for cubes 100 and 150 mm side and cylinders dia. 100 and 150 mm. Technical details: see pag. 243

C100

SPLITTING TENSILE test device for cylinders. EN 12390-6 / ASTM C496
Technical details and other models: see pag. 241



C100

C103

SPLITTING TENSILE test device for self blocking pavers and cubes. EN 1338, 12390-6. Technical details: see pag. 241

C109-12

SOFTWARE for splitting tensile tests with digital machines.
Technical details: see pag. 14



C103

C106

FLEXURAL TEST DEVICE for concrete beams. EN 12390-5 / ASTM C78, C293 / AASHTO T97 / BS 1881:118 / NF P18-407 / UNI 6133
Technical details: see pag. 242



C106

C109-11

SOFTWARE for flexural tests on concrete beams with digital machines. Technical details: see pag. 14

E170

COMPRESSION DEVICE to test cement specimens 40,1 x 40 mm. EN 196 / ASTM C349. Technical details and other models: see pag. 242



E170

C126

BENCH to hold the compression machine.
See pag. 244



C097-01



C109-10 Software Compression



COMPRESSION TESTING MACHINE 2000 kN CAPACITY
To test cubes up to 150 mm side and cylinders up to dia. 160x320 mm.

Cyber-Plus or Servo-Plus Evolution Touch Screen Digital System

STANDARDS: ASTM C39 / AASHTO T22 / UNI 6686 part I and 2 / NF P18-411 / BS 1610 / UNE 83304

TECHNICAL SPECIFICATIONS:

- Max. vertical daylight: 336 mm
- Compression platens dia. 216 mm
- Hydraulic device to stop the piston's stroke at its max excursion to avoid pumping the piston out of the cylinder.
- Calibration accuracy: Grade 1.0
- Max. ram travel 55 mm approx.
- Power supply: 230V 1 ph 50 Hz 750 W
- Dimensions: 690x400x1320 mm
- Weight: 650÷700 kg



section C



178



C055N + C127N



C056N + C127N + C121-05

C104-04

ACCESSORIES:

C104-04

CONSOLE HOUSING THE SERVO-PLUS EVOLUTION

The pump assembly and the digital system are encased to enhance the design and look of the machine.

C104-05

ONLINE REMOTE ASSISTANCE PACKAGE

The machine features a connection to Internet through which Matest Customer Service provides real time support to analyze the problem, to find possible solution, and to carry out a proper test execution.



C056N + C127N + C111

COMPRESSION 2000 kN capacity

LOAD MEASURING SYSTEM

Model	Motorized	Cyber-Plus Evolution mod. C109N (pag. 158)	Servo-Plus Evolution mod. C104N (pag. 158)
C055 N	•	•	
C056 N	•		•

MATEST

ACCESSORIES FOR 2000 kN MACHINES:

- C111-30** DISTANCE PIECE, 20 mm high for cylinders Ø 150x300 mm
 - C111** DISTANCE PIECE, 176 high for cubes 150 mm side
 - C111-01** DISTANCE PIECES 176+50 mm high for cubes 150 and 100 mm side
 - C111-03** DISTANCE PIECE, 100 mm high for cylinders Ø 110x220 mm
 - C111-03 + C111-30** DISTANCE PIECES 100 + 20 mm high for cylinders Ø 100x200 mm
 - C111-21** DISTANCE PIECE 50 mm high
- Note: the cylinders dia. 160x320 mm do not require any distance piece.

C112-10 UPPER+LOWER LARGE COMPRESSION PLATENS 245x510x55 mm WITH SEAT BALL to test "also" blocks and cubes 200 mm side

C127N GRAPHIC PRINTER on thermo-paper on board

C127-11 THERMO-PAPER roll for printer (pack of 10 rolls)

C109-10N SOFTWARE for compression tests with Cyber-Plus Evolution machine. See pag. 14

C123N SOFTWARE "servonet" for remote control through PC of Servo-Plus Evolution machine. See pag. 14

C119-03 FRAGMENT GUARDS, to CE Directive. See pag. 244

C121-05 SAFETY GUARDS, polycarbonate, with hinges and lock, to CE Directive. See pag. 244

C121-51 STOP SWITCH on safety guard. See pag. 244

C056-11

TESTING CHAMBER with vertical clearance of 376 mm, complete with distance piece 40 mm high, that allows to test cylinders dia. 150x300mm and 160x320mm with "capping retainers" (ASTM C1231)

C107-10 CAPPING RETAINERS (set of two) for cylinders 150mm and 6"

C107-12 CAPPING RETAINERS (set of two) for cylinders Ø 160mm

C107-20 NEOPRENE PADS (set of two) for cylinders Ø 150mm 60 shore A

C107-25 NEOPRENE PADS (set of two) for cylinders Ø 160mm 60 shore A

Note: The capping retainers can be used only with the testing chamber having vertical clearance of 376 mm, mod. C056-11
Technical details: see pag. 243



C107-10

C115-01

TWO WAY HYDRAULIC VALVE, connected to the motorized pumping unit of the machine to activate a second frame.
Technical details: see pag. 245



C115-01

C097-05

CLASS 1, starting from 1% of the full range. With a special calibration procedure it is possible to grant Class 1 practically on the full range of the compression machine.

C097-01

DUAL LOW CAPACITY DIGITAL RANGE, complete with "appropriate pressure transducer". Recommended range 0-250kN.
Technical details: see pag. 240

AS AN ALTERNATIVE:

C097-02

DUAL LOW CAPACITY DIGITAL RANGE 0-300kN, complete with "strain gage load cell".
Technical details: see pag. 240

C107

AUTO-CENTERING DEVICE for cubes 100 and 150 mm side and cylinders dia. 100 and 150 mm. Technical details: see pag. 243

C100

SPLITTING TENSILE test device for cylinders. EN 12390-6 / ASTM C496
Technical details and other models: see pag. 241



C100

C103

SPLITTING TENSILE test device for self blocking pavers and cubes. EN 1338, 12390-6. Technical details: see pag. 241

C109-12N

SOFTWARE for splitting tensile tests.
Technical details: see pag. 14



C103

C106

FLEXURAL TEST DEVICE for concrete beams. EN 12390-5 / ASTM C78, C293 / AASHTO T97 / BS 1881:118 / NF P18-407 / UNI 6133
Technical details: see pag. 242



C106

C109-11N

SOFTWARE for flexural tests on concrete beams.
Technical details: see pag. 14

E170

COMPRESSION DEVICE to test cement specimens 40,1 x 40 mm. EN 196 / ASTM C349. Technical details and other models: see pag. 242



E170

C126

BENCH to hold the compression machine.
See pag. 244



C097-01



C109-10N Software Compression



COMPRESSION TESTING MACHINE 2000 kN CAPACITY

To test cubes up to 200 mm side and cylinders up to 280 mm height

STANDARDS: ASTM C39 / AASHTO T22 / UNI 6686 part 1 and 2 / NF P18-411 / BS 1610
UNE 83304

TECHNICAL SPECIFICATIONS:

- Max. vertical daylight: 282 mm
- Compression platens dia. 287 mm
- Gauges dia. 250 mm with specific resistance scales for cubes 150 mm and cylinders dia. 150 and 160 mm
- Gauges divisions: 2000 kN div. 5 kN - 600 kN div. 2 kN
- Hydraulic device to stop the piston's stroke at its max excursion to avoid pumping the piston out of the cylinder.
- Calibration accuracy: Grade 1.0
- Max. ram travel 55 mm approx.
- Power supply (motor models): 230V 1 ph 50 Hz 750 W
- Dimensions: 690x400x1320 mm
- Weight: 670÷720 kg

section C



180



C058-05A + C127N + C111-26



C058-04D + C127N + C111-26



C058-03 + C126

COMPRESSION 2000 kN capacity

Model	Hand Operated	Motorized	LOAD MEASURING SYSTEM			
			1 Gauge	2 Gauge	Digitec mod. C108N (pag. 155)	Autotec mod. C098N (pag. 155)
C058	•		•			
C058-01	•			•		
C058-02		•	•			
C058-03		•		•		
C058-04 D		•			•	
C058-05 A		•				•

MATEST

ACCESSORIES FOR 2000 kN MACHINES:

C111-26 DISTANCE PIECE, 76 mm high for cubes 200 mm side

C111-26 + C111-22

DISTANCE PIECES, 76+50 mm high for cubes 200 and 150 mm side

C111-26 + C111-22 + C111-22

DISTANCE PIECES 76+50+50 mm high for cubes 200, 150 and 100 mm side

C111-22 DISTANCE PIECE 50 mm high

C111-31

DISTANCE PIECE 20 mm high



C110-20

C110-20 LOWER COMPRESSION

PLATEN, hardened over 55 HRC, Ø 165x50 mm to test cubes 100 mm side (as an alternative to the distance piece 50 mm high)

Note: Cylinders having Ø 160 x 320 mm do not require any distance piece.

C112-10 UPPER+LOWER LARGE COMPRESSION PLATENS

245x510x55 mm WITH SEAT BALL to test "also" blocks.

C127N GRAPHIC PRINTER on thermo-paper on board for digital models

C127-11 THERMO-PAPER roll for printer (pack of 10 rolls)

C109-10 SOFTWARE for compression tests with Digitec machine. See pag. 14

C123 SOFTWARE "servonet" for remote control through PC of Autotec machine. See pag. 14

C119-03 FRAGMENT GUARDS, to CE Directive. See pag. 244

C121-05 SAFETY GUARDS, polycarbonate, with hinges and lock, to CE Directive. See pag. 244

C121-51

STOP SWITCH on safety guard. See pag. 244

C115-01

TWO WAY HYDRAULIC VALVE, connected to the motorized pumping unit of the machine to activate a second frame. Technical details: see pag. 245



C115-01

C097-01

DUAL LOW CAPACITY DIGITAL RANGE, complete with "appropriate pressure transducer", only for digital machines. Recommended range 0-250kN. Technical details: see pag. 240



C097-01

AS AN ALTERNATIVE:

C097-02

DUAL LOW CAPACITY DIGITAL RANGE 0-300kN, complete with "strain gage load cell", only for digital machines. Technical details: see pag. 240

C097-05

CLASS 1, starting from 1% of the full range. With a special calibration procedure it is possible to grant Class 1 practically on the full range of the compression machine. Applicable only on digital machines.

C107-01

AUTO-CENTERING DEVICE for cubes 100 and 150 mm side and cylinders dia. 100 mm Technical details: see pag. 243



C107-01

C100

SPLITTING TENSILE test device for cylinders. EN 12390-6 / ASTM C496 Technical details and other models: see pag. 241



C100

C103

SPLITTING TENSILE test device for self blocking pavers and cubes. EN 1338, 12390-6 Technical details: see pag. 241



C103

C109-12

SOFTWARE for splitting tensile tests with digital machines. Technical details: see pag. 14

C106

FLEXURAL TEST DEVICE for concrete beams. EN 12390-5 / ASTM C78, C293 / AASHTO T97 / BS 1881:118 / NF P18-407 / UNI 6133 Technical details: see pag. 242



C106

C109-11

SOFTWARE for flexural tests on concrete beams with digital machines. Technical details: see pag. 14

E170

COMPRESSION DEVICE to test cement specimens 40,1 x 40 mm. EN 196 / ASTM C349 Technical details and other models: see pag. 242



E170

C126

BENCH to hold the compression machine. See pag. 244

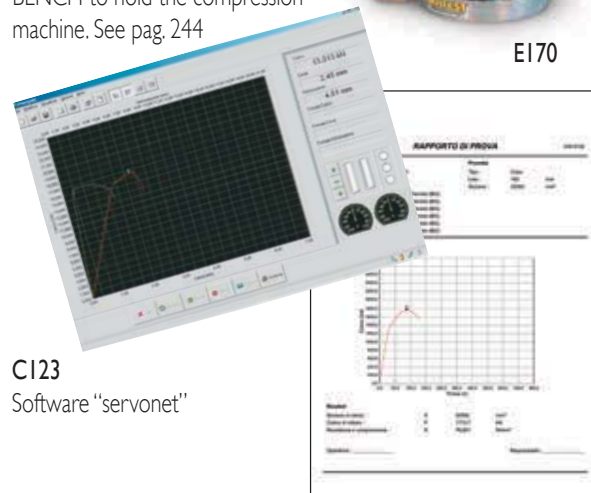

C123

Software "servonet"

C109-10 Software Compression



COMPRESSION TESTING MACHINE 2000 kN CAPACITY

To test cubes up to 200 mm side and cylinders up to 280 mm height

Cyber-Plus or Servo-Plus Evolution Touch Screen Digital System

STANDARDS: ASTM C39 / AASHTO T22 / UNI 6686 part I and 2 / NF P18-411 / BS 1610 / UNE 83304



TECHNICAL SPECIFICATIONS:

- Max. vertical daylight: 282 mm
- Compression platens dia. 287 mm
- Hydraulic device to stop the piston's stroke at its max excursion to avoid pumping the piston out of the cylinder.
- Calibration accuracy: Grade 1.0
- Max. ram travel 55 mm approx.
- Power supply : 230V 1 ph 50 Hz 750 W
- Dimensions: 690x400x1320 mm
- Weight: 670÷720 kg

section C



182



C058-05N + C104-04 + C127N + C111-26



C058-04N + C127N + C111-26



C058-05N + C127N

ACCESSORIES:

C104-04

CONSOLE HOUSING THE SERVO-PLUS EVOLUTION

The pump assembly and the digital system are encased to enhance the design and look of the machine.

C104-05

ONLINE REMOTE ASSISTANCE PACKAGE

The machine features a connection to Internet through which Matest Customer Service provides real time support to analyze the problem, to find possible solution, and to carry out a proper test execution.

COMPRESSION 2000 kN capacity

LOAD MEASURING SYSTEM

Model	Motorized	Cyber-Plus Evolution mod. C109N (pag. 158)	Servo-Plus Evolution mod. C104N (pag. 158)
C058-04 N	•	•	
C058-05 N	•		•

ACCESSORIES FOR 2000 kN MACHINES:

C111-26 DISTANCE PIECE, 76 mm high for cubes 200 mm side

C111-26 + C111-22

DISTANCE PIECES, 76+50 mm high for cubes 200 and 150 mm side

C111-26 + C111-22 + C111-22

DISTANCE PIECES 76+50+50 mm high for cubes 200, 150 and 100 mm side

C111-22 DISTANCE PIECE 50 mm high

C111-31

DISTANCE PIECE 20 mm high



C110-20

C110-20 LOWER COMPRESSION PLATEN, hardened over 55 HRC, Ø 165x50 mm to test cubes 100 mm side (as an alternative to the distance piece 50 mm high)

Note: Cylinders having Ø 160 x 320 mm do not require any distance piece.

C112-10 UPPER+LOWER LARGE COMPRESSION PLATENS 245x510x55 mm WITH SEAT BALL to test "also" blocks.

C127N GRAPHIC PRINTER on thermo-paper on board

C127-11 THERMO-PAPER roll for printer (pack of 10 rolls)

C109-10N SOFTWARE for compression tests with Cyber-Plus Evolution machine. See pag. 14

C123N SOFTWARE "servonet" for remote control through PC of Servo-Plus Evolution machine. See pag. 14

C119-03 FRAGMENT GUARDS, to CE Directive. See pag. 244

C121-05 SAFETY GUARDS, polycarbonate, with hinges and lock, to CE Directive. See pag. 244

C121-51 STOP SWITCH on safety guard. See pag. 244

C115-01

TWO WAY HYDRAULIC VALVE, connected to the motorized pumping unit of the machine to activate a second frame. Technical details: see pag. 245



C115-01

C097-01

DUAL LOW CAPACITY DIGITAL RANGE, complete with "appropriate pressure transducer".

Recommended range 0-250kN
Technical details: see pag. 240

AS AN ALTERNATIVE:

C097-02

DUAL LOW CAPACITY DIGITAL RANGE 0-300kN, complete with "strain gage load cell".

Technical details: see pag. 240



C097-01

C097-05

CLASS 1, starting from 1% of the full range. With a special calibration procedure it is possible to grant Class 1 practically on the full range of the compression machine.

C107-01

AUTO-CENTERING DEVICE for cubes 100 and 150 mm side and cylinders dia. 100 mm
Technical details: see pag. 243



C107-01

C100

SPLITTING TENSILE test device for cylinders. EN 12390-6 / ASTM C496
Technical details and other models: see pag. 241



C100

C103

SPLITTING TENSILE test device for self blocking pavers and cubes. EN 1338, 12390-6
Technical details: see pag. 241



C103

C109-12N

SOFTWARE for splitting tensile tests.
Technical details: see pag. 14

C106

FLEXURAL TEST DEVICE for concrete beams. EN 12390-5 / ASTM C78, C293 / AASHTO T97 / BS 1881:118 / NF P18-407 / UNI 6133
Technical details: see pag. 242



C106

C109-11N

SOFTWARE for flexural tests on concrete beams.
Technical details: see pag. 14

E170

COMPRESSION DEVICE to test cement specimens 40,1 x 40 mm. EN 196 / ASTM C349
Technical details and other models: see pag. 242



E170

C126

BENCH to hold the compression machine. Technical details: see pag. 244

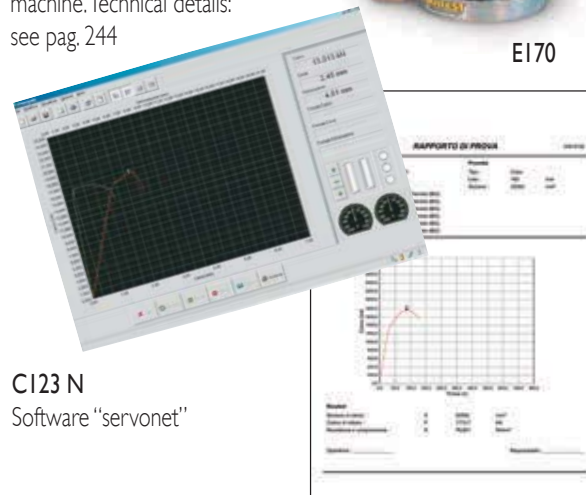

C123 N

Software "servonet"

C109-10N Software Compression

material testing equipment



COMPRESSION TESTING MACHINE 2000 kN CAPACITY

To test blocks max. 500x300 mm, cubes up to 300 mm side and cylinders up to dia. 160x320 mm

STANDARDS: EN 772-1 / ASTM C39, E447 / AASHTO T22 / UNI 6686 part 1 and 2 / NF P18-41 / BS 1610, 6073 / UNE 83304

TECHNICAL SPECIFICATIONS:

- Max. vertical daylight: 336 mm
- Compression platens 510x320x55 mm
- Gauges dia. 250 mm with specific resistance scales for cubes 150 mm and cylinders dia. 150 and 160 mm
- Gauges divisions: 2000 kN div. 5 kN
600 kN div. 2 kN
- Hydraulic device to stop the piston's stroke at its max excursion to avoid pumping the piston out of the cylinder
- Calibration accuracy: Grade 1.0
- Max. ram travel 55 mm approx.
- Power supply (motorized models): 230 V 1 ph 50 Hz 750 W
- Dimensions: 870x600x1400 mm
- Weight: 850÷900 kg

section C



184



C077D + C127N + C105 + C111-08 + C121-01



C078A + C127N + C105 + C111-08 + C121-01



C075 + C111-05 + C121-01

COMPRESSION 2000 kN capacity

Model	Hand Operated	Motorized	LOAD MEASURING SYSTEM			
			1 Gauge	2 Gauge	Digitec mod. C108N (pag. 155)	Autotec mod. C098N (pag. 155)
C073	•		•			
C074	•			•		
C075		•	•			
C076		•		•		
C077 D		•			•	
C078 A		•				•

MATEST

ACCESSORIES FOR 2000 kN BLOCKS MACHINES:

- C111-31** DISTANCE PIECE, 20 mm high for cylinders Ø 150x300 mm
 - C111-04** DISTANCE PIECE, 126 mm high for cubes 200 mm side
 - C111-05** DISTANCE PIECES, 126+50 mm high for cubes 200 and 150 mm side
 - C111-06** DISTANCE PIECES 126+50+50 mm high for cubes 200, 150 and 100 mm side
 - C111-22** DISTANCE PIECE 50 mm high
- Note: The cylinders Ø 160x320 mm do not require any distance piece.

C111-50

DISTANCE PIECE

It eliminates the heavy procedure to lift the lower rectangular platen and to add distance pieces.

Technical details: see pag. 247

AS AN ALTERNATIVE:

C112-05

KIT of 4 HANDLES to lift the lower platen, making the positioning of distance pieces easier. Technical details: see pag. 247

AS AN ALTERNATIVE:

- C105** CENTRAL SCREW, to get easier the adjustment between the big sized compression platens. Technical details: see pag. 240

- C111-27** SLOTTED DISTANCE PIECE, 20 mm high, for central screw
- C111-23** SLOTTED DISTANCE PIECE, 50 mm high for central screw
- C111-28** SLOTTED DISTANCE PIECE, 76 mm high for central screw
- C111-08** SLOTTED DISTANCE PIECE, 126 mm high for central screw

- C127N** GRAPHIC PRINTER on thermo-paper on board for digital models

- C127-11** THERMO-PAPER roll for printer (pack of 10 rolls)

- C109-10** SOFTWARE for compression tests with Digitec machine. See pag. 14

- C123** SOFTWARE "servonet" for remote control through PC of Autotec machine. See pag. 14

- C121-01** SAFETY GUARDS, polycarbonate, with hinges and lock, to CE Directive. See pag. 244

- C121-51** STOP SWITCH on safety guard. See pag. 244

- C107-10** CAPPING RETAINERS (set of two) for cylinders 150 mm and 6"

- C107-20** NEOPRENE PADS (set of two) for cylinders Ø150 mm 60 shore A

C110-30

UPPER COMPRESSION PLATEN+SPHERICAL SEAT, to fix on the testing machine, to obtain an increased vertical clearance of the testing chamber and to meet the ASTM C39 and AASHTO T22 Platen dimensions: dia. 165 x 30 mm Weight : 10 kg approx. Technical details: see pag. 243



C111-50

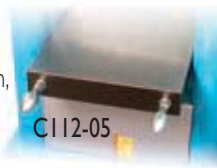

C112-05



C107-10



C110-30

C115-01

TWO WAY HYDRAULIC VALVE, connected to the motorized pumping unit of the machine to activate a second frame. Technical details: see pag. 245



C115-01

- C097-01** DUAL LOW CAPACITY DIGITAL RANGE, complete with "appropriate pressure transducer", only for digital machines. Recommended range 0-250kN. Technical details: see pag. 240

AS AN ALTERNATIVE:

- C097-02** DUAL LOW CAPACITY DIGITAL RANGE 0-300kN, complete with "strain gage load cell", only for digital machines. Technical details: see pag. 240

- C097-05** CLASS 1, starting from 1% of the full range. With a special calibration procedure it is possible to grant Class 1 practically on the full range of the compression machine. Applicable only on digital machines.

C100

SPLITTING TENSILE test device for cylinders. EN 12390-6 / ASTM C496 Technical details and other models: see pag. 241



C100

C103

SPLITTING TENSILE test device for self blocking pavers and cubes. EN 1338, 12390-6 Technical details: see pag. 241

AS AN ALTERNATIVE:

- C103-01** SPLITTING TENSILE test device for self blocking pavers and cubes having max. dimensions 300x500mm, directly fixed on the large compression platens. EN 1338, 12390-6 Technical details: see pag. 241



C103

C109-12

SOFTWARE for splitting tensile tests with digital machines. Technical details: see pag. 14



C103-01

C106

FLEXURAL TEST DEVICE for concrete beams. EN 12390-5 / ASTM C78, C293 / AASHTO T97 / BS 1881:118 / NF P18-407 / UNI 6133 Technical details: see pag. 242

C109-11

SOFTWARE for flexural tests on concrete beams with digital machines. Technical details: see pag. 14



C106

E170

COMPRESSION DEVICE to test cement specimens 40,1 x 40 mm. EN 196 / ASTM C349 Technical details and other models: see pag. 242

C126

BENCH to hold the compression machine. Technical details: see pag. 244



COMPRESSION TESTING MACHINE 2000 kN CAPACITY

To test blocks max. 500x300 mm, cubes up to 300 mm side and cylinders up to dia. 160x320 mm

Cyber-Plus or Servo-Plus Evolution Touch Screen Digital System

STANDARDS: EN 772-1 / ASTM C39, E447 / AASHTO T22 / UNI 6686 part 1 and 2 / NF P18-411 / BS 1610, 6073
UNE 83304

TECHNICAL SPECIFICATIONS:

- Max. vertical daylight: 336 mm
- Compression platens 510x320x55 mm
- Hydraulic device to stop the piston's stroke at its max excursion to avoid pumping the piston out of the cylinder
- Calibration accuracy: Grade 1.0
- Max. ram travel 55 mm approx.
- Power supply: 230V 1 ph 50 Hz 750 W
- Dimensions: 870x600x1400 mm
- Weight: 850÷900 kg



C078N + C127N
+ C105 + C111-08
+ C121-08



C077N + C127N + C105 + C111-08 + C121-08



C078N + C104-04 + C105 + C111-08 + C121-01 + C127N

ACCESSORIES:

C104-04

CONSOLE HOUSING THE SERVO-PLUS EVOLUTION

The pump assembly and the digital system are encased to enhance the design and look of the machine.

C104-05

ONLINE REMOTE ASSISTANCE PACKAGE

The machine features a connection to Internet through which Matest Customer Service provides real time support to analyze the problem, to find possible solution, and to carry out a proper test execution.

COMPRESSION 2000 kN capacity

LOAD MEASURING SYSTEM

Model	Motorized	Cyber-Plus Evolution mod. C109N (pag. 158)	Servo-Plus Evolution mod. C104N (pag. 158)
C077 N	•	•	
C078 N	•		•



ACCESSORIES FOR 2000 kN BLOCKS MACHINES:

C111-31 DISTANCE PIECE, 20 mm high for cylinders Ø 150x300 mm

C111-04 DISTANCE PIECE, 126 mm high for cubes 200 mm side

C111-05 DISTANCE PIECES, 126+50 mm high for cubes 200 and 150 mm side

C111-06 DISTANCE PIECES 126+50+50 mm high for cubes 200, 150 and 100 mm side

C111-22 DISTANCE PIECE 50 mm high

Note: The cylinders Ø 160x320 mm do not require any distance piece.

C111-50

DISTANCE PIECE

It eliminates the heavy procedure to lift the lower rectangular platen and to add distance pieces.

Technical details: see pag. 247

AS AN ALTERNATIVE:

C112-05

KIT of 4 HANDLES to lift the lower platen, making the positioning of distance pieces easier. Technical details: see pag. 247

AS AN ALTERNATIVE:

C105 CENTRAL SCREW, to get easier the adjustment between the big sized compression platens. Technical details: see pag. 240

C111-27 SLOTTED DISTANCE PIECE, 20 mm high, for central screw

C111-23 SLOTTED DISTANCE PIECE, 50 mm high for central screw

C111-28 SLOTTED DISTANCE PIECE, 76 mm high for central screw

C111-08 SLOTTED DISTANCE PIECE, 126 mm high for central screw

C127N GRAPHIC PRINTER on thermo-paper on board

C127-11 THERMO-PAPER roll for printer (pack of 10 rolls)

C109-10N SOFTWARE for compression tests with Cyber-Plus Evolution machine. See pag. 14

C123N SOFTWARE "servonet" for remote control through PC of Servo-Plus Evolution machine. See pag. 14

C121-01 SAFETY GUARDS, polycarbonate, with hinges and lock, to CE Directive. See pag. 244

C121-51 STOP SWITCH on safety guard. See pag. 244

C107-10 CAPPING RETAINERS (set of two) for cylinders 150 mm and 6"

C107-20 NEOPRENE PADS (set of two) for cylinders Ø150 mm 60 shore A

C110-30

UPPER COMPRESSION PLATEN+SPHERICAL SEAT, to fix on the testing machine in replacement of the standard platen+seat, to obtain an increased vertical clearance of the testing chamber and to meet the ASTM C39 and AASHTO T22 Specifications.

Platen dimensions: dia. 165 x 30 mm

Weight : 10 kg approx.

Technical details: see pag. 243



C111-50

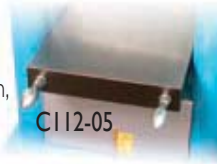

C112-05



C107-10



C110-30

C115-01

TWO WAY HYDRAULIC VALVE, connected to the motorized pumping unit of the machine to activate a second frame. Technical details: see pag. 245



C097-01

C097-01 DUAL LOW CAPACITY DIGITAL RANGE, complete with "appropriate pressure transducer". Recommended range 0-250kN. Technical details: see pag. 240

AS AN ALTERNATIVE:

C097-02 DUAL LOW CAPACITY DIGITAL RANGE 0-300kN, complete with "strain gage load cell". Technical details: see pag. 240

C097-05 CLASS 1, starting from 1% of the full range. With a special calibration procedure it is possible to grant Class 1 practically on the full range of the compression machine.

C100

SPLITTING TENSILE test device for cylinders. EN 12390-6 / ASTM C496 Technical details and other models: see pag. 241



C100

C103

SPLITTING TENSILE test device for self blocking pavers and cubes. EN 1338, 12390-6 Technical details: see pag. 241

AS AN ALTERNATIVE:

C103-01 SPLITTING TENSILE test device for self blocking pavers and cubes having max. dimensions 300x500mm, directly fixed on the large compression platens. EN 1338, 12390-6 Technical details: see pag. 241



C103

C109-12N

SOFTWARE for splitting tensile tests. Technical details: see pag. 14



C103-01

C106

FLEXURAL TEST DEVICE for concrete beams. EN 12390-5 / ASTM C78, C293 / AASHTO T97 BS 1881:118 / NF P18-407 / UNI 6133 Technical details: see pag. 242

C109-11N

SOFTWARE for flexural tests on concrete beams. Technical details: see pag. 14



C106

E170 COMPRESSION DEVICE to test cement specimens 40,1 x 40 mm. EN 196 / ASTM C349 Technical details and other models: see pag. 242

C126 BENCH to hold the compression machine. Technical details: see pag. 244



COMPRESSION TESTING MACHINE 3000 kN CAPACITY To test cubes up to 200 mm side and cylinders up to dia. 160x320 mm

STANDARDS: ASTM C39 / AASHTO T22 / UNI 6686 part 1 and 2 / NF P18-411 / BS 1610 / UNE 83304

TECHNICAL SPECIFICATIONS:

- Max. vertical daylight: 336 mm
- Compression platens dia. 287 mm
- Gauges dia. 250 mm with specific resistance scales for cubes 150 mm and cylinders dia. 150 and 160 mm
- Gauges divisions: 3000 kN div. 10 kN
600 kN div. 2 kN
- Hydraulic device to stop the piston's stroke at its max excursion to avoid pumping the piston out of the cylinder.
- Calibration accuracy: Grade 1.0
- Max. ram travel 55 mm approx.
- Power supply (motorized models): 230 V 1 ph 50 Hz 750 W
- Dimensions: 860x470x1450 mm
- Weight: 1050±1120 kg

section C



188



C070D + C127N + C111-05



C071A + C127N + C111-05



C068 + C111-05 + C121-07

COMPRESSION 3000 kN capacity

Model	Hand Operated	Motorized	LOAD MEASURING SYSTEM			
			1 Gauge	2 Gauge	Digitec mod. C108N (pag. 155)	Autotec mod. C098N (pag. 155)
C066	•		•			
C067	•			•		
C068		•	•			
C069		•		•		
C070 D		•			•	
C071 A		•				•

MATEST

ACCESSORIES FOR 3000 kN MACHINES:

C111-31 DISTANCE PIECE, 20 mm high for cylinders Ø 150x300 mm

C111-04 DISTANCE PIECE, 126 mm high for cubes 200 mm side

C111-05 DISTANCE PIECES, 126+50 mm high for cubes 200, 150 mm side

C111-06 DISTANCE PIECES, 126+50+50 mm high for cubes 200, 150 and 100 mm side

C111-07 DISTANCE PIECES, 50+50 mm high for cylinders Ø 110x220 mm

C111-07 + C111-31

DISTANCE PIECES, high 50+50+20 mm for cylinders Ø 100x200 mm

C111-22 DISTANCE PIECE 50 mm high

C110-20 LOWER COMPRESSION PLATEN, hardened over 55 HRC, Ø 165x50 mm to test cubes 100 mm side (as an alternative to the distance piece 50 mm high)

Note: Cylinders having Ø 160 x 320 mm do not require any distance piece.

C112-10 UPPER+LOWER LARGE COMPRESSION PLATENS 245x510x55 mm complete with SEAT BALL to test "also" blocks.

C127N GRAPHIC PRINTER on thermo-paper on board for digital models

C127-11 THERMO-PAPER roll for printer (pack of 10 rolls)

C109-10 SOFTWARE for compression tests with Digitec machine. See pag. 14

C123 SOFTWARE "servonet" for remote control through PC of Autotec machine. See pag. 14

C119-05 FRAGMENT GUARDS, to CE Directive. See pag. 244

C121-07 SAFETY GUARDS, polycarbonate, with hinges and lock, to CE Directive. See pag. 244

C121-51 STOP SWITCH on safety guard. See pag. 244

C107-10 CAPPING RETAINERS (set of two) for cylinders 150mm and 6"

C107-12 CAPPING RETAINERS (set of two) for cylinders Ø 160mm

C107-20 NEOPRENE PADS (set of two) for cylinders Ø 150mm 60 shore A

C107-25 NEOPRENE PADS (set of two) for cylinders Ø 160mm 60 shore A

C110-30

UPPER COMPRESSION PLATEN + SPHERICAL SEAT, to fix on the testing machine in replacement of the standard platen+seat, to obtain an increased vertical clearance of the testing chamber and to meet the ASTM C39 and AASHTO T22 Specifications.

Platen dimensions: dia. 165 x 30 mm

Weight: 10 kg approx.

Technical details: see pag. 243

C115-01

TWO WAY HYDRAULIC VALVE, connected to the motorized pumping unit of the machine to activate a second frame.

Technical details: see pag. 245



C110-20



C107-10



C110-30

C097-01 DUAL LOW CAPACITY DIGITAL RANGE, complete with "appropriate pressure transducer", only for digital machines. Recommended range 0-250kN. Technical details: see pag. 240

AS AN ALTERNATIVE:

C097-02 DUAL LOW CAPACITY DIGITAL RANGE 0-300kN, complete with "strain gage load cell", only for digital machines. Technical details: see pag. 240

C097-05 CLASS 1, starting from 1% of the full range. With a special calibration procedure it is possible to grant Class 1 practically on the full range of the compression machine. Applicable only on digital machines.

C107-01

AUTO-CENTERING DEVICE for cubes 100 and 150 mm side and cylinders Ø 100 and 150 mm.

Technical details: see pag. 243

C100

SPLITTING TENSILE test device for cylinders. EN 12390-6 / ASTM C496

Technical details and other models: see pag. 241



C100

C103

SPLITTING TENSILE test device for self blocking pavers and cubes. EN 1338, 12390-6.

Technical details: see pag. 241



C103

C109-12

SOFTWARE for splitting tensile tests with digital machines.

Technical details: see pag. 14

C106

FLEXURAL TEST DEVICE for concrete beams. EN 12390-5 / ASTM C78, C293 / AASHTO T97 / BS 1881:118 / NF P18-407 / UNI 6133

Technical details: see pag. 242



C106

C109-11

SOFTWARE for flexural tests on concrete beams with digital machines.

Technical details: see pag. 14

E170

COMPRESSION DEVICE to test cement specimens 40,1 x 40 mm. EN 196 / ASTM C349. Technical details and other models: see pag. 242



E170

C126

BENCH to hold the compression machine.

Technical details: see pag. 244



C115-01



C097-02



COMPRESSION TESTING MACHINE 3000 kN CAPACITY
To test cubes up to 200 mm side and cylinders up to dia. 160x320 mm

Cyber-Plus or Servo-Plus Evolution Touch Screen Digital System

STANDARDS: ASTM C39 / AASHTO T22 / UNI 6686 part 1 and 2 / NF P18-411 / BS 1610 / UNE 83304



TECHNICAL SPECIFICATIONS:

- Max. vertical daylight: 336 mm
- Compression platens dia. 287 mm
- Hydraulic device to stop the piston's stroke at its max excursion to avoid pumping the piston out of the cylinder.
- Calibration accuracy: Grade 1.0
- Max. ram travel 55 mm approx.
- Power supply: 230V 1 ph 50 Hz 750 W
- Dimensions: 860x470x1450 mm
- Weight: 1050±1120 kg

section C



190



C071N + C127N + C111-05



C070N + C127N + C111-05 + C121-07



C104-04

ACCESSORIES:

C104-04

CONSOLE HOUSING THE SERVO-PLUS EVOLUTION

The pump assembly and the digital system are encased to enhance the design and look of the machine.

C104-05

ONLINE REMOTE ASSISTANCE PACKAGE

The machine features a connection to Internet through which Matest Customer Service provides real time support to analyze the problem, to find possible solution, and to carry out a proper test execution.

COMPRESSION 3000 kN capacity

LOAD MEASURING SYSTEM

Model	Motorized	Cyber-Plus Evolution mod. C109N (pag. 158)	Servo-Plus Evolution mod. C104N (pag. 158)
C070 N	•	•	
C071 N	•		•

MATEST

ACCESSORIES FOR 3000 kN MACHINES:

- C111-31** DISTANCE PIECE, 20 mm high for cylinders Ø 150x300 mm
- C111-04** DISTANCE PIECE, 126 mm high for cubes 200 mm side
- C111-05** DISTANCE PIECES, 126+50 mm high for cubes 200, 150 mm side
- C111-06** DISTANCE PIECES, 126+50+50 mm high for cubes 200, 150 and 100 mm side
- C111-07** DISTANCE PIECES, 50+50 mm high for cylinders Ø 110x220 mm
- C111-07 + C111-31** DISTANCE PIECES, high 50+50+20 mm for cylinders Ø 100x200 mm

C111-22 DISTANCE PIECE
50 mm high



C110-20

C110-20 LOWER COMPRESSION PLATEN, hardened over 55 HRC, Ø 165x50 mm to test cubes 100 mm side (as an alternative to the distance piece 50 mm high)

Note: Cylinders having Ø 160 x 320 mm do not require any distance piece.

C112-10 UPPER+LOWER LARGE COMPRESSION PLATENS 245x510x55 mm complete with SEAT BALL to test "also" blocks.

C127N GRAPHIC PRINTER on thermo-paper on board

C127-11 THERMO-PAPER roll for printer (pack of 10 rolls)

C109-10N SOFTWARE for compression tests with Cyber-Plus Evolution machine. See pag. 14

C123N SOFTWARE "servonet" for remote control through PC of Servo-Plus Evolution machine. See pag. 14

C119-05 FRAGMENT GUARDS, to CE Directive. See pag. 244

C121-07 SAFETY GUARDS, polycarbonate, with hinges and lock, to CE Directive. See pag. 244

C121-51 STOP SWITCH on safety guard. See pag. 244

C107-10 CAPPING RETAINERS (set of two) for cylinders 150mm and 6"

C107-12 CAPPING RETAINERS (set of two) for cylinders Ø 160mm

C107-20 NEOPRENE PADS (set of two) for cylinders Ø 150mm 60 shore A

C107-25 NEOPRENE PADS (set of two) for cylinders Ø 160mm 60 shore A



C107-10

C110-30 UPPER COMPRESSION PLATEN + SPHERICAL SEAT, to fix on the testing machine in replacement of the standard platen+seat, to obtain an increased vertical clearance of the testing chamber and to

meet the ASTM C39 and AASHTO T22 Specifications.

Platen dimensions: dia. 165 x 30 mm
Weight: 10 kg approx.

Technical details: see pag. 243



C110-30



C115-01

C115-01

TWO WAY HYDRAULIC VALVE, connected to the motorized pumping unit of the machine to activate a second frame. Technical details: see pag. 245

C097-01 DUAL LOW CAPACITY DIGITAL RANGE, complete with "appropriate pressure transducer". Recommended range 0-250kN. Technical details: see pag. 240

AS AN ALTERNATIVE:

C097-02 DUAL LOW CAPACITY DIGITAL RANGE 0-300kN, complete with "strain gage load cell". Technical details: see pag. 240

C097-05 CLASS 1, starting from 1% of the full range. With a special calibration procedure it is possible to grant Class 1 practically on the full range of the compression machine.

C107-01

AUTO-CENTERING DEVICE for cubes 100 and 150 mm side and cylinders Ø 100 and 150 mm. Technical details: see pag. 243

C100

SPLITTING TENSILE test device for cylinders. EN 12390-6 / ASTM C496
Technical details and other models: see pag. 241



C100

C103

SPLITTING TENSILE test device for self blocking pavers and cubes. EN 1338, 12390-6. Technical details: see pag. 241



C103

C109-12N

SOFTWARE for splitting tensile tests. Technical details: see pag. 14

C106

FLEXURAL TEST DEVICE for concrete beams. EN 12390-5 / ASTM C78, C293 / AASHTO T97 / BS 1881:118 / NF P18-407 / UNI 6133
Technical details: see pag. 242



C106

C109-11N

SOFTWARE for flexural tests on concrete beams. Technical details: see pag. 14

E170

COMPRESSION DEVICE to test cement specimens 40,1 x 40 mm. EN 196 / ASTM C349. Technical details and other models: see pag. 242

C126

BENCH to hold the compression machine. Technical details: see pag. 244



C097-01



C097-02



COMPRESSION TESTING MACHINE 3000 kN CAPACITY

To test blocks max. 500x300 mm, cubes up to 300 mm side and cylinders up to dia. 160x320 mm

STANDARDS: EN 772-1 / ASTM C39, E447 / AASHTO T22 / UNI 6686 part 1 and 2 / NF P18-411 / BS 1610, 6073 / UNE 83304

TECHNICAL SPECIFICATIONS:

- Max. vertical daylight between platens: 336 mm
- Compression platens: 510 x 320xh 55 mm
- Gauges dia. 250 mm with specific resistance scales for cubes 150 mm and cylinders dia. 150 and 160 mm
- Gauges divisions: 3000 kN div. 10 kN - 600 kN div. 2 kN
- Hydraulic device to stop the piston's stroke at its max excursion to avoid pumping the piston out of the cylinder
- Calibration accuracy: Grade 1.0
- Max. ram travel 55 mm approx.
- Power supply (motor models): 230V 1 ph 50 Hz 750 W
- Dimensions: 900x600x1500 mm
- Weight : 1150 ÷ 1220 kg

section C



C079-05D + C127N + C111-22



C079-06A + C127N + C111-22



C079-04 + C111-22

COMPRESSION 3000 kN capacity

Model	Hand Operated	Motorized	LOAD MEASURING SYSTEM			
			1 Gauge	2 Gauge	Digitec mod. C108N (pag. 155)	Autotec mod. C098N (pag. 155)
C079-01	•		•			
C079-02	•			•		
C079-03		•	•			
C079-04		•		•		
C079-05 D		•			•	
C079-06 A		•				•



ACCESSORIES FOR 3000 kN BLOCKS MACHINES:

CI11-31 DISTANCE PIECE, 20 mm high for cylinders Ø 150x300 mm

CI11-04 DISTANCE PIECE, 126 mm high for cubes 200 mm side

CI11-05 DISTANCE PIECES, 126+50 mm high for cubes 200 and 150 mm side

CI11-06 DISTANCE PIECES 126+50+50 mm high for cubes 200, 150 and 100 mm side

CI11-22 DISTANCE PIECE 50 mm high

Note: The cylinders dia. 160x320 mm do not require any distance piece.

CI11-50

DISTANCE PIECE

It eliminates the heavy procedure to lift the lower rectangular platen and to add distance pieces.

Technical details: see pag. 247

AS AN ALTERNATIVE:

CI12-05

KIT of 4 HANDLES to lift the lower platen, making the positioning of distance pieces easier. Technical details: see pag. 247

AS AN ALTERNATIVE:

CI05 CENTRAL SCREW, to get easier the adjustment between the big sized compression platens. Technical details: see pag. 240

CI11-27 SLOTTED DISTANCE PIECE, 20 mm high, for central screw

CI11-23 SLOTTED DISTANCE PIECE, 50 mm high for central screw

CI11-28 SLOTTED DISTANCE PIECE, 76 mm high for central screw

CI11-08 SLOTTED DISTANCE PIECE, 126 mm high for central screw

CI27N GRAPHIC PRINTER on thermo-paper on board for digital models

CI27-11 THERMO-PAPER roll for printer (pack of 10 rolls)

CI09-10 SOFTWARE for compression tests with Digitec machine. See pag. 14

CI23 SOFTWARE "servonet" for remote control through PC of Autotec machine. See pag. 14

CI21-08 SAFETY GUARDS, polycarbonate, with hinges and lock, to CE Directive. See pag. 244

CI21-51 STOP SWITCH on safety guard. See pag. 244

CI07-10 CAPPING RETAINERS (set of two) for cylinders 150mm and 6"

CI07-20 NEOPRENE PADS (set of two) for cylinders Ø150mm 60 shore A

CI10-30

UPPER COMPRESSION PLATEN+SPHERICAL SEAT, to fix on the testing machine in replacement of the standard platen+seat, to obtain an increased vertical clearance of the testing chamber and to meet the ASTM C39 and AASHTO T22 Specifications.

Platen dimensions: dia. 165 x 30 mm

Weight : 10 kg approx.

Technical details: see pag. 243



CI11-50

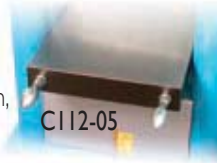

CI12-05



CI07-10



CI10-30

CI15-01

TWO WAY HYDRAULIC VALVE, connected to the motorized pumping unit of the machine to activate a second frame. Technical details: see pag. 245



CI15-01

CO97-01 DUAL LOW CAPACITY DIGITAL RANGE, complete with "appropriate pressure transducer", only for digital machines. Recommended range 0-250kN. Technical details: see pag. 240

AS AN ALTERNATIVE:

CO97-02 DUAL LOW CAPACITY DIGITAL RANGE 0-300kN, complete with "strain gage load cell", only for digital machines. Technical details: see pag. 240

CO97-05 CLASS 1, starting from 1% of the full range. With a special calibration procedure it is possible to grant Class 1 practically on the full range of the compression machine. Applicable only on digital machines.

CI00

SPLITTING TENSILE test device for cylinders. EN 12390-6 / ASTM C496. Technical details and other models: see pag. 241



CI00

CI03

SPLITTING TENSILE test device for self blocking pavers and cubes. EN 1338, 12390-6

Technical details: see pag. 241

AS AN ALTERNATIVE:

CI03-01

SPLITTING TENSILE test device for self blocking pavers and cubes having max. dimensions 300x500 mm, directly fixed on the large compression platens. EN 1338, 12390-6

Technical details: see pag. 241



CI03

CI09-12

SOFTWARE for splitting tensile tests with digital machines.

Technical details see pag. 14



CI03-01

CI06

FLEXURAL TEST DEVICE for concrete beams. EN 12390-5 / ASTM C78, C293 / AASHTO T97 / BS 1881:118 / NF P18-407 / UNI 6133

Technical details: see pag. 242



CI06

CI09-11

SOFTWARE for flexural tests on concrete beams with digital machines. Technical details: see pag. 14

E170 COMPRESSION DEVICE to test cement specimens 40,1 x 40 mm. EN 196 / ASTM C349. Technical details and other models: see pag. 242

CI26 BENCH to hold the compression machine. See pag. 244



COMPRESSION TESTING MACHINE 3000 kN CAPACITY

To test blocks max. 500x300 mm, cubes up to 300 mm side and cylinders up to dia. 160x320 mm

Cyber-Plus or Servo-Plus Evolution Touch Screen Digital System

STANDARDS: EN 772-1 / ASTM C39, E447 / AASHTO T22 / UNI 6686 part 1 and 2 / NF P18-411
BS 1610, 6073 / UNE 83304

TECHNICAL SPECIFICATIONS:

- Max. vertical daylight between platens: 336 mm
- Compression platens: 510 x 320xh 55 mm
- Hydraulic device to stop the piston's stroke at its max excursion to avoid pumping the piston out of the cylinder
- Calibration accuracy: Grade 1.0
- Max. ram travel 55 mm approx.
- Power supply: 230V 1 ph 50 Hz 750 W
- Dimensions: 900x600x1500 mm
- Weight : 1150÷1220 kg



section C



194



C079-06N + C104-04 + C127N + C111-22



C079-06N + C127N + C111-22



C079-05N + C127N + C111-22

ACCESSORIES:

C104-04

CONSOLE HOUSING THE SERVO-PLUS EVOLUTION

The pump assembly and the digital system are encased to enhance the design and look of the machine.

C104-05

ONLINE REMOTE ASSISTANCE PACKAGE

The machine features a connection to Internet through which Matest Customer Service provides real time support to analyze the problem, to find possible solution, and to carry out a proper test execution.

COMPRESSION 3000 kN capacity

LOAD MEASURING SYSTEM

Model	Motorized	Cyber-Plus Evolution mod. C109N (pag. 158)	Servo-Plus Evolution mod. C104N (pag. 158)
C079-05 N	•	•	
C079-06 N	•		•

MATEST

ACCESSORIES FOR 3000 kN BLOCKS MACHINES:

- C111-31** DISTANCE PIECE, 20 mm high for cylinders Ø 150x300 mm
- C111-04** DISTANCE PIECE, 126 mm high for cubes 200 mm side
- C111-05** DISTANCE PIECES, 126+50 mm high for cubes 200 and 150 mm side
- C111-06** DISTANCE PIECES 126+50+50 mm high for cubes 200, 150 and 100 mm side
- C111-22** DISTANCE PIECE 50 mm high

Note: The cylinders dia. 160x320 mm do not require any distance piece.

C111-50

DISTANCE PIECE

It eliminates the heavy procedure to lift the lower rectangular platen and to add distance pieces.

Technical details: see pag. 247



C111-50

AS AN ALTERNATIVE:

C112-05

KIT of 4 HANDLES to lift the lower platen, making the positioning of distance pieces easier. Technical details: see pag. 247

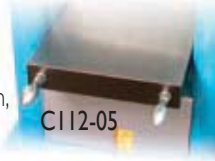

C112-05

AS AN ALTERNATIVE:

- C105** CENTRAL SCREW, to get easier the adjustment between the big sized compression platens. Technical details: see pag. 240

- C111-27** SLOTTED DISTANCE PIECE, 20 mm high, for central screw
- C111-23** SLOTTED DISTANCE PIECE, 50 mm high for central screw
- C111-28** SLOTTED DISTANCE PIECE, 76 mm high for central screw
- C111-08** SLOTTED DISTANCE PIECE, 126 mm high for central screw

C127N GRAPHIC PRINTER on thermo-paper on board

C127-11 THERMO-PAPER roll for printer (pack of 10 rolls)

C109-10N SOFTWARE for compression tests with Cyber-Plus Evolution machine. See pag. 14

C123N SOFTWARE "servonet" for remote control through PC of Servo-Plus Evolution machine. See pag. 14

C121-08 SAFETY GUARDS, polycarbonate, with hinges and lock, to CE Directive. See pag. 244

C121-51 STOP SWITCH on safety guard. See pag. 244

C107-10 CAPPING RETAINERS (set of two) for cylinders 150mm and 6"

C107-20 NEOPRENE PADS (set of two) for cylinders Ø150mm 60 shore A



C107-10

C110-30

UPPER COMPRESSION PLATEN+SPHERICAL SEAT, to fix on the testing machine in replacement of the standard platen+seat, to obtain an increased vertical clearance of the testing chamber and to meet the ASTM C39

and AASHTO T22 Specifications. Platen dimensions: dia. 165 x 30 mm Weight : 10 kg approx.

Technical details: see pag. 243



C110-30

C115-01

TWO WAY HYDRAULIC VALVE, connected to the motorized pumping unit of the machine to activate a second frame. Technical details: see pag. 245

C097-01 DUAL LOW CAPACITY DIGITAL RANGE, complete with "appropriate pressure transducer". Recommended range 0-250kN. Technical details: see pag. 240

AS AN ALTERNATIVE:



C097-01

C097-02

DUAL LOW CAPACITY DIGITAL RANGE 0-300kN, complete with "strain gage load cell". Technical details: see pag. 240

C097-05 CLASS 1, starting from 1% of the full range. With a special calibration procedure it is possible to grant Class 1 practically on the full range of the compression machine.

C100

SPLITTING TENSILE test device for cylinders. EN 12390-6 / ASTM C496 Technical details and other models: see pag. 241



C100

C103

SPLITTING TENSILE test device for self blocking pavers and cubes. EN 1338, 12390-6 Technical details: see pag. 241

AS AN ALTERNATIVE:



C103

C103-01

SPLITTING TENSILE test device for self blocking pavers and cubes having max. dimensions 300x500 mm, directly fixed on the large compression platens. EN 1338, 12390-6 Technical details: see pag. 241

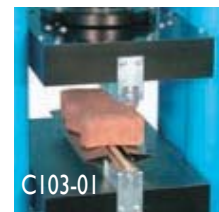

C103-01

C109-12N

SOFTWARE for splitting tensile tests. Technical details see pag. 14

C106

FLEXURAL TEST DEVICE for concrete beams. EN 12390-5 / ASTM C78, C293 / AASHTO T97 / BS 1881:118 / NF P18-407 / UNI 6133 Technical details: see pag. 242



C106

C109-11N

SOFTWARE for flexural tests on concrete beams. Technical details: see pag. 14

E170 COMPRESSION DEVICE to test cement specimens 40,1 x 40 mm. EN 196 / ASTM C349 Technical details and other models: see pag. 242

C126 BENCH to hold the compression machine. See pag. 244



COMPRESSION TESTING MACHINE 5000 kN CAPACITY
To test cubes up to 300 mm side and cylinders up to dia. 250x500 mm

Cyber-Plus or Servo-Plus Evolution Touch Screen Digital System

STANDARDS: BS 1610 / UNI 6686 part 1 and 2 / NF P18-411 / ASTM C39 / AASHTO T22 / UNE 83304



section C

TECHNICAL SPECIFICATIONS:

- Max. vertical daylight: 530 mm
- Compression platens 310x310 mm
- Calibration accuracy: Grade 1.0
- Max. ram travel 60 mm approx.
- Hydraulic device to stop the piston's stroke at its max excursion to avoid pumping the piston out of the cylinder.
- Power supply: 230V 1 ph 50 Hz 750 W
- Dimensions: 1200x900x1900 mm
- Weight: 2800±2900 kg



196



C086-02N + C127N + H009-01



C086-03N + C127N + C086-10

ACCESSORY:

C104-05

ONLINE REMOTE ASSISTANCE PACKAGE

The machine features a connection to Internet through which Matest Customer Service provides real time support to analyze the problem, to find possible solution, and to carry out a proper test execution.

COMPRESSION 5000 kN capacity

LOAD MEASURING SYSTEM

Model	Motorized	Cyber-Plus Evolution mod. C109N (pag. 158)	Servo-Plus Evolution mod. C104N (pag. 158)
C086-02 N	•	•	
C086-03 N	•		•

ACCESSORIES FOR 5000 kN MACHINES:

C086-10 DISTANCE PIECE, 50 mm high

C086-11 DISTANCE PIECE, 25 mm high

Note: Vertical daylight of the compression platens is 530 mm.

The operator will have to buy the needed distance pieces to reduce the daylight between the compression platens to get the correct daylight of the specimen under test plus approx.

10 to 15 mm

C112-11

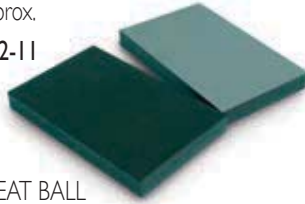

C112-11

UPPER+LOWER LARGE COMPRESSION PLATENS+SEAT BALL

310x510x55 mm to test "also" blocks. It is necessary to have also the sliding rail carriage mod. C117

C117

SLIDING RAIL CARRIAGE, for an easy removal of the large block upper platen

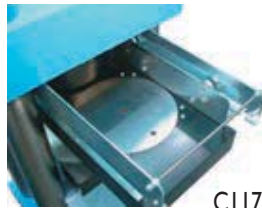

C117

C127N GRAPHIC PRINTER on thermo-paper on board

C127-11 THERMO-PAPER roll for printer (pack of 10 rolls)

C109-10N SOFTWARE for compression tests with Cyber-Plus Evolution machine. See pag. 14

C123N SOFTWARE "servonet" for remote control through PC of Servo-Plus Evolution machine. See pag. 14

C121-04 SAFETY GUARDS, polycarbonate, with hinges and lock, to CE Directive. See pag. 244

C121-51 STOP SWITCH on safety guard. See pag. 244

C115-01

TWO WAY HYDRAULIC VALVE, connected to the motorized pumping unit of the machine to activate a second frame. Technical details: see pag. 245



C115-01

C097-01

DUAL LOW CAPACITY DIGITAL RANGE, complete with "appropriate pressure transducer". Recommended range 0-250kN. Technical details: see pag. 240

AS AN ALTERNATIVE:

C097-02

DUAL LOW CAPACITY DIGITAL RANGE 0-300kN, complete with "strain gage load cell". Technical details: see pag. 240



C097-01

C097-05

CLASS 1, starting from 1% of the full range.

With a special calibration procedure it is possible to grant Class 1 practically on the full range of the compression machine.

C100

SPLITTING TENSILE test device for cylinders. EN 12390-6 / ASTM C496. Technical details and other models: see pag. 241



C100

C103

SPLITTING TENSILE test device for self blocking pavers and cubes. EN 1338, 12390-6. Technical details: see pag. 241



C103

C109-12N

SOFTWARE for splitting tensile tests with digital machines. Technical details: see pag. 14

C106

FLEXURAL TEST DEVICE for concrete beams. EN 12390-5 / ASTM C78, C293 / AASHTO T97 / BS 1881:118 / NP F18-407 / UNI 6133. Technical details: see pag. 242



C106

C109-11N

SOFTWARE for flexural tests on concrete beams. Technical details: see pag. 14

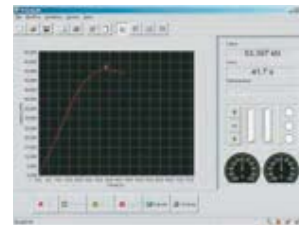

C109-11N Software Flexural

E170

COMPRESSION DEVICE to test cement specimens 40,1 x 40 mm. EN 196 / ASTM C349. Technical details and other models: see pag. 242



E170

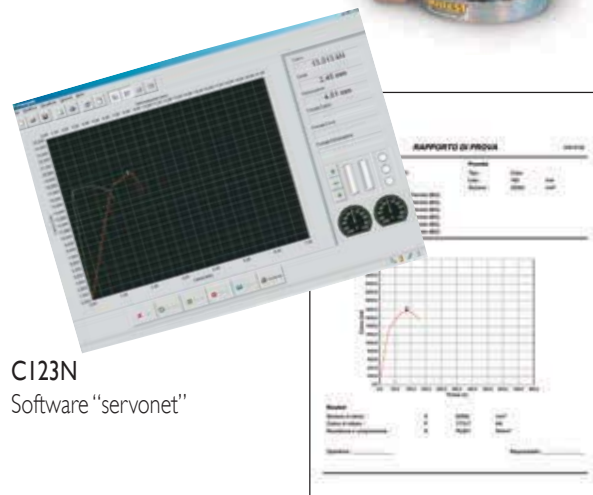

C123N Software "servonet"

C109-10N Software Compression





17/05/2007

REPORT

Data

Date : 17/05/2007
 Request n° : 1705
 Certificate n° : 17052007
 Laboratory : Matest
 Site : Matest
 Temperature : 20 °C

Sp
 Typ
 Wid
 Thic
 Upp
 Low
 Sec

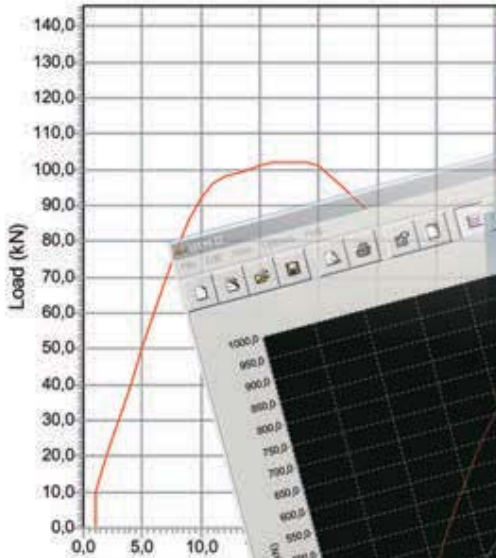

Results

Width :
 Height :
 Distance :
 Maximum load :
 Strength :

12

25 2

COMPRES

Maximum Stress



COMPRESSION TESTING MACHINES “TESTED FOR HIGH STABILITY”, FOUR COLUMNS PRESTRESSED FRAME

The compression machines “tested for high stability” meet the stringent requirements of the:

EN 12390-4 / BS 1881:115 / DIN 51220. / UNI 6686, part 3 / NF P18-411 / UNE 83304 / ASTM C39 / AASHTOT22

The machines are manufactured with specific quality features (processing, tolerances) of frame, piston/cylinder group, spherical seat, compression platens, distance pieces etc., conforming and meeting the high stability verification. (force distribution).

The conformity of the stability is certified with the verification of the self-alignment (foot-meter test) of the machines's components and the restraint on movement of the upper spherical seat/platen, by using a special electric strain load column at 5 measuring points which is connected to its suitable datalogger (technical details: see pag. 251)

An incorrect and not uniform load application to the specimen causes irregular, unsatisfactory and premature failure. The obtained compression resistance can be substantially lower than the effective resistance.

The most important feature of the “high stability frames” is their uniform distribution of the applied load on all the specimen's surface under test. The sample breakage is satisfactory and the strength results are correct, high and true.

- The four columns frame is prestressed on 8 ring nuts and the clamping is obtained and checked by a dynamometric spanner; allowing to get a very high stiffness and stability on all load range and to keep these features in the time.
- The spherical seat, in oil bath with null end float, is studied and manufactured to grant, during the starting phase of the test, an accurate self-alignment without frictions of the upper compression platen to the specimen. By applying the load, the ball seating assembly locks and keeps the position until the specimen's failure.
- Piston and cylinder are coupled with high quality packing set.
- Compression platens are hardened over 55 HRC and rectified.



Available in the capacities: 2000 kN / 2000 kN blocks / 3000 kN / 3000 kN blocks / 4000 kN / 5000 kN

Load measuring system: Bourdon type gauge

“Digitec” or “Cyber-Plus Evolution” graphic display unit

Servo-controlled automatic system “Autotec” or “Servo-Plus Evolution” with optional “elastic modulus” determination.

Described and pictured in the next pages 200 ÷ 221



COMPRESSION TESTING MACHINE 2000 kN CAPACITY "TESTED FOR HIGH STABILITY"

To test cubes up to 200 mm side and cylinders up to dia. 160x320 mm

STANDARDS: EN 12390-4 / BS 1881:115 / UNI 6686 part 3 / DIN 51220, 51302 / ASTM C39 / NF P18-411
AASHTO T22 / UNE 83304

TECHNICAL SPECIFICATIONS:

- Max. vertical daylight: 334,5 mm
- Compression platens dia. 287x60 mm
- Gauges dia. 250 mm with specific resistance scales for cubes 150 mm and cylinders dia. 150 and 160 mm
- Gauges divisions: 2000 kN div. 5 kN - 600 kN div. 2 kN
- Calibration accuracy: Grade 1.0
- Max. ram travel 60 mm approx.
- Hydraulic device to stop the piston's stroke at its max excursion, to avoid pumping the piston out of the cylinder.
- Power supply: 230V 1 ph 50 Hz 750 W
- Dimensions: 690x400x1400 mm
- Weight: 850÷920 kg

section C



200



C089-04A + C127N + C121-06 + C111-13



C089-02D + C127N + C121-06 + C111-13



C089 + C111-24

COMPRESSION 2000 kN High Stability

Model	Motorized	LOAD MEASURING SYSTEM			
		1 Gauge	2 Gauge	Digitec mod. C108N (pag. 155)	Autotec mod. C098N (pag. 155)
C089	•	•			
C089-01	•		•		
C089-02 D	•			•	
C089-04 A	•				•

MATEST

ACCESSORIES FOR 2000 kN MACHINES:

- C111-32** DISTANCE PIECE, 20 mm high for cylinders Ø 150x300 mm
- C111-12** DISTANCE PIECE, 73+50 mm high for cubes 200 mm side
- C111-13** DISTANCE PIECES, 73+50+50 mm high for cubes 200 and 150 mm side
- C111-14** DISTANCE PIECES, 73+50+50+50 mm high for cubes 200, 150 and 100 mm side
- C111-15** DISTANCE PIECES, 50+50 mm high for cylinders Ø 110x220 mm
- C111-24** DISTANCE PIECE 50 mm high
- C111-25** DISTANCE PIECE 73 mm high
- C110-20** LOWER COMPRESSION PLATEN, hardened and rectified, dia. 165x50 mm to test cubes 100 mm (as an alternative to the distance piece 50 mm high)



C110-20

Note: Cylinders having Ø 160 x 320 mm do not require any distance piece.

- C127N** GRAPHIC PRINTER on thermo-paper on board for digital models
- C127-II** THERMO-PAPER roll for printer (pack of 10 rolls)
- C109-10** SOFTWARE for compression tests with Digitec machine. See pag. 14
- C123** SOFTWARE "servonet" for remote control through PC of Autotec machine. See pag. 14

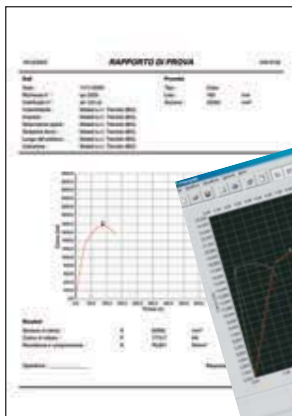

C109-10
Software Compression



C123
Software "servonet"

- C119-04** FRAGMENT GUARDS, to CE Directive. See pag. 244
- C121-06** SAFETY GUARDS, polycarbonate, with hinges and lock, to CE Directive. See pag. 244
- C121-51** STOP SWITCH on safety guard. See pag. 244
- C107-10** CAPPING RETAINERS (set of two) for cylinders Ø 150mm and 6"
- C107-20** NEOPRENE PADS (set of two) for cylinders Ø 150mm 60 shore A



C107-10

- C110-30** UPPER COMPRESSION PLATEN+SPHERICAL SEAT, to fix on the testing machine in replacement of the standard platen+seat, to obtain an increased vertical clearance of the testing chamber and to meet the ASTM C39 and AASHTO T22 Specifications. Platen dimensions: dia. 165 x 30 mm. Weight : 10 kg approx. Technical details: see pag. 243



C110-30

- C115-01** TWO WAY HYDRAULIC VALVE, connected to the motorized pumping unit of the machine to activate a second frame. Technical details: see pag. 245

- C097-01** DUAL LOW CAPACITY DIGITAL RANGE, complete with "appropriate pressure transducer", only for digital machines. Recommended range 0-250kN Technical details: see pag. 240



C097-02

AS AN ALTERNATIVE:

- C097-02** DUAL LOW CAPACITY DIGITAL RANGE 0-300kN, complete with "strain gage load cell", only for digital machines. Technical details: see pag. 240

- C097-05** CLASS 1, starting from 1% of the full range. With a special calibration procedure it is possible to grant Class 1 practically on the full range of the compression machine. Applicable only on digital machines.

- C097-08** OFFICIAL ACCREDIA (Equivalent UKAS, ENAC, DAKKS, SAS, COFRAC etc.) HARDNESS CERTIFICATE of upper and lower compression platens. Minimum hardness: 55 HRC. See pag. 240

- C107-01** AUTO-CENTERING DEVICE for cubes 100 and 150 mm side and cylinders dia. 100 and 150 mm. Technical details: see pag. 243

- C100** SPLITTING TENSILE test device for cylinders. EN 12390-6 / ASTM C496 Technical details and other models: see pag. 241



C100

- C109-12** SOFTWARE for splitting tensile tests with digital machines. Technical details: see pag. 14

- C106** FLEXURAL TEST DEVICE for concrete beams. EN 12390-5 / ASTM C78, C293 / AASHTO T97 / BS 1881:118 / NF P18-407 / UNI 6133. Technical details: see pag. 242

- C109-11** SOFTWARE for flexural tests on concrete beams with digital machines. Technical details: see pag. 14

- E170** COMPRESSION DEVICE to test cement specimens 40,1 x 40 mm. EN 196 / ASTM C349. Technical details and other models: see pag. 242

- C126** BENCH to hold the compression machine. Technical details: see pag. 244



**COMPRESSION TESTING MACHINE 2000 kN CAPACITY
"TESTED FOR HIGH STABILITY"**

To test cubes up to 200 mm side and cylinders up to dia. 160x320 mm

Cyber-Plus or Servo-Plus Evolution Touch Screen Digital System

STANDARDS: EN 12390-4 / BS 1881:115 / UNI 6686, part3 / DIN 51220, 51302 / ASTM C39
NF P18-411 / AASHTOT22 / UNE 83304

TECHNICAL SPECIFICATIONS:

- Max. vertical daylight: 334,5 mm
- Compression platens dia. 287x60 mm
- Calibration accuracy: Grade 1.0
- Max. ram travel 60 mm approx.
- Hydraulic device to stop the piston's stroke at its max excursion, to avoid pumping the piston out of the cylinder.
- Power supply: 230V 1 ph 50 Hz 750 W
- Dimensions: 690x400x1400 mm
- Weight: 850÷920 kg



section C



202



C089-02N + C127N + C111-13

C089-04N + C104-04 + C127N + C111-13 + C121-06

ACCESSORIES:

C104-04

CONSOLE HOUSING THE SERVO-PLUS EVOLUTION

The pump assembly and the digital system are encased to enhance the design and look of the machine.

C104-05

ONLINE REMOTE ASSISTANCE PACKAGE

The machine features a connection to Internet through which Matest Customer Service provides real time support to analyze the problem, to find possible solution, and to carry out a proper test execution.



C089-04N + C127N + C111-13

COMPRESSION 2000 kN High Stability

LOAD MEASURING SYSTEM

Model	Motorized	Cyber-Plus Evolution mod. C109N (pag. 158)	Servo-Plus Evolution mod. C104N (pag. 158)
C089-02 N	•	•	
C089-04 N	•		•

MATEST

ACCESSORIES FOR 2000 kN MACHINES:

- C111-32** DISTANCE PIECE, 20 mm high for cylinders Ø 150x300 mm
- C111-12** DISTANCE PIECE, 73+50 mm high for cubes 200 mm side
- C111-13** DISTANCE PIECES, 73+50+50 mm high for cubes 200 and 150 mm side
- C111-14** DISTANCE PIECES, 73+50+50+50 mm high for cubes 200, 150 and 100 mm side
- C111-15** DISTANCE PIECES, 50+50 mm high for cylinders Ø 110x220 mm
- C111-24** DISTANCE PIECE 50 mm high
- C111-25** DISTANCE PIECE 73 mm high
- C110-20** LOWER COMPRESSION PLATEN, hardened and rectified, dia. 165x50 mm to test cubes 100 mm (as an alternative to the distance piece 50 mm high)



Note: Cylinders having Ø 160 x 320 mm do not require any distance piece.

- C127N** GRAPHIC PRINTER on thermo-paper on board
- C127-11** THERMO-PAPER roll for printer (pack of 10 rolls)
- C109-10N** SOFTWARE for compression tests with Cyber-Plus Evolution machine. See pag. 14
- C123N** SOFTWARE "servonet" for remote control through PC of Servo-Plus Evolution machine. See pag. 14

- C104-10N**
SERVO-STRAIN
Servocontrolled Software, system of:
- Load or Strength
- Displacement
- Strain

This system can be used only with Servo-Plus Evolution machine mod. C089-04N
Technical details see pag. 164

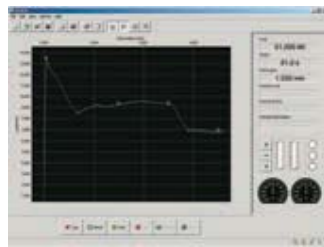

C104-10N

- C125N**
ELASTIC MODULUS determination of the secant compression on concrete. Automatic system with pace rate control also when releasing the load, applicable only to high stability frames with Servo-Plus Evolution. EN 12390-13, UNI 6556, ASTM C469 ISO 1920-10, DIN 1048.
Technical details: see pag. 220

- C119-04** FRAGMENT GUARDS to CE Directive. See pag. 244

- C121-06** SAFETY GUARDS, polycarbonate and aluminium frame, complete with hinges and lock, to CE Directive. See pag. 244



C107-10

- C121-51** STOP SWITCH on safety guard. See pag. 244

- C107-10** CAPPING RETAINERS (set of two) for cylinders Ø 150mm and 6"

- C107-21** NEOPRENE PADS (set of two) for cylinders Ø 150mm 70 shore A

C110-30

UPPER COMPRESSION PLATEN + SPHERICAL SEAT, to fix on the testing machine in replacement of the standard platen+seat, to obtain an increased vertical clearance of the testing chamber and to meet the ASTM C39 and AASHTO T22 Specifications.

Platen dimensions: dia. 165 x 30 mm. Weight : 10 kg approx.
Technical details: see pag. 243



C115-01

TWO WAY HYDRAULIC VALVE, connected to the motorized pumping unit of the machine to activate a second frame.
Technical details: see pag. 245



C097-01

DUAL LOW CAPACITY DIGITAL RANGE, complete with "appropriate pressure transducer". Recommended range 0-250kN
Technical details: see pag. 240

AS AN ALTERNATIVE:



C097-01

C097-02

DUAL LOW CAPACITY DIGITAL RANGE 0-300kN, complete with "strain gage load cell". Technical details: see pag. 240

C097-05

CLASS 1, starting from 1% of the full range. With a special calibration procedure it is possible to grant Class 1 practically on the full range of the compression machine.

C097-08

OFFICIAL ACCREDIA (Equivalent UKAS, ENAC, DAKKS, SAS, COFRAC etc.) HARDNESS CERTIFICATE of upper and lower compression platens. Minimum hardness: 55 HRC. See pag. 240

- C107-01** AUTO-CENTERING DEVICE for cubes 100 and 150 mm side and cylinders Ø 100 and 150 mm
Technical details: see pag. 243

- C100** SPLITTING TENSILE test device for cylinders. EN 12390-6 / ASTM C496
Technical details and other models: see pag. 241

- C109-12N** SOFTWARE for splitting tensile tests.
Technical details: see pag. 14

C106

FLEXURAL TEST DEVICE for concrete beams. EN 12390-5 / ASTM C78, C293 / AASHTO T97 / BS 1881:118 / NF P18-407 / UNI 6133. Technical details: see pag. 242

- C109-11N** SOFTWARE for flexural tests on concrete beams with digital machines. Technical details: see pag. 14

E170

COMPRESSION DEVICE to test cement specimens 40,1 x 40 mm. EN 196 / ASTM C349
Technical details and other models: pag. 242

C126

BENCH to hold the compression machine.
Technical details: pag. 244



E170



COMPRESSION TESTING MACHINE 2000 kN CAPACITY "TESTED FOR HIGH STABILITY"

To test blocks max. 500x300 mm, cubes up to 200 mm side and cylinders up to dia. 160x320 mm

STANDARDS: EN 12390-4, EN 772-1 / BS 1881:1 15, 6073 / UNI 6686 part 3 / DIN 51220, 51302 / NF P18-411 / ASTM C39, E447
AASHTO T22 / UNE 83304

TECHNICAL SPECIFICATIONS:

- Max. vertical daylight to test blocks: 283 mm
- Compression platens for blocks: 510x320x55 mm
- Max. vertical daylight to test cubes and cylinders: 334,5 mm
- Compression platens to test cubes and cylinders: dia. 287x60 mm
- Gauges dia. 250 mm with specific resistance scales for cubes 150 mm and cylinders dia. 150 and 160 mm
- Gauges divisions: 2000 kN div. 10 kN - 600 kN div. 2 kN
- Calibration accuracy: Grade 1.0
- Max. ram travel 60 mm approx.
- Hydraulic device to stop the piston's stroke at its max excursion, to avoid pumping the piston out of the cylinder.
- Power supply: 230V 1 ph 50 Hz 750 W
- Dimensions: 750x520x1500 mm
- Weight: 1000÷1070 kg

section C



204



C089-21D + C127N

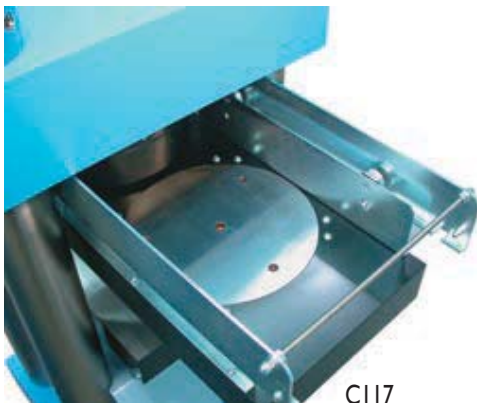

C117



C089-22A + C127N

COMPRESSION 2000 kN High Stability Blocks

Model	Motorized	LOAD MEASURING SYSTEM			
		1 Gauge	2 Gauge	Digitec mod. C108N (pag. 155)	Autotec mod. C098N (pag. 155)
C089 B	•	•			
C089-01 B	•		•		
C089-21 D	•			•	
C089-22 A	•				•

MATTEST

ACCESSORIES FOR 2000 kN BLOCKS MACHINES:

- C111-32** DISTANCE PIECE, 20 mm high for cylinders Ø 150x300 mm
 - C111-12** DISTANCE PIECE, 73+50 mm high for cubes 200 mm side
 - C111-13** DISTANCE PIECES, 73+50+50 mm high for cubes 200 and 150 mm side
 - C111-14** DISTANCE PIECES, 73+50+50+50 mm high for cubes 200, 150 and 100 mm side
 - C111-15** DISTANCE PIECES, 50+50 mm high for cylinders Ø 110x220 mm
 - C111-24** DISTANCE PIECE 50 mm high
 - C111-25** DISTANCE PIECE 73 mm high
- Note: Cylinders having Ø 160 x 320 mm do not require any distance piece.

C111-50

DISTANCE PIECE

It eliminates the heavy procedure to lift the lower rectangular platen and to add distance pieces.

Technical details: see pag. 247



C111-50

AS AN ALTERNATIVE:

C112-05

KIT of 4 HANDLES to lift the lower platen, making the positioning of distance pieces easier. Technical details: see pag. 247



C112-05

C117

SLIDING RAIL CARRIAGE, for an easy removal of the upper block platen, to perform tests on blocks or on standard cubes and cylinders.

C127N GRAPHIC PRINTER on thermo-paper on board for digital models

C127-11 THERMO-PAPER roll for printer (pack of 10 rolls)

C109-10 SOFTWARE for compression tests with Digitec machine. See pag. 14

C123 SOFTWARE "servonet" for remote control through PC of Autotec machine. See pag. 14

C121-10 SAFETY GUARDS, polycarbonate, with hinges and lock, to CE Directive. See pag. 244

C121-51 STOP SWITCH on safety guard. See pag. 244

C115-01

TWO WAY HYDRAULIC VALVE, connected to the motorized pumping unit of the machine to activate a second frame. Technical details: see pag. 245



C115-01

C097-05

CLASS 1, starting from 1% of the full range. With a special calibration procedure it is possible to grant Class 1 practically on the full range of the compression machine. Applicable only on digital machines.

C097-08

OFFICIAL ACCREDITIA (Equivalent UKAS, ENAC, DAKKS, SAS, COFRAC etc.)

HARDNESS CERTIFICATE of upper and lower compression platens. Minimum hardness: 55 HRC. See pag. 240



C097-01

C097-01

DUAL LOW CAPACITY DIGITAL RANGE, complete with "appropriate pressure transducer", only for digital machines. Recommended range 0-250kN. Technical details: see pag. 240

AS AN ALTERNATIVE:

C097-02

DUAL LOW CAPACITY DIGITAL RANGE 0-300kN, complete with "strain gage load cell", only for digital machines. Technical details: see pag. 240

C100 SPLITTING TENSILE test device for cylinders. EN 12390-6 / ASTM C496
Technical details and other models: see pag. 241

C103

SPLITTING TENSILE test device for self blocking pavers and cubes. EN 1338, 12390-6

Technical details: see pag. 241

AS AN ALTERNATIVE:

C103-01

SPLITTING TENSILE test device for self blocking pavers and cubes max. dimensions 300 x 500 mm. EN 1338, 12390-6. Technical details: see pag. 241

C109-12 SOFTWARE for splitting tensile tests with digital machines. Technical details: see pag. 14

C106

FLEXURAL TEST DEVICE for concrete beams. EN 12390-5 / ASTM C78, C293 / AASHTO T97 / BS 1881:118 / NF P18-407 / UNI 613
Technical details: see pag. 242

C109-11

SOFTWARE for flexural tests on concrete beams with digital machines. Technical details: see pag. 14



C106

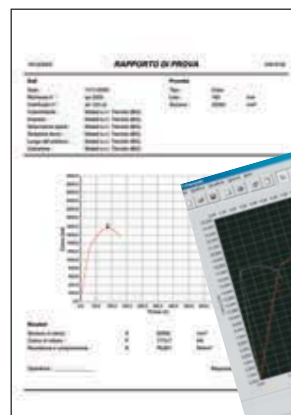

C109-10
Software Compression

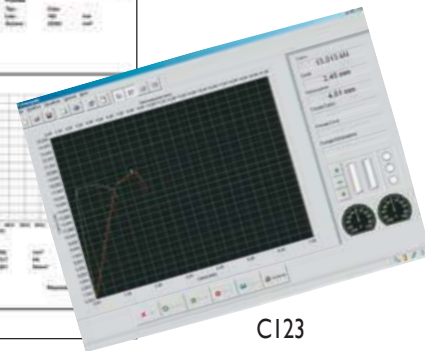

C123
Software "servonet"

E170

COMPRESSION DEVICE to test cement specimens 40,1 x 40 mm. EN 196 / ASTM C349
Technical details and other models: see pag. 242

C126

BENCH to hold the compression machine. Technical details: see pag. 244



E170



COMPRESSION TESTING MACHINE 2000 kN CAPACITY "TESTED FOR HIGH STABILITY"

To test blocks max. 500x300 mm, cubes up to 200 mm side and cylinders up to dia. 160x320 mm

Cyber-Plus or Servo-Plus Evolution Touch Screen Digital System

STANDARDS: EN 12390-4, EN 772-1 / BS 1881:1 15, 6073 / UNI 6686 part 3 / DIN 51220, 51302 / NF P18-411
ASTM C39, E447 / AASHTO T22 / UNE 83304



section C



206

TECHNICAL SPECIFICATIONS:

- Max. vertical daylight to test blocks: 283 mm
- Compression platens for blocks: 510x320x55 mm
- Max. vertical daylight to test cubes and cylinders: 334,5 mm
- Compression platens to test cubes and cylinders: dia. 287x60 mm
- Calibration accuracy: Grade 1.0
- Max. ram travel 60 mm approx.
- Hydraulic device to stop the piston's stroke at its max excursion, to avoid pumping the piston out of the cylinder.
- Power supply: 230V 1 ph 50 Hz 750 W
- Dimensions: 750x520x1500 mm
- Weight: 1000±1070 kg



C089-21N + C127N



C089-22N + C104-04 + C127N



C089-22N + C127N

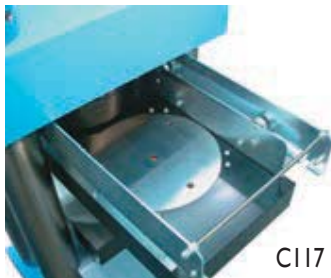

C117

ACCESSORIES:

C104-04

CONSOLE HOUSING THE SERVO-PLUS EVOLUTION

The pump assembly and the digital system are encased to enhance the design and look of the machine.

C104-05

ONLINE REMOTE ASSISTANCE PACKAGE

The machine features a connection to Internet through which Matest Customer Service provides real time support to analyze the problem, to find possible solution, and to carry out a proper test execution.

COMPRESSION 2000 kN High Stability Blocks

Model	Motorized	LOAD MEASURING SYSTEM	
		Cyber-Plus Evolution mod. C109N (pag. 158)	Servo-Plus Evolution mod. C104N (pag. 158)
C089-21 N	•	•	
C089-22 N	•		•

ACCESSORIES FOR 2000 kN BLOCKS MACHINES:

C111-32 DISTANCE PIECE, 20 mm high for cylinders Ø 150x300 mm

C111-12 DISTANCE PIECE, 73+50 mm high for cubes 200 mm side

C111-13 DISTANCE PIECES, 73+50+50 mm high for cubes 200 and 150 mm side

C111-14 DISTANCE PIECES, 73+50+50+50 mm high for cubes 200, 150 and 100 mm side

C111-24 DISTANCE PIECE 50 mm high

C111-25 DISTANCE PIECE 73 mm high

Note: Cylinders having Ø 160 x 320 mm do not require any distance piece.

C111-50

DISTANCE PIECE

It eliminates the heavy procedure to lift the lower rectangular platen and to add distance pieces.

Technical details: see pag. 247



AS AN ALTERNATIVE:

C112-05

KIT of 4 HANDLES to lift the lower platen, making the positioning of distance pieces easier. Technical details: see pag. 247



C117

SLIDING RAIL CARRIAGE, for an easy removal of the upper block platen, to perform tests on blocks or on standard cubes and cylinders.

C127N GRAPHIC PRINTER on thermo-paper on board

C127-II THERMO-PAPER roll for printer (pack of 10 rolls)

C109-10N SOFTWARE for compression tests with Cyber-Plus Evolution machine. See pag. 14

C123N SOFTWARE "servonet" for remote control through PC of Servo-Plus Evolution machine. See pag. 14

C104-10N

SERVO-STRAIN

Servocontrolled Software, system of:

- Load or Strength
- Displacement
- Strain

This system can be used only with Servo-Plus Evolution machine mod. C089-22N

Technical details see pag. 164

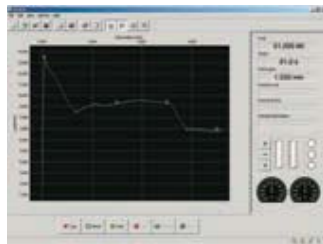

C104-10N

C125N

ELASTIC MODULUS determination of the secant compression on concrete. Automatic system with pace rate control also when releasing the load, applicable only to high stability frames with Servo-Plus Evolution. EN 12390-13, UNI 6556, ASTM C469 ISO 1920-10, DIN 1048. Technical details: see pag. 220

C121-10 SAFETY GUARDS, polycarbonate, with hinges and lock, to CE Directive. See pag. 244

C121-5I STOP SWITCH on safety guard. See pag. 244

C115-0I TWO WAY HYDRAULIC VALVE, connected to the motorized pumping unit of the machine to activate a second frame. Technical details: see pag. 245

C097-01

DUAL LOW CAPACITY DIGITAL RANGE, complete with "appropriate pressure transducer". Recommended range 0-250kN. Technical details: see pag. 240



C097-01

AS AN ALTERNATIVE:

C097-02

DUAL LOW CAPACITY DIGITAL RANGE 0-300kN, complete with "strain gage load cell". Technical details: see pag. 240

C097-05

CLASS 1, starting from 1% of the full range. With a special calibration procedure it is possible to grant Class 1 practically on the full range of the compression machine.

C097-08

OFFICIAL ACCREDIA (Equivalent UKAS, ENAC, DAKKS, SAS, COFRAC etc.) HARDNESS CERTIFICATE of upper and lower compression platens. Minimum hardness: 55 HRC. See pag. 240

C100

SPLITTING TENSILE test device for cylinders. EN 12390-6 / ASTM C496

Technical details and other models: see pag. 241

C103

SPLITTING TENSILE test device for self blocking pavers and cubes. EN 1338, 12390-6

Technical details: see pag. 241

AS AN ALTERNATIVE:

C103-01

SPLITTING TENSILE test device for self blocking pavers and cubes max. dimensions 300 x 500 mm. EN 1338, 12390-6. Technical details: see pag. 241



C103-01

C109-12N

SOFTWARE for splitting tensile tests. Technical details: see pag. 14

C106

FLEXURAL TEST DEVICE for concrete beams. EN 12390-5 / ASTM C78, C293 / AASHTO T97 / BS 1881:118 / NF P18-407 / UNI 613 Technical details: see pag. 242



C106

C109-11N

SOFTWARE for flexural tests on concrete beams. Technical details: see pag. 14

E170

COMPRESSION DEVICE to test cement specimens 40,1 x 40 mm. EN 196 / ASTM C349 Technical details and other models: see pag. 242



E170

C126

BENCH to hold the compression machine. Technical details: see pag. 244



**COMPRESSION TESTING MACHINE 3000 kN CAPACITY
"TESTED FOR HIGH STABILITY"**

To test cubes up to 200 mm side and cylinders up to dia. 160x320 mm

STANDARDS: EN 12390-4 / BS 1881:115 / UNI 6686 part 3 / DIN 51220, 51302 / ASTM C39 / NF P18-411
AASHTO T22 / UNE 83304

TECHNICAL SPECIFICATIONS:

- Max. vertical daylight 334,5 mm
- Compression platens dia. 287x60 mm
- Gauges dia. 250 mm with specific resistance scales for cubes 150 mm and cylinders dia. 150 and 160 mm
- Gauges divisions: 3000 kN div. 10 kN - 600 kN div. 2 kN
- Calibration accuracy: Grade 1.0
- Max. ram travel 60 mm approx.
- Hydraulic device to stop the piston's stroke at its max excursion, to avoid pumping the piston out of the cylinder.
- Power supply: 230V 1 ph 50 Hz 750 W
- Dimensions: 750x450x1500 mm
- Weight: 1200÷1250 kg

section C



208



C089-08D + C127N + C111-13 + C121-07 + C121-51



C089-10A + C127N + C111-13 + C121-07 + C121-51



C089-06+C111-13

COMPRESSION 3000 kN High Stability

Model	Motorized	LOAD MEASURING SYSTEM			
		1 Gauge	2 Gauge	Digitec mod. C108N (pag. 155)	Autotec mod. C098N (pag. 155)
C089-06	•	•			
C089-07	•		•		
C089-08 D	•			•	
C089-10 A	•				•

MATEST

ACCESSORIES FOR 3000 kN MACHINES:

- C111-32** DISTANCE PIECE, 20 mm high for cylinders Ø 150x300 mm
- C111-12** DISTANCE PIECE, 73+50 mm high for cubes 200 mm side
- C111-13** DISTANCE PIECES, 73+50+50 mm high for cubes 200 and 150 mm side
- C111-14** DISTANCE PIECES, 73+50+50+50 mm high for cubes 200, 150 and 100 mm side
- C111-15** DISTANCE PIECES, 50+50 mm high for cylinders Ø 110x220 mm
- C111-24** DISTANCE PIECE 50 mm high
- C111-25** DISTANCE PIECE 73 mm high

C110-20 LOWER COMPRESSION PLATEN, hardened and rectified, dia. 165x50 mm to test cubes 100 mm (as an alternative to the distance piece 50 mm high)



C110-20

Note: Cylinders having Ø 160 x 320 mm do not require any distance piece.

- C127N** GRAPHIC PRINTER on thermo-paper on board for digital models
- C127-11** THERMO-PAPER roll for printer (pack of 10 rolls)
- C109-10** SOFTWARE for compression tests with Digitec machine. See pag. 14
- C123** SOFTWARE "servonet" for remote control through PC of Autotec machine. See pag. 14
- C119-05** FRAGMENT GUARDS, polycarbonate, to CE safety Directive. See pag. 244
- C121-07** SAFETY GUARDS, polycarbonate, with hinges and lock, to CE Directive. See pag. 244
- C121-51** STOP SWITCH on safety guard. See pag. 244
- C107-10** CAPPING RETAINERS (set of two) for cylinders Ø 150mm and 6"
- C107-20** NEOPRENE PADS (set of two) for cylinders Ø 150mm 60 shore A

C110-30
UPPER COMPRESSION PLATEN + SPHERICAL SEAT, to fix on the testing machine in replacement of the standard assembly, to obtain an increased vertical clearance of the testing chamber and to meet the ASTM C39 and AASHTO T22 Specifications. Platen dimensions: dia. 165 x 30 mm. Weight : 10 kg approx. Technical details: pag. 243

C115-01
TWO WAY HYDRAULIC VALVE, connected to the motorized pumping unit of the machine to activate a second frame. Technical details: see pag. 245



C115-01

C097-01
DUAL LOW CAPACITY DIGITAL RANGE, complete with "appropriate pressure transducer", only for digital machines.



C097-01

Recommended range 0-250kN. Technical details: see pag. 240

AS AN ALTERNATIVE:

C097-02 DUAL LOW CAPACITY DIGITAL RANGE 0-300kN, complete with "strain gage load cell", only for digital machines. Technical details: see pag. 240

C097-05
CLASS 1, starting from 1% of the full range. With a special calibration procedure it is possible to grant Class 1 practically on the full range of the compression machine. Applicable only on digital machines.

C097-08
OFFICIAL ACCREDIA (Equivalent UKAS, ENAC, DAKKS, SAS, COFRAC etc.) HARDNESS CERTIFICATE of upper and lower compression platens. Minimum hardness: 55 HRC. See pag. 240

C107-01
AUTO-CENTERING DEVICE for cubes 100 and 150 mm side and cylinders dia. 100 and 150 mm. Technical details: see pag. 243

C100
SPLITTING TENSILE test device for cylinders. EN 12390-6 / ASTM C496
Technical details and other models: see pag. 241



C100

C103
SPLITTING TENSILE test device for self blocking pavers and cubes. EN 1338, 12390-6
Technical details: see pag. 241

C109-12 SOFTWARE for splitting tensile tests with digital machines. Technical details: see pag. 14

C106
FLEXURAL TEST DEVICE for concrete beams. EN 12390-5 / ASTM C78, C293 / AASHTO T97 / BS 1881:118 / NF P18-407 / UNI 6133
Technical details: see pag. 242



C106

C109-11
SOFTWARE for flexural tests on concrete beams with digital machines. Technical details: see pag. 14

E170
COMPRESSION DEVICE to test cement specimens 40,1 x 40 mm. EN 196 / ASTM C349
Technical details and other models: see pag. 242



E170

C126
BENCH to hold the compression machine. Technical details: pag. 244



**COMPRESSION TESTING MACHINE 3000 kN CAPACITY
"TESTED FOR HIGH STABILITY"**

To test cubes up to 200 mm side and cylinders up to dia. 160x320 mm

Cyber-Plus or Servo-Plus Evolution Touch Screen Digital System

STANDARDS: EN 12390-4 / BS 1881:115 / UNI 6686 part 3 / DIN 51220, 51302
ASTM C39 / NF P18-411 / AASHTO T22 / UNE 83304

TECHNICAL SPECIFICATIONS:

- Max. vertical daylight 334,5 mm
- Compression platens dia. 287x60 mm
- Calibration accuracy: Grade 1.0
- Max. ram travel 60 mm approx.
- Hydraulic device to stop the piston's stroke at its max excursion, to avoid pumping the piston out of the cylinder.
- Power supply: 230V 1 ph 50 Hz 750 W
- Dimensions: 750x450x1500 mm
- Weight: 1200÷1250 kg



C089-10 N + C104-04 + C127N + C111-12 + C121-07



C089-08N + C127N + C111-13 + C121-07 + C121-51



C089-10N + C127N + C111-12 + C121-07

ACCESSORIES:

C104-04

CONSOLE HOUSING THE SERVO-PLUS EVOLUTION

The pump assembly and the digital system are encased to enhance the design and look of the machine.

C104-05

ONLINE REMOTE ASSISTANCE PACKAGE

The machine features a connection to Internet through which Matest Customer Service provides real time support to analyze the problem, to find possible solution, and to carry out a proper test execution.

COMPRESSION 3000 kN High Stability

LOAD MEASURING SYSTEM

Model	Motorized	Cyber-Plus Evolution mod. C109N (pag. 158)	Servo-Plus Evolution mod. C104N (pag. 158)
C089-08 N	•	•	
C089-10 N	•		•

section C



210

ACCESSORIES FOR 3000 kN MACHINES:

- C111-32** DISTANCE PIECE, 20 mm high for cylinders Ø 150x300 mm
- C111-12** DISTANCE PIECE, 73+50 mm high for cubes 200 mm side
- C111-13** DISTANCE PIECES, 73+50+50 mm high for cubes 200 and 150 mm side
- C111-14** DISTANCE PIECES, 73+50+50+50 mm high for cubes 200, 150 and 100 mm side
- C111-15** DISTANCE PIECES, 50+50 mm high for cylinders Ø 110x220 mm
- C111-24** DISTANCE PIECE 50 mm high
- C111-25** DISTANCE PIECE 73 mm high
- C110-20** LOWER COMPRESSION PLATEN, hardened and rectified, dia. 165x50 mm to test cubes 100 mm (as an alternative to the distance piece 50 mm high)



C110-20

Note: Cylinders having Ø 160 x 320 mm do not require any distance piece.

- C127N** GRAPHIC PRINTER on thermo-paper on board
- C127-11** THERMO-PAPER roll for printer (pack of 10 rolls)
- C109-10N** SOFTWARE for compression tests with Cyber-Plus Evolution machine. See pag. 14
- C123N** SOFTWARE "servonet" for remote control through PC of Servo-Plus Evolution machine. See pag. 14

- C104-10N** SERVO-STRAIN
Servocontrolled Software, system of:
 - Load or Strength
 - Displacement
 - Strain

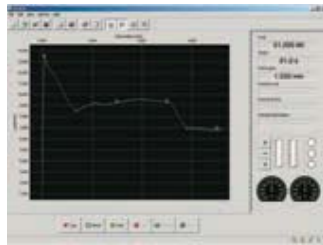

C104-10N

This system can be used only with Servo-Plus Evolution machine mod. C089-10N
Technical details see pag. 164

- C125N** ELASTIC MODULUS determination of the secant compression on concrete. Automatic system with pace rate control also when releasing the load, applicable only to high stability frames with Servo-Plus Evolution. EN 12390-13, UNI 6556, ASTM C469 ISO 1920-10, DIN 1048. Technical details: see pag. 220

- C121-07** SAFETY GUARDS, polycarbonate, complete with hinges and lock to CE Directive. See pag. 244

- C121-51** STOP SWITCH on safety guard. See pag. 244

- C107-10** CAPPING RETAINERS (set of two) for cylinders Ø 150mm and 6"



C107-10

- C107-20** NEOPRENE PADS (set of two) for cylinders Ø 150mm 60 shore A

C110-30

UPPER COMPRESSION PLATEN + SPHERICAL SEAT, to fix on the testing machine in replacement of the standard assembly, to obtain an increased vertical clearance of the testing chamber and to meet the ASTM C39 and AASHTO T22 Specifications. Platen dimensions: dia. 165 x 30 mm. Weight : 10 kg approx. Technical details: see pag. 243

C115-01

TWO WAY HYDRAULIC VALVE, connected to the motorized pumping unit of the machine to activate a second frame. Technical details: see pag. 245



C115-01

C097-01

DUAL LOW CAPACITY DIGITAL RANGE, complete with "appropriate pressure transducer". Recommended range 0-250kN. Technical details: see pag. 240
AS AN ALTERNATIVE:

C097-02 DUAL LOW CAPACITY DIGITAL RANGE 0-300kN, complete with "strain gage load cell". Technical details: see pag. 240

C097-05

CLASS 1, starting from 1% of the full range. With a special calibration procedure it is possible to grant Class 1 practically on the full range of the compression machine.

C097-08

OFFICIAL ACCREDIA (Equivalent UKAS, ENAC, DAKKS, SAS, COFRAC etc.) HARDNESS CERTIFICATE of upper and lower compression platens. Minimum hardness: 55 HRC. See pag. 240

C107-01

AUTO-CENTERING DEVICE for cubes 100 and 150 mm side and cylinders dia. 100 and 150 mm. Technical details: see pag. 243

C103

SPLITTING TENSILE test device for self blocking pavers and cubes. EN 1338, 12390-6
Technical details: see pag. 241



C103

C109-12N

SOFTWARE for splitting tensile tests. Technical details: see pag. 12

C106

FLEXURAL TEST DEVICE for concrete beams. EN 12390-5 / ASTM C78, C293 / AASHTO T97 / BS 1881:118 / NF P18-407 / UNI 6133. Technical details: see pag. 242

C109-11N

SOFTWARE for flexural tests on concrete beams with digital machines. Technical details: see pag. 14



C106

E170

COMPRESSION DEVICE to test cement specimens 40,1 x 40 mm. EN 196 / ASTM C349
Technical details and other models: see pag. 242



E170

C126

BENCH to hold the compression machine. Technical details: see pag. 244



COMPRESSION TESTING MACHINE 3000 kN CAPACITY "TESTED FOR HIGH STABILITY"

To test blocks max. 500x300 mm, cubes up to 200 mm side and cylinders up to dia. 160x320 mm

STANDARDS: EN 12390-4, EN 772-1 / BS 1881:1 15, 6073 / UNI 6686 part 3 / DIN 51220, 51302 / NF P18-411 / ASTM C39, E447
AASHTO T22 / UNE 83304

TECHNICAL SPECIFICATIONS:

- Max. vertical daylight to test blocks: 283 mm
- Compression platens for blocks: 510x320x55 mm
- Max. vertical daylight to test cubes and cylinders: 334,5 mm
- Compression platens to test cubes and cylinders: dia. 287x60 mm
- Gauges dia. 250 mm with specific resistance scales for cubes 150 mm and cylinders dia. 150 and 160 mm
- Gauges divisions: 3000 kN div. 10 kN - 600 kN div. 2 kN
- Calibration accuracy: Grade 1.0
- Max. ram travel 60 mm approx.
- Hydraulic device to stop the piston's stroke at its max excursion, to avoid pumping the piston out of the cylinder.
- Power supply: 230V 1 ph 50 Hz 750 W
- Dimensions: 750x520x1500 mm
- Weight: 1350÷1400 kg

section C



212



C089-19A + C127N

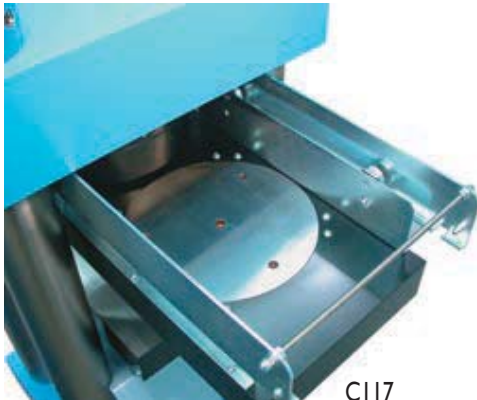

C117



C089-17D + C127N

COMPRESSION 3000 kN High Stability Blocks

Model	Motorized	LOAD MEASURING SYSTEM			
		1 Gauge	2 Gauge	Digitec mod. C108N (pag. 155)	Autotec mod. C098N (pag. 155)
C089-15	•	•			
C089-16	•		•		
C089-17 D	•			•	
C089-19 A	•				•

MATEST

ACCESSORIES FOR 3000 kN BLOCKS MACHINES:

C111-32 DISTANCE PIECE, 20 mm high for cylinders Ø 150x300 mm

C111-12 DISTANCE PIECE, 73+50 mm high for cubes 200 mm side

C111-13 DISTANCE PIECES, 73+50+50 mm high for cubes 200 and 150 mm side

C111-14 DISTANCE PIECES, 73+50+50+50 mm high for cubes 200, 150 and 100 mm side

C111-15 DISTANCE PIECES, 50+50 mm high for cylinders Ø 110x220 mm

C111-24 DISTANCE PIECE 50 mm high

C111-25 DISTANCE PIECE 73 mm high

Note: Cylinders having Ø 160 x 320 mm do not require any distance piece.



C111-50

C111-50

DISTANCE PIECE

It eliminates the heavy procedure to lift the lower rectangular platen and to add distance pieces.

Technical details: see pag. 247

AS AN ALTERNATIVE:

C112-05

KIT of 4 HANDLES to lift the lower platen, making the positioning of distance pieces easier. Technical details: see pag. 247

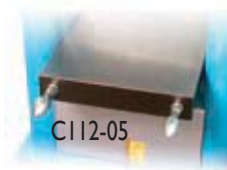

C112-05

C117

SLIDING RAIL CARRIAGE, for an easy removal of the upper block platen, to perform tests on blocks or on standard cubes and cylinders.

C127N GRAPHIC PRINTER on thermo-paper on board for digital models

C127-11 THERMO-PAPER roll for printer (pack of 10 rolls)

C109-10 SOFTWARE for compression tests with Digitec machine. See pag. 14

C123 SOFTWARE "servonet" for remote control through PC of Autotec machine. See pag. 14

C121-08 SAFETY GUARDS, polycarbonate, with hinges and lock, to CE Directive. See pag. 244

C121-51 STOP SWITCH on safety guard. See pag. 244

C115-01

TWO WAY HYDRAULIC VALVE, connected to the motorized pumping unit of the machine to activate a second frame. Technical details: see pag. 245



C115-01

C097-01

DUAL LOW CAPACITY DIGITAL RANGE, complete with "appropriate pressure transducer", only for digital machines. Recommended range 0-250kN. Technical details: see pag. 240

AS AN ALTERNATIVE:

C097-02

DUAL LOW CAPACITY DIGITAL RANGE 0-300kN, complete with "strain gage load cell", only for digital machines. Technical details: see pag. 240



C097-01

C097-05

CLASS 1, starting from 1% of the full range. With a special calibration procedure it is possible to grant Class 1 practically on the full range of the compression machine. Applicable only on digital machines.

C097-08

OFFICIAL ACCREDIA (Equivalent UKAS, ENAC, DAKKS, SAS, COFRAC etc.) HARDNESS CERTIFICATE of upper and lower compression platens. Minimum hardness: 55 HRC. See pag. 240

C100 SPLITTING TENSILE test device for cylinders.

EN 12390-6 / ASTM C496

Technical details and other models: see pag. 241

C103

SPLITTING TENSILE test device for self blocking pavers and cubes.

EN 1338, 12390-6

Technical details: see pag. 241

AS AN ALTERNATIVE:

C103-01

SPLITTING TENSILE test device for self blocking pavers and cubes max. dimensions 300 x 500 mm. EN 1338, 12390-6. Technical details: see pag. 241

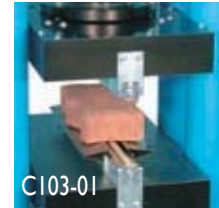

C103-01

C109-12 SOFTWARE for splitting tensile tests with digital machines. Technical details: see pag. 14

C106

FLEXURAL TEST DEVICE for concrete beams. EN 12390-5 / ASTM C78, C293 / AASHTO T97 / BS 1881:118 / NF P18-407 / UNI 6133. Technical details: see pag. 242

C109-11

SOFTWARE for flexural tests on concrete beams with digital machines.

Technical details: see pag. 14



C106

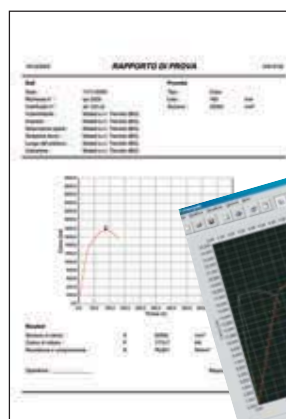

C109-10

Software Compression

E170

COMPRESSION DEVICE to test cement specimens 40,1 x 40 mm. EN 196 / ASTM C349. Technical details and other models: see pag. 242

C126

BENCH to hold the compression machine. Technical details: see pag. 244



E170



COMPRESSION TESTING MACHINE 3000 kN CAPACITY "TESTED FOR HIGH STABILITY"

To test blocks max. 500x300 mm, cubes up to 200 mm side and cylinders up to dia. 160x320 mm

Cyber-Plus or Servo-Plus Evolution Touch Screen Digital System

STANDARDS: EN 12390-4, EN 772-1 / BS 1881:1 15, 6073 / UNI 6686, part 3 / DIN 51220, 51302 / NF P18-41 I
ASTM C39, E447 / AASHTO T22 / UNE 83304



TECHNICAL SPECIFICATIONS:

- Max. vertical daylight to test blocks: 283 mm
- Compression platens for blocks: 510x320x55 mm
- Max. vertical daylight to test cubes and cylinders: 334,5 mm
- Compression platens to test cubes and cylinders: dia. 287x60 mm
- Calibration accuracy: Grade 1.0
- Max. ram travel 60 mm approx.
- Hydraulic device to stop the piston's stroke at its max excursion, to avoid pumping the piston out of the cylinder.
- Power supply: 230V 1 ph 50 Hz 750 W
- Dimensions: 750x520x1500 mm
- Weight: 1350÷1400 kg



C089-19N + C104-04 + C127N

ACCESSORIES:

C104-04

CONSOLE HOUSING THE SERVO-PLUS EVOLUTION

The pump assembly and the digital system are encased to enhance the design and look of the machine.

C104-05

ONLINE REMOTE ASSISTANCE PACKAGE

The machine features a connection to Internet through which Matest Customer Service provides real time support to analyze the problem, to find possible solution, and to carry out a proper test execution.



C089-17N + C127N



C089-19N + C127N



C117

COMPRESSION 3000 kN High Stability Blocks

LOAD MEASURING SYSTEM

Model	Motorized	Cyber-Plus Evolution mod. C109N (pag. 158)	Servo-Plus Evolution mod. C104N (pag. 158)
C089-17 N	•	•	
C089-19 N	•		•



ACCESSORIES FOR 3000 kN BLOCKS MACHINES:

C111-32 DISTANCE PIECE, 20 mm high for cylinders Ø 150x300 mm

C111-12 DISTANCE PIECE, 73+50 mm high for cubes 200 mm side

C111-13 DISTANCE PIECES, 73+50+50 mm high for cubes 200 and 150 mm side

C111-14 DISTANCE PIECES, 73+50+50+50 mm high for cubes 200, 150 and 100 mm side

C111-24 DISTANCE PIECE 50 mm high

C111-25 DISTANCE PIECE 73 mm high

Note: Cylinders having Ø 160 x 320 mm do not require any distance piece.

C111-50

DISTANCE PIECE

It eliminates the heavy procedure to lift the lower rectangular platen and to add distance pieces.

Technical details: see pag. 247



C111-50

AS AN ALTERNATIVE:

C112-05

KIT of 4 HANDLES to lift the lower platen, making the positioning of distance pieces easier. Technical details: see pag. 247

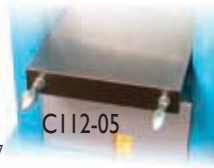

C112-05

C117

SLIDING RAIL CARRIAGE, for an easy removal of the upper block platen, to perform tests on blocks or on standard cubes and cylinders.

C127N GRAPHIC PRINTER on thermo-paper on board

C127-11 THERMO-PAPER roll for printer (pack of 10 rolls)

C109-10N SOFTWARE for compression tests with Cyber-Plus Evolution machine. See pag. 14

C123N SOFTWARE "servonet" for remote control through PC of Servo-Plus Evolution machine. See pag. 14

C104-10N

SERVO-STRAIN

Servocontrolled Software, system of:

- Load or Strength
- Displacement
- Strain

This system can be used only with Servo-Plus Evolution machine mod. C089-19N

Technical details see pag. 164

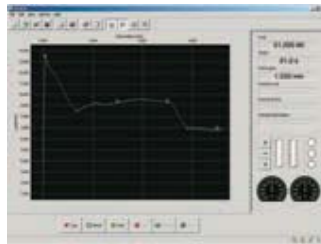

C104-10N

C125N

ELASTIC MODULUS determination of the secant compression on concrete. Automatic system with pace rate control also when releasing the load, applicable only to high stability frames with Servo-Plus Evolution. EN 12390-13, UNI 6556, ASTM C469 ISO 1920-10, DIN 1048. Technical details: see pag. 220

C121-08 SAFETY GUARDS, polycarbonate, with hinges and lock, to CE Directive. See pag. 244

C121-51 STOP SWITCH on safety guard. See pag. 244

C115-01 TWO WAY HYDRAULIC VALVE, connected to the motorized pumping unit of the machine to activate a second frame. Technical details: see pag. 245

C097-01

DUAL LOW CAPACITY DIGITAL RANGE, complete with "appropriate pressure transducer". Recommended range 0-250kN. Technical details: see pag. 240

AS AN ALTERNATIVE:

C097-02

DUAL LOW CAPACITY DIGITAL RANGE 0-300kN, complete with "strain gage load cell". Technical details: see pag. 240



C097-01

C097-05

CLASS 1, starting from 1% of the full range. With a special calibration procedure it is possible to grant Class 1 practically on the full range of the compression machine.

C097-08

OFFICIAL ACCREDIA (Equivalent UKAS, ENAC, DAKKS, SAS, COFRAC etc.) HARDNESS CERTIFICATE of upper and lower compression platens. Minimum hardness: 55 HRC. See pag. 240

C100 SPLITTING TENSILE test device for cylinders. EN 12390-6 / ASTM C496
Technical details and other models: see pag. 241



C100

C103-01

SPLITTING TENSILE test device for self blocking pavers and cubes, max. dimensions 300x500 mm. EN 1338, 12390-6
Technical details: see pag. 241



C103

C109-12N

SOFTWARE for splitting tensile tests. Technical details: see pag. 14

C106

FLEXURAL TEST DEVICE for concrete beams. EN 12390-5 / ASTM C78, C293 / AASHTO T97 / BS 1881:118 / NF P18-407 / UNI 6133. Technical details: see pag. 242



C106

C109-11N

SOFTWARE for flexural tests on concrete beams. Technical details: see pag. 14

E170

COMPRESSION DEVICE to test cement specimens 40,1 x 40 mm. EN 196 / ASTM C349
Technical details and other models: see pag. 242



E170

C126

BENCH to hold the compression machine. Technical details: see pag. 244



**COMPRESSION TESTING MACHINE 4000 kN CAPACITY
"TESTED FOR HIGH STABILITY"**

To test cubes up to 200 mm side and cylinders up to dia. 250x500 mm

Cyber-Plus or Servo-Plus Evolution Touch Screen Digital System

STANDARDS: EN 12390-4 / BS 1881:115 / UNI 6686 part 3 / DIN 51220, 51302

ASTM C39 / NF P18-411 / AASHTO T22 / UNE 83304

NEW



section C



216

TECHNICAL SPECIFICATIONS:

- Max. vertical daylight: 590 mm
- Compression platens dia. 287x60 mm
- Calibration accuracy: Grade 1.0
- Max. ram travel 60 mm approx.
- Hydraulic device to stop the piston's stroke at its max excursion, to avoid pumping the piston out of the cylinder.
- Power supply: 230V 1 ph 50 Hz 750 W
- Dimensions: 1200x900x1900 mm
- Weight: 2800 ≈ 2900 kg



C088-10N



C088-11N

ACCESSORIES:

C104-05

ONLINE REMOTE ASSISTANCE PACKAGE

The machine features a connection to Internet through which Matest Customer Service provides real time support to analyze the problem, to find possible solution, and to carry out a proper test execution.

COMPRESSION 4000 kN High Stability

LOAD MEASURING SYSTEM

Model	Motorized	Cyber-Plus Evolution mod. C109N (pag. 158)	Servo-Plus Evolution mod. C104N (pag. 158)
C088-10 N	•	•	
C088-11 N	•		•

MATEST

ACCESSORIES FOR 4000 kN MACHINES:

C086-10 DISTANCE PIECE 50 mm high

C086-11 DISTANCE PIECE 25 mm high

Note: Vertical daylight of the compression platens is 590 mm.

The operator will have to buy the needed distance pieces to reduce the daylight between the compression platens to get the correct daylight of the specimen under test plus approx.

10 to 15 mm

C112-11

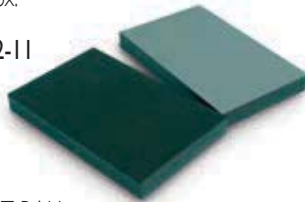

C112-11

UPPER+LOWER LARGE

COMPRESSION PLATENS+SEAT BALL

310x510x55 mm to test "also" blocks. It is necessary to have also the sliding rail carriage mod. C117

C117

SLIDING RAIL CARRIAGE, for an easy removal of the large block upper platen

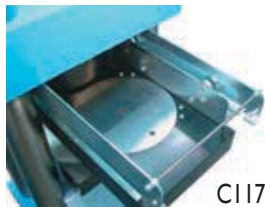

C117

C127N GRAPHIC PRINTER on thermo-paper on board

C127-11 THERMO-PAPER roll for printer (pack of 10 rolls)

C109-10N SOFTWARE for compression tests with Cyber-Plus Evolution machine. See pag. 14

C123N SOFTWARE "servonet" for remote control through PC of Servo-Plus Evolution machine. See pag. 14

C104-10N

SERVO-STRAIN

Servocontrolled Software, system of:

- Load or Strength
- Displacement
- Strain

This system can be used only with Servo-Plus Evolution machine mod. C088-11N

Technical details see pag. 164

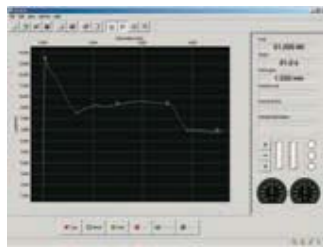

C104-10N

C125N

ELASTIC MODULUS determination of the secant compression on concrete. Automatic system with pace rate control also when releasing the load, applicable only to high stability frames with Servo-Plus Evolution. EN 12390-13, UNI 6556, ASTM C469 ISO 1920-10, DIN 1048.

Technical details: see pag. 220

C121-04 SAFETY GUARDS, polycarbonate, with hinges and lock, to CE Directive. See pag. 244

C121-51 STOP SWITCH on safety guard. See pag. 244

C115-01

TWO WAY HYDRAULIC VALVE, connected to the motorized pumping unit of the machine to activate a second frame.

Technical details: see pag. 245



C115-01

C097-01

DUAL LOW CAPACITY DIGITAL RANGE, complete with "appropriate pressure transducer".

Recommended range 0-250kN

Technical details:

see pag. 240



C097-01

AS AN ALTERNATIVE:

C097-02

DUAL LOW CAPACITY DIGITAL RANGE 0-300kN, complete with "strain gage load cell".

Technical details: see pag. 240

C097-05

CLASS 1, starting from 1% of the full range.

With a special calibration procedure it is possible to grant Class 1 practically on the full range of the compression machine.

C097-08

OFFICIAL ACCREDIA (Equivalent UKAS, ENAC, DAKKS, SAS, COFRAC etc.) HARDNESS CERTIFICATE of upper and lower compression platens. Minimum hardness: 55 HRC. See pag. 240

C107-01

AUTO-CENTERING DEVICE for cubes 100 and 150 mm side and cylinders dia. 100 and 150 mm. Technical details: see pag. 243

C103

SPLITTING TENSILE test device for self blocking pavers and cubes. EN 1338, 12390-6

Technical details: see pag. 241



C103

C109-12N

SOFTWARE for splitting tensile tests. Technical details: see pag. 12

C106

FLEXURAL TEST DEVICE for concrete beams.

EN 12390-5 / ASTM C78, C293 / AASHTO T97 / BS 1881:118 / NF P18-407 / UNI 6133. Technical details: see pag. 242



C106

C109-11N

SOFTWARE for flexural tests on concrete beams with digital machines.

Technical details: see pag. 14

E170

COMPRESSION DEVICE to test cement specimens 40,1 x 40 mm. EN 196 / ASTM C349

Technical details and other models: see pag. 242



E170



**COMPRESSION TESTING MACHINES 3000 kN AND 5000 kN CAPACITY
“TESTED FOR HIGH STABILITY”**

This oversized isostatic high stability stiffness frame grants extreme performances and is the ideal for central and research laboratories for tests on high strength specimens, “explosive samples”, rock and ceramic samples, etc.

Cyber-Plus or Servo-Plus Evolution Touch Screen Digital System

STANDARDS: EN 12390-4 / BS 1881:1 15 / DIN 51220, 51223, 51302 / UNI 6686 part 3 / NF P18-411



section C

TECHNICAL SPECIFICATIONS:

- High stiffness frame: 0,3mm at max. load
- Four chromed columns dia. 150 mm (dia. 180 mm for 5000 kN version)
- Compression platens dia. 316 x 60 mm
- Platens hardness : 60 HRC
- Max. vertical daylight: 411 mm
- Light between columns: 321 mm
- Max. ram travel: 100 mm

- Hydraulic pressure: 360Bar at 3000kN (or 5000 kN)
- Ball seating in oil bath with null end float and up to 3° inclination
- Safety guards to CE Directive polycarbonate and aluminium made
- Grade of accuracy “1”
- Frame size 3000 kN: 725 x 710 x h 1570 mm
- Frame size 5000 kN: 750 x 750 x h 1700 mm
- Power supply: 230V 1ph 50Hz 750W
- Weight frame 3000 kN: 2500 kg
- Weight frame 5000 kN: 4000 kg



218



C088-01N

C087-01N

COMPRESSION 3000/5000 kN High Stability

Model	Code	Motorized	LOAD MEASURING SYSTEM	
			Cyber-Plus Evolution mod. C109N (pag. 158)	Servo-Plus Evolution mod. C104N (pag. 158)
3000 kN	C087 N	•	•	
3000 kN	C087-01 N	•		•
5000 kN	C088 N	•	•	
5000 kN	C088-01 N	•		•

MATEST

ACCESSORIES FOR 3000 kN and 5000 kN MACHINES:

C087-11 DISTANCE PIECE 50 mm high

C087-12 DISTANCE PIECE 25 mm high

Note: Vertical daylight of the compression platens is 411 mm. The operator will have to buy the needed distance pieces to reduce the daylight between the compression platens to get the correct daylight of the specimen under test plus approx. 10 to 15 mm

C112-11

UPPER+LOWER LARGE COMPRESSION PLATENS+SEAT BALL 310x510x55 mm, to test "also" blocks. It is necessary to foresee also the sliding rail carriage mod. C117

C117

SLIDING RAIL CARRIAGE, for an easy removal of the large block upper platen.



C117

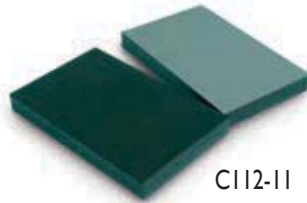

C112-11

C127N

GRAPHIC PRINTER on thermo-paper on board

C127-11 THERMO-PAPER roll for printer (pack of 10 rolls)

C109-10N SOFTWARE for compression tests with Cyber-Plus Evolution machine. See pag. 14

C123N SOFTWARE "servonet" for remote control through PC of Servo-Plus Evolution machine. See pag. 14

C104-10N

SERVO-STRAIN Servocontrolled Software, system of:

- Load or Strength
- Displacement
- Strain

This system can be used only with Servo-Plus Evolution machine mod. C087-01N and C088-01N Technical details see pag. 164

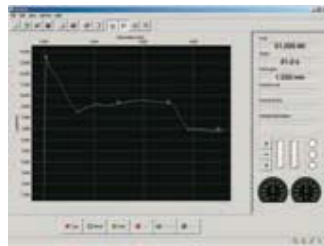

C104-10N

C125N

ELASTIC MODULUS determination of the secant compression on concrete. Automatic system with pace rate control also when releasing the load, applicable only to high stability frames with Servo-Plus Evolution. UNI 6556, ASTM C469, ISO 6784, DIN 1048. Technical details: see pag. 220

C115-01

TWO WAY HYDRAULIC VALVE, connected to the motorized pumping unit of the machine to activate a second frame. Technical details: see pag. 245



C115-01

C097-01

DUAL LOW CAPACITY DIGITAL RANGE, complete with "appropriate pressure transducer". Recommended range 0-250kN. Technical details: see pag. 240



C097-01

AS AN ALTERNATIVE:

C097-02

DUAL LOW CAPACITY DIGITAL RANGE 0-300kN, complete with "strain gage load cell". Technical details: see pag. 240

C097-05

CLASS 1, starting from 1% of the full range. With a special calibration procedure it is possible to grant Class 1 practically on the full range of the compression machine.

C097-08

OFFICIAL ACCREDIA (Equivalent UKAS, ENAC, DAKKS, SAS, COFRAC etc.) HARDNESS CERTIFICATE of upper and lower compression platens. Minimum hardness: 55 HRC. See pag. 240

C100

SPLITTING TENSILE test device for cylinders. EN 12390-6 / ASTM C496 Technical details and other models: see pag. 241



C100

C109-12N

SOFTWARE for splitting tensile tests. Technical details: see pag. 14



C103

C106

FLEXURAL TEST DEVICE for concrete beams. EN 12390-5 / ASTM C78, C293 / AASHTO T97 / BS 1881:118 / NF P18-407 / UNI 6133 Technical details: see pag. 242



C106

C109-11N

SOFTWARE for flexural tests on concrete beams. Technical details: see pag. 14



C123N Software "servonet"

E170

COMPRESSION DEVICE to test cement specimens 40,1 x 40 mm. EN 196 / ASTM C349 Technical details and other models: see pag. 242



E170





C125N C125N + C089-04N + H009-01

Determination of the secant compression ELASTIC MODULUS on concrete
System: Automatic with pace rate control also when releasing the load

STANDARDS: EN 12390-13 / ISO 1920-10:2010 / UNI 6556
 ASTM C469 / DIN 1048

It can be used with a MATEST high stability frame with capacity of 2000 or 3000 or 5000 kN coupled to the automatic servo-controlled system "Servo-Plus Evolution" (mod. C104N) housed in a separate pyramidal frame.

The appliance includes:

- **Hydraulic system**
 It is an hydraulic installation and has a high performance valve directly controlled by the digital unit that grants the automatic control of the pace rate increasing the load, keeps a certain load and than **controls the pace rate decreasing the load**.
 The setting of the pace rate is made by a very sensitive valve controlled by a step by step motor and it allows a micrometric action on the pace rate granting excellent results.
 A laser position detector allows a rapid positioning of the piston. This grants a touching sensitivity of test starting of about 0,1 per thousand of the maximum capacity.
- **Electronic measuring system**
 The high performance control and data processing unit controlled by a 32 bit microprocessor; can manage up to 8 high resolution channels for the control of load cells or transducers with strain gages bridge.
 The unit contains two Analogical/Digital last generation converters with 24 bits resolution. The system processes the signals

Screen during a test and marker indicating any change.

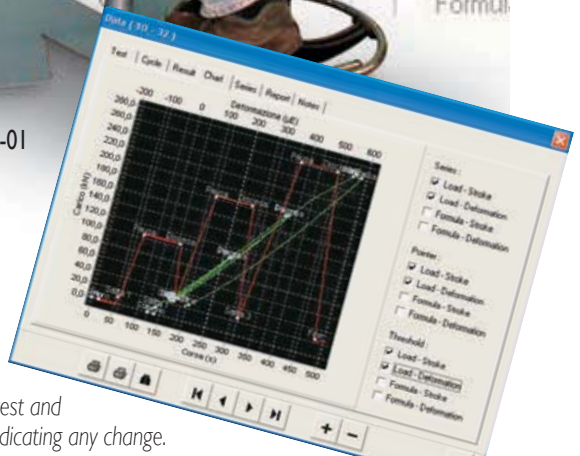

coming from the load cells and from the extensometers giving all the results required for a further processing following the most updated International Standards for this application.

- **Data acquisition and processing software UTM2 License for Elastic Modulus on Concrete.**
 The software has been developed on the working line of the already known software UTM-2 (windows menu). It contains the profiles of the main Standards used, but the user can modify as he likes and personalise the test profile, that will be effected in a completely automatic way by the testing machine.



The user can introduce a list of data concerning the specimen that will be tested and the kind of test that he wants to make: shape of the specimen (cylinder-cube-block), dimensions, age of the specimen, average expected breaking value, etc... The appliance allows verifying the proper reading of the extensometers and, if everything is within the expected tolerances, it manages the average deformation value read by the transducers and processed by the digital unit, than it transmits by means of the communication port RJ (Network Connection) to a Personal Computer; that can be already by the end user or supplied separately all the data of the test. These data will be processed by the software and transformed in a graph load/deformation and load/time, following the International Standards.

The software allows to determine both the initial and stabilized secant modulus of elasticity as requested by EN 12390-13 Standard. The software gives the possibility to print on a standard printer a test certificate reporting all the data concerning the test and the specimen and the graph of the test. The software includes the license "Servonet" mod. C123N, while the extensometers (two models are proposed: **A** and **B**) are not included in the standard supply and must be ordered separately (see accessories).

ACCESSORY:

C125-01N

SOFTWARE FOR ELASTIC MODULUS TESTS ON ROCKS
STANDARDS: ASTM D3148, D2938, D5407, D2264,
UNI 9724-8 – ISRM

NOTE:

The Elastic Modulus on Concrete mod. C125N can be used together with:

- A)** EXTENSOMETERS (STRAIN GAGES), SINGLE USE, ELECTRIC, available in different sizes, mod. C125-10 to C125-13 (see accessories).

or:

- B)** EXTENSOMETERS /COMPRESSOMETERS, electronic, universal, mechanical frame, mod. C134 (see accessories)

ACCESSORIES:

- A)** EXTENSOMETERS (STRAIN GAGES), SINGLE USE, ELECTRIC
Pack of 10 pieces

Available models:

- C125-10** Electric extensometer; base length 10 mm
- C125-11** Electric extensometer; base length 20 mm
- C125-12** Electric extensometer; base length 30 mm
- C125-13** Electric extensometer; base length 60 mm
- C125-14** Electric extensometer; base length 120 mm

C125-15

KIT for the application of single use extensometers composed by: glue, welder; solder; cleaning liquid, accessories, the whole in carrying case.

C125-09

INTERFACE MODULE, "needed accessory" to connect up to 4 electric single use extensometers. This module allows also the automatic calibration of the zero and of the measuring range after a special thermal compensation. This grants a five times better accuracy than the one requested by the Standards.



C125-09

AS AN ALTERNATIVE:

B) C134

EXTENSOMETER / COMPRESSOMETER, ELECTRONIC, UNIVERSAL, MECHANICAL FRAME. It can be used only with samples having minimum height of 130 mm.

Technical details: see pag. 222



C134

C134-10

TEMPLATE, to regulate and calibrate the base length of the C134 extensometer.

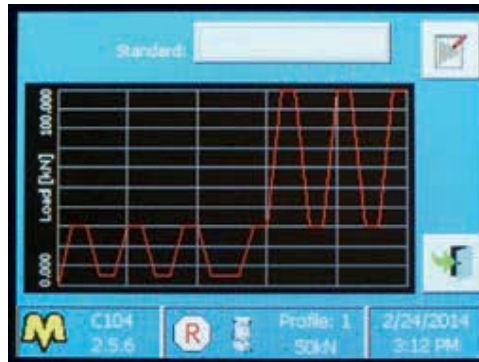

Test graph to EN 12390-13



Test with longitudinal and transversal deformations

Test	Point	Cycle	Series	Chart	Repeat	Name	Symbol	Value	Unit
1	1					Base deformation 1	μm	38,833	μm
1	2					Base deformation 2	μm	48,9	μm
1	3					Base deformation 3	μm	51,367	μm
1	4					Advanced deformation 1	μm	153,439	μm
1	5					Advanced deformation 2	μm	279,767	μm
1	6					Advanced deformation 3	μm	392,467	μm
1	7					Base strength 1	MPa	1,143	MPa
1	8					Base strength 2	MPa	1,136	MPa
1	9					Base strength 3	MPa	1,162	MPa
1	10					Advanced strength 1	MPa	6,937	MPa
1	11					Advanced strength 2	MPa	8,915	MPa
1	12					Advanced strength 3	MPa	11,866	MPa
1	13					Compression module 1	MPa	2989,164	MPa
1	14					Compression module 2	MPa	29627,405	MPa
1	15					Compression module 3	MPa	30239,276	MPa

Test data

... follows...

DETERMINATION OF THE SECANT COMPRESSION ELASTIC MODULUS TEST ON CONCRETE AND MORTAR SPECIMENS

CI34

Electronic Universal EXTENSOMETER/COMPRESSOMETER

STANDARDS: ASTM C469 / ISO 6784 / BS 1881:121 / DIN 1048:1

Made of two anodized aluminium pieces, one fixed and the other sliding and housing a displacement transducer that measures with high accuracy the movement of two conical points made of hardened steel and fixed at the two ends of the electronic sensor.

An aluminium template (optional mod CI34-10) is used to regulate and to calibrate the base length.

The two conical points are coupled to the surface of the sample with a rapid and simple fixing system through two elastic adjustable straps.

The instrument is equipped of a mechanical knob to lock and unlock the displacement transducer; allowing to maintain safe the selected base length during the fixing action of the device to the sample.

Normally the test is performed on cylinders by using 3 extensometers/compressometers, and on cubes or beams by using 2 or 4 instruments.

The extensometer is suitable to test cubes, cylinders and beam specimens, having minimum height of 130 mm.

It is also possible to test mortar prisms 40x40x160 mm by using a reducing length block.

Gauge length adjustable from 50 to 160 mm

Feeding up to 10V

Travel: +/- 1,5 mm

Sensitivity less than 0,01 micron

Supplied complete with reducing block for mortar prisms, elastic straps, carrying case.

Weight: 1000 g approx.

ACCESSORIES:

CI34-10 TEMPLATE, anodized aluminium made, used to regulate and calibrate the base length.

S337-51 CALIBRATION PROCESS of one Extensometer/ Compressometer combined with digital unit.

NOTE:

The Compressometers and the Compressometer/Extensometer connected to electronic linear transducers (accessory mod. S336-11) can be used with:

- Matest Servo-Plus Evolution compression machines equipped with Automatic Elastic Modulus system (mod. CI25N) in complete accordance with ASTM C469, ISO 1920-10:2010, UNI 6556 Specifications (see page 220)
- Matest Cyber-Plus and Servo-Plus compression machines. The electric cable of the displacement transducer is "directly" connected to one of the eight channels available on the digital unit. Through the suitable Software (accessory mod. CI30-05), the digital unit will automatically elaborate the data, supplying the load/deformation graphic with certificate printing.



CI34 with case



Set of 3 units fixed to a cylinder

CI34-10

Block for 40x40x160 mm specimens

CI30-05

FIRMWARE for Elastic Modulus test on Concrete, Mortar and Rock specimens.

Automatic data and processing acquisition, load/deformation graphic and certificate printing with direct management of the testing machine. The software can be installed only on Cyber and Servo-Plus Evolution systems.



CI30-05 Test execution

NOTE:

The Elastic Modulus test, to fully comply ASTM C469 or ISO 1920-10:2010 Standards, must be carried out with a Servo-Plus Matest machine equipped with CI25N automatic system with pace rate load and "unload" control.



STATIC ELASTIC MODULUS OF CONCRETE

Compressometer

Used to determine the strain and deformation characteristics of concrete specimens. It comprises two steel rings for clamping to the specimen, two gauge length bars, and spherically-seated lever unit. Supplied "without" dial gauge or strain transducer to be ordered separately (see accessories).

C132N + S375



C131N + S375



C130N + S375



AVAILABLE MODELS:

C130N COMPRESSOMETER for cylinders dia. 150x300mm; dia. 160x320mm; dia. 6"x12"

C131N COMPRESSOMETER for cylinders dia. 100x200mm; dia. 112,8x220mm; dia. 4"x8"

C132N COMPRESSOMETER for cubes 150 mm side.

C132-01N COMPRESSOMETER for cubes 200 mm side.



NEEDED ACCESSORY:

S375

DIAL GAUGE, 5 mm travel by 0,001 mm subd.

AS AN ALTERNATIVE:

S336-11

ELECTRONIC LINEAR DISPLACEMENT TRANSDUCER, 10 mm travel, complete with cable. Technical details: see pag. 453

NOTE:

The Compressometers and the Compressometer/Extensometer connected to electronic linear transducers (accessory mod. S336-11) can be used with:

- Matest Servo-Plus Evolution compression machines equipped with Automatic Elastic Modulus system (mod. C125N) in complete accordance with ASTM C469, ISO 1920-10:2010, UNI 6556 Specifications (see page 220)
- Matest Cyber-Plus and Servo-Plus compression machines. The electric cable of the displacement transducer is "directly" connected to one of the eight channels available on the digital unit. Through the suitable Software (accessory mod. C130-05), the digital unit will automatically elaborate the data, supplying the load/deformation graphic with certificate printing.

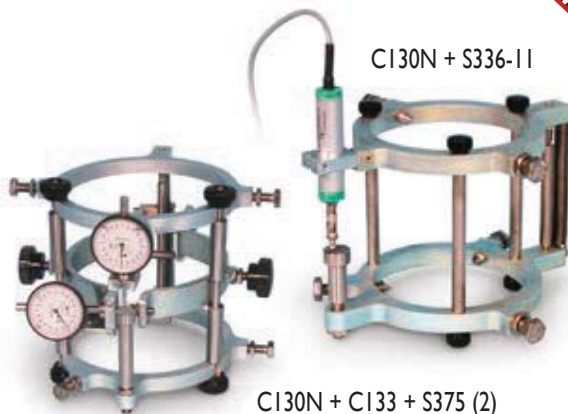

C130N + S336-11

C130N + C133 + S375 (2)

C133

Compressometer-Extensometer

STANDARD: ASTM C469

To measure both axial deformation and diametrical extension of cylinder specimens dia. 150x300mm, 160x320mm, 8"x 12" under compression stress, by determining the elastic modulus.

It consists of a central ring for the diametrical extension measure, "to be fixed on the C130N compressometer".

Supplied "without" dial gauges or linear strain transducers (two required) to be ordered separately (see accessories).



C130N + C133 + S336-11 (2)

C130-05

SOFTWARE for Elastic Modulus test on Concrete and Mortar specimens.

Automatic data and processing acquisition, load/deformation graphic and certificate printing with direct management of the testing machine. The software can be used only with Cyber and Servo-Plus Evolution systems.

S337-51

CALIBRATION PROCESS of one displacement transducer S336-11 combined with Cyber or Servo-Plus Matest compression machine.

NOTE:

The Elastic Modulus test, to fully comply ASTM C469 or ISO 1920-10:2010 Standards, must be carried out with a Servo-Plus Matest machine equipped with C125N automatic system with pace rate load and "unload" control.



FLEXURE TESTING MACHINES

- Motorized or hand operated models,
- Gauge load measuring system,
- "Digitec" or "Cyber-Plus Evolution" graphic display unit,
- "Autotec" or "Servo-Plus Evolution" servo-controlled automatic system.
- Stand alone frame, or combined to another frame.
- Possibility of two point loading as prescribed by EN 12390-5 Spec., or centre point loading by simply removing one upper roller and placing the other in the centre.

WE PROPOSE DIFFERENT FLEXURAL FRAMES:



C090 SERIE



C091 SERIE

- **C090** Serie with frame to perform flexural tests on concrete beam specimens having max. dimensions of 150x150x750 mm conforming to the Specifications: **EN 12390-5** UNI 6133 / ASTM C78, C293 / AASHTO T97 BS 1881:118 / UNE 83305 / NF P18-407 DIN 51227
See pag. 226

- **C091** Serie with "open sided frame" to perform flexural tests on concrete beam specimens having max. dimensions of 200x200x800 mm conforming to the a.m. Specifications, and in addition to perform tests on:
 - Flat blocks (max. width 600 mm) conforming to the BS 6073-1
 - Flagstones and Kerbs conforming to **EN 1340:2004** / BS 7263-1
 - Kerbs conforming to the NF P98-302
 - Any type of beam having max. size 600xh250 mm (lower rollers max. length 1325 mm)
 See pag. 228





C090-06 SERIE

- **C090-06** Serie with high stiffness flexure frame 200 kN capacity to perform tests on concrete beams max. dimensions 150x150x750 mm, and in addition tests on:
 - Flat blocks, max. width 600 mm (BS 6073-1)
 - Flagstones and Kerbs (BS 7263, NF P98-302)
 - Any type of beam having max. width 600 mm and max. height 150 mm
 - Energy absorption on sprayed concrete samples (EN 14488-3, 14488-7, UNI 10834)
- See pag. 230

section C



225

- **C093** Serie to perform flexural tests on concrete beam specimens having max. dimensions 200x200x800 mm and to perform tests on any kind of other product with max. dimensions 550xh550 mm (adjustable distance between lower rollers up to max. 1325 mm)
- See pag. 234

It is also possible, by using suitable accessories, to perform the following tests:

Ductility on fiber reinforced concrete (FRC), and concrete with polymer fibre lining (FRP)

Standards: EN 14651, I 1039-2 / ASTM C1018 (see pag. 232)

Measurement of deflection on concrete beams 100x100x400/500 mm and 150x150x600 mm.

Standard: ASTM C1018 (see pag. 232)

- Compression test on portions of 40.1x40x160 mm mortar prisms broken in flexure conforming to EN 196, DIN 1164 Specifications (compression devices mod. E170, E170-01 - see pag. 242)
- Compression tests on 50 mm mortar cubes, conforming to ASTM C109 (Compression device mod. E171 - see pag. 242)
- Compression tests on 70 mm mortar cubes, conforming to BS 4550 (Compression device mod. E171-01 - see pag. 242)
- Splitting tensile test on cylindrical specimens dia. 100, 150, 160 mm conforming to EN 12390/6 / NF P18-408 / BS 1881:117 ASTM C496 / UNI 6135 (Device mod. C101-01 - see pag. 241)
- Splitting tensile test on concrete cubes and concrete block pavers, conforming to EN 12390/6, 1338 (Device mod. C103 - see pag. 241)



C093 SERIE

MATEST

FLEXURAL TESTING MACHINE 150 kN CAPACITY

To perform flexural tests on concrete beam specimens max. dimensions 150x150x600 (750) mm

STANDARDS: EN 12390-5 / ASTM C78, C293 / AASHTO T97 / BS 1881:118 / NF P18-407 / UNE 83305 / UNI 6133 / DIN 5127

TECHNICAL SPECIFICATIONS:

- Max. vertical daylight between upper/lower rollers: 160 mm
- Rollers dimensions: dia. 40x160 mm
- Complete with 4 adjustable and articulated rollers for two point loading
- Distance between lower rollers adjustable from 100 to 455 mm
- Distance between upper rollers adjustable from 40 to 155 mm
- Possibility to easily place in the centre one upper roller for centre point loading
- Rollers are hardened, casehardened and rectified
- Graduated scales are foreseen to get easy roller's adjustment
- Gauge diameter 250 mm and div. 0.5 kN
- Max. ram travel 50 mm approx.
- Calibration accuracy: grade 1.0
- Hydraulic device to stop the piston's stroke at its max excursion, to avoid pumping the piston out of the cylinder
- Power supply (motorized models): 230V 1 ph 50 Hz 750 W
- Dimensions: 540x460x960 mm
- Weight: 180÷240 kg.



C090-03N + C104-04 + C127N



C090-02N + C127N



C090-02D + C127N



C090-01 + C111-16

FLEXURAL 150 kN capacity

LOAD MEASURING SYSTEM

Model	Hand Operated	Motorized	Gauge	Cyber-Plus Evolution mod. C109N (pag. 158)	Servo-Plus Evolution mod. C104N (pag. 158)	Digitec mod. C108N (pag. 155)	Autotec mod. C098N (pag. 155)
C090	•		•				
C090-01		•	•				
C090-02 N		•		•			
C090-03 N		•			•		
C090-02 D		•				•	
C090-03 A		•					•



ACCESSORIES FOR 150 kN FLEXURAL MACHINES:

- C111-16** DISTANCE PIECE, 50 mm high to test beams 100x100x400/500 mm
- C127N** GRAPHIC PRINTER on thermo-paper on board for digital models
- C127-11** THERMO-PAPER roll for printer (pack of 10 rolls)
- C109-11** SOFTWARE for flexure tests with Cyber-Plus Evolution machine (see pag. 14)
- C109-11** SOFTWARE for flexure tests with Digitec machine (see pag. 14)
- C123** SOFTWARE "servonet" for remote control through PC of Autotec machine (see pag. 14)
- C123N** SOFTWARE "servonet" for remote control through PC of Servo-Plus Evolution machine (see pag. 14)

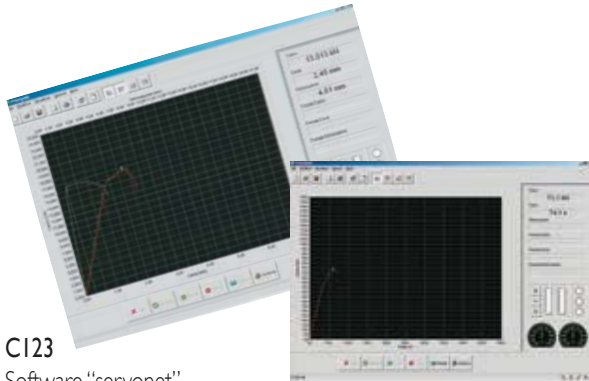

C123 Software "servonet"

C109-11 Software Flexure

C115-01

TWO WAY HYDRAULIC VALVE, connected to the motorized pumping unit of the machine to activate a second frame. Technical details: see pag. 245



C115-01

C104-04

CONSOLE HOUSING THE SERVO-PLUS EVOLUTION, the pump assembly are encased to enhance the design of the machine.

C097-01

DUAL LOW CAPACITY DIGITAL RANGE, complete with "appropriate pressure transducer", only for digital machines. Range selectable from 10kN to 100kN. Technical details: see pag. 240



C097-01

C097-05

CLASS 1, starting from 1% of the full range. With a special calibration procedure it is possible to grant Class 1 practically on the full range of the compression machine. Applicable only on digital machines.



C100

C100

SPLITTING TENSILE test device for cylinders. EN 12390-6 / ASTM C496. Technical details and other models: see pag. 241

C093-11

DEVICE for flexural tests on clay blocks. STANDARD: UNI 9730-3. Technical details: see pag. 249

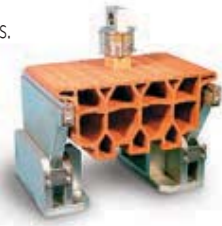

C093-11

C109-16N

SOFTWARE for flexural tests on clay blocks (see pag. 14)

C103

SPLITTING TENSILE test device for self blocking pavers and cubes. EN 1338, 12390-6. Technical details: see pag. 241



C103

C109-12 SOFTWARE for splitting tensile tests with Digitec machines. Technical details: see pag. 14

C109-12N SOFTWARE for splitting tensile tests with Cyber-Plus Evolution machine. Technical details: see pag. 14



C109-12 Graphic of splitting tensile test execution

E170

COMPRESSION DEVICE to test cement specimens 40,1 x 40 mm. EN 196 / ASTM C349. Technical details and other models: see pag. 242



E170

E172-01

FLEXURE DEVICE for cement prisms 40,1x40x160 mm. EN 196 / EN ISO 679 (it can be used only with the dual low capacity digital range 0-15kN). Technical details and other models: see pag. 352



E172-01

C126

BENCH to hold the compression machine. Technical details: see pag. 244



C126



FLEXURAL TESTING MACHINE 150kN CAPACITY “OPEN SIDED FRAME”

To perform flexural tests on concrete beam specimens max. dimensions 200x200x800mm, flat blocks, flagstones, kerbs, tiles, slabs, masonry units, and any type of material having max. size 600x250 mm (lower rollers max. length 1325 mm)

STANDARDS: EN 12390-5 / EN 1340:4 / ASTM C78, C293 / AASHTO T97 / BS1881 :118, BS 6073-1, BS 7263 / UNE 83305
NF P18-407, P98-302 / DIN 51227 / UNI 6133

TECHNICAL SPECIFICATIONS :

- “Open sided frame” for an easy and fast positioning of the specimen between the rollers
- Max. vertical daylight between upper/lower rollers: 260 mm, with possibility to select intermediate daylight positions of 210, 160, 110 and 60 mm
- Rollers dimensions: dia. 40 x 613 mm
- Possibility to easily place in the centre one upper roller for centre point loading
- Graduated scales are foreseen to get easy roller’s adjustment
- Gauge diameter 250 mm and div. 0,5 kN
- Ram travel 110mm approx.
- Calibration accuracy: grade 1.0
- Simple action piston with counterweights to optimise frictions
- Power supply: 230V 1ph 50Hz 750W
- Dimensions: 1400 x 1200 xh 1430 mm
- Weight: 350 kg

section C



228



C091-02D + C127N + C091-12



C091-02N + C127N + C091-12



C091-03N + C127N + C091-12

THE FRAME IS SUPPLIED “WITHOUT” UPPER/LOWER ROLLERS GROUP, TO BE ORDERED SEPARATELY (Possibility to choose between different types of rollers-group. See accessories).

FLEXURAL 150 kN capacity

Model	Motorized	LOAD MEASURING SYSTEM				
		Gauge	Cyber-Plus Evolution mod. C109N (pag. 158)	Servo-Plus Evolution mod. C104N (pag. 158)	Digitec mod. C108N (pag. 155)	Autotec mod. C098N (pag. 155)
C091-01	•	•				
C091-02 N	•		•			
C091-03 N	•			•		
C091-02 D	•				•	
C091-03 A	•					•

MATEST

ACCESSORIES FOR FLEXURAL 150 kN "OPEN SIDED FRAME":

C091-10

ROLLERS GROUP: lower adjustable from 75 to 525 mm, and "only one" upper central roller for single point method.

C091-11

ROLLERS GROUP: lower adjustable from 75 to 525 mm, and upper adjustable from 75 to 180 mm for two points method.

C091-12

ROLLERS GROUP: lower adjustable from 75 to 1325 mm, and upper adjustable from 75 to 575 mm for two points method.

C091-14

ROLLERS GROUP: lower adjustable from 75 to 1325 mm, and "only one" upper central roller for single point method.



C091-13

UPPER TAMPER (steel made), for concrete KERBS tests. The tamper is mounted on a rotating coupling and fixed to the upper part of the machine to apply a flexural strength on three points on the kerb, without any torsional stress. STANDARD: EN 1340, 1339

C090-15

DEFLECTION MEASUREMENT TEST on fiber reinforced concrete beams 100x100x400(500) mm and 150x150x500(600) mm STANDARDS: EN 11039-02, 14487-1, 14488-3 ASTM C1609, C1609M

The test is performed with the specific equipment (deflection measurement device, displacement transducers) described at pag. 232 and the automatic servocontrolled system of load and displacement Servoplus (see pag. 164)

C109-15N

Software for deflection measurement test on fiber reinforced concrete (see pag. 14)



C090-15



C093-11

C093-11 DEVICE for flexural tests on clay blocks for flooring. STANDARD: UNI 9730-3

C109-16N

SOFTWARE for flexural tests on clay blocks (see pag. 14)

C127N GRAPHIC PRINTER on thermo-paper on board for digital models

C127-11 THERMO-PAPER roll for printer (pack of 10 rolls)

C109-11 SOFTWARE for flexure tests with Digitec and Cyber-Plus Evolution machines. See pag. 14

C123 SOFTWARE "servonet" for remote control through PC of Autotec and Servo-Plus Evolution machines. See pag. 14



C115-01

C115-01

TWO WAY HYDRAULIC VALVE, connected to the motorized pumping unit of the machine to activate a second frame. Technical details: see pag. 245

C097-01

DUAL LOW CAPACITY DIGITAL RANGE, complete with "appropriate pressure transducer", only for digital machines. Range selectable from 10kN to 100kN. See pag. 240



C097-01

C097-05

CLASS 1, starting from 1% of the full range. With a special calibration procedure it is possible to grant Class 1 practically on the full range of the compression machine. Applicable only on digital machines.

C100

SPLITTING TENSILE test device for cylinders. EN 12390-6 / ASTM C496 Technical details and other models: see pag. 241

C103

SPLITTING TENSILE test device for self blocking pavers and cubes. EN 1338, 12390-6 Technical details: see pag. 241



C103

AS AN ALTERNATIVE:

C103-02

SPLITTING TENSILE test device for self blocking pavers and cubes, max. dimensions 300x500 mm. EN 1338, 12390-6 Technical details: see pag. 241



C103-02

C109-12

SOFTWARE for splitting tensile tests with digital machines. Technical details: see pag. 14



E170

E170

COMPRESSION DEVICE to test cement specimens 40,1 x 40 mm. EN 196 / ASTM C349 Technical details and other models: see pag. 242

E172-01

FLEXURE DEVICE for cement prisms 40,1x40x160 mm. EN 196 / EN ISO 679 (it can be used only with the dual low capacity digital range 0-15kN). Technical details and other models: see pag. 352



E172-01



Flexural frame “high stiffness” stability **CAPACITY 200 kN**

To perform flexural tests on concrete beams max. dimensions 150x150x600/750 mm, flat blocks, flagstones, kerbs, tiles, slabs, masonry units, and any type of material having max. width 600 mm and max. height 150 mm.

STANDARDS: EN 12390-5 / EN 1340:4 / BS 1881:1 18, 6073-1, 7263 / ASTM C78, C293 / AASHTO T97 / NF P18-407, P98-302 / UNE 83305
DIN 51227

TECHNICAL SPECIFICATIONS:

- High stiffness frame with minimum deflection at maximum load (0,9 mm)
- Capacity load: 200 kN
- Max. vertical daylight between upper/lower rollers: 160 mm
- Ram travel: 110 mm, to obtain minimum daylight of 50 mm
- Horizontal daylight of the testing chamber: 720 mm
- Graduated scales are foreseen to get easy roller's adjustment
- Simple action piston with counterweights to optimize frictions
- Power supply: 230V 1ph 50Hz 750W
- Dimensions: 990 x 970 xh 1105 mm
- Weight : 190 - 250 kg

THE FRAME IS SUPPLIED “WITHOUT ” UPPER/LOWER ROLLERS GROUP,TAMPER, BASE SUPPORT ETC.TO BE ORDERED SEPARATELY (see accessories).



C090-07N + C127N + C104-04 + C090-13



C090-06N + C127N + C090-13



C090-07A + C127N + C090-13

FLEXURAL 200 kN capacity High Stiffness

Model	Capacity kN	LOAD MEASURING SYSTEM			
		Cyber-Plus Evolution mod. C109N (pag. 158)	Servo-Plus Evolution mod. C104N (pag. 158)	Digitec mod. C108N (pag. 155)	Autotec mod. C098N (pag. 155)

C090-06 N	200	•			
C090-07 N	200		•		
C090-06 D	200			•	
C090-07 A	200				•

section C



230

MATEST

ACCESSORIES FOR FLEXURAL 200 kN "HIGH STIFFNESS":

Rollers, dia. 40 mm, hardened and rectified, cadmium plated against corrosion.

Lower rollers have adjustable distance from 75 to 900 mm, and upper rollers have adjustable distance from 75 to 180 mm for two points loading tests.

Possibility to easily place in the centre one upper roller for centre point loading tests.

Models:

C090-12 ROLLERS GROUP upper and lower; 160 mm long.

C090-13 ROLLERS GROUP upper and lower; 613 mm long.

ACCESSORY FOR C090-13:

C090-21

ROLLERS-HOLDERS (lowers only) 613 mm long, to be installed on the C090-13 group in order to modify the max. vertical daylight at 60 mm and min. at -50 mm to test tiles, slabs etc. with max. thickness of 50 mm and flexibility up to -45 mm.

C090-14

ENERGY ABSORPTION TEST on sprayed concrete specimens. STANDARDS: **EN 14488-5, comparable to EN 10834**

The test is performed with the specific equipment (square base 700x700 mm, loading element, displacement transducer) described at pag. 203 and the Software/Firmware automatic system of load and displacement **Servo Strain** (pag. 164)



C090-14

C090-15

DEFLECTION MEASUREMENT TEST on fiber reinforced concrete beams 100x100x400(500) mm and 150x150x500(600) mm STANDARDS: **EN 11039-02, 14487-1, 14488-3 / ASTM C1609, C1609M**

The test is performed with the specific equipment (deflection measurement device, displacement transducers) described at pag. 202 and the Software/Firmware automatic system of load and displacement **Servo Strain** (pag. 164)



C090-15

C109-15N

SOFTWARE for energy absorption test on sprayed concrete specimens and deflection measurement tests on fiber reinforced concrete beams (see pag. 14)

C091-13

UPPER TAMPER (steel made), for concrete KERBS tests.

The tamper is mounted on a rotating coupling and fixed to the upper part of the machine to apply a flexural strength on three points on the kerb, without any torsional stress.

STANDARD: EN 1340, 1339



C091-13

C093-11

DEVICE for flexural tests on clay blocks for flooring. STANDARD: UNI 9730-3



C093-11

C109-16N SOFTWARE for flexural tests on clay blocks (see pag. 14)

C127N GRAPHIC PRINTER on thermo-paper on board

C127-11 THERMO-PAPER roll for printer (pack of 10 rolls)

C109-11 SOFTWARE for flexure tests with Digitec and Cyber-Plus Evolution machines. See pag. 14

C123

SOFTWARE "servonet" for remote control through PC of Autotec and Servo-Plus Evolution machines. See pag. 14



C097-01

C097-01

DUAL LOW CAPACITY DIGITAL RANGE, complete with "appropriate pressure transducer". Range selectable from 10kN to 100kN. Technical details: see pag. 240

C097-05

CLASS 1, starting from 1% of the full range. With a special calibration procedure it is possible to grant Class 1 practically on the full range of the compression machine.

C100

SPLITTING TENSILE test device for cylinders. EN 12390-6 / ASTM C496 Technical details and other models: see pag. 241



C100

C103

SPLITTING TENSILE test device for self blocking pavers and cubes. EN 1338, 12390-6 Technical details: see pag. 241



C103

AS AN ALTERNATIVE:

C103-02

SPLITTING TENSILE test device for self blocking pavers and cubes, max. dimensions 300x500 mm. EN 1338, 12390-6 Technical details: see pag. 241



C103-02

C109-12

SOFTWARE for splitting tensile tests. Technical details: see pag. 14

E170

COMPRESSION DEVICE to test cement specimens 40,1 x 40 mm. EN 196 / ASTM C349

Technical details and other models: see pag. 242

E172-01

FLEXURE DEVICE for cement prisms 40,1x40x160 mm. EN 196 / EN ISO 679 (it can be used only with the dual low capacity digital range 0-15kN). Technical details and other models: see pag. 352



Measurement of deflection on fibre reinforced concrete beams 100x100x400(500) mm and 150x150x500(600) mm during flexure test.

STANDARD: ASTM C1609, C1609M, comparable to UNI 14651

Determination of toughness, first crack strength (crack opening) and ductility of fibre reinforced concrete. STANDARD: EN 11039-2

Flexural strengths (first peak, ultimate and residual) of fibre reinforced beam specimens. STANDARD: EN 14488-3

The equipment can be used "only" with the flexure Servo-Plus Evolution testing machines mod:

- **C091-03N** Flexure "open-side" machine, 150kN capacity
- **C090-07N** Flexure "high stiffness" frame 200kN capacity connected to the Software/Firmware "Servo-Strain" mod. C109-15N (see pag. 164) for the automatic management of load and displacement.



C090-15

The equipment consists of:

C090-15

DEFLECTION MEASUREMENT DEVICE

STANDARD: ASTM C1609, C1609M

This device is fixed directly on the fiber reinforced concrete beam under test.

The device is placed between the loading bearers of a flexure frame to be selected between the above listed models.

The test is performed by applying a flexural load to the concrete beam with load and displacement control and with the automatic deflection measurement of the loaded specimen.

It is possible to test fiber reinforced concrete beams 100x100x400 or 500 mm and 150x150x500 or 600 mm dimensions.

The deflection device is steel made with chromed finishing; it is supplied complete with transducer's holders, vertically fixed on the two opposite sides of the beam, but "without" the two transducers, for the measurement of deflection (mod. S336-11), and "without" the fork form transducer (mod. C090-16) to be ordered separately.

Dimensions: 300x450x300 mm. Weight: 8 kg

S336-11

DISPLACEMENT TRANSDUCER, high precision.

STANDARD: ASTM C1609, C1609M

To be fixed to the device C090-15 for the measurement of deflection and determination of toughness on fibre reinforced concrete beams. Travel: 10 mm

Complete with cable and connector.

Two transducers are required.

C109-15N

FIRMWARE/SOFTWARE for:

- Measurement of deflection on fibre reinforced concrete beams.
- Determination of toughness, first crack strength and ductility.
- Energy absorption test on sprayed specimens. (see pag. 14)

C109-14N

FIRMWARE/SOFTWARE for flexural strengths (first peak, ultimate and residual) EN 14488-3

C090-20

DATUM BLOCK, square, to be glued on the concrete beam surface for the deflection measurement on the two opposite sides (CTOD). Pack of 24 pieces.

C090-16

FORK FORM TRANSDUCER

STANDARD: EN 11039-2

For the measurement of the Crack Mouth Opening Displacement (CMOD) and the Crack Base, Medium and Tip Opening Displacement (CTOD). Measuring range: 5 mm

Complete with cable and connector.

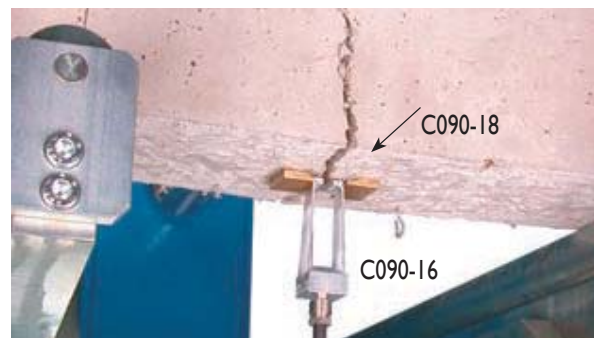

C090-18

C090-16

C090-18 DATUM BLOCK, to be glued on the concrete beam lower side for the first crack strength test (CMOD). Pack of 24 pieces.



C090-07N + C090-13 + C109-15N + C090-15 + S336-11



C090-18

C090-20



Energy absorption test on sprayed concrete specimens, according to:
Standards: EN 14488-05, comparable to EN 10834

The equipment can be used “only” with the flexure Servo-Plus Evolution testing machine mod:

- **C090-07N** Flexure “high stiffness” frame 200kN capacity connected to the automatic servocontrolled system of load and displacement **Servo-Strain** mod C109-15N (see pag. 164)

The equipment consists of:

C109-15N

FIRMWARE/SOFTWARE for:

- Measurement of deflection on fibre reinforced concrete beams.
 - Determination of toughness, first crack strength and ductility.
 - Energy absorption test on sprayed specimens.
- (see pag. 14)



C109-15N Test result

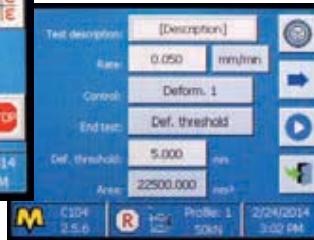

C109-15N Set up of deflection



C090-07N + C109-15N + C090-14 + S336-14 + C090-19

C090-14

SQUARE BASE FRAME, dimensions 700 x 700 mm, complete with upper loading element, for energy absorption tests on sprayed concrete specimens.

S336-14

DISPLACEMENT TRANSDUCER, high precision.
To be fixed to the high stiffness frame equipped with the square base.
Travel: 50 mm
Full bridge at 350 Ohm
Independent linearity: < 0,1%
Standard sensitivity: 2 mV/V

C090-19

HOLDER for transducer; to be fixed to the high stiffness frame with square base

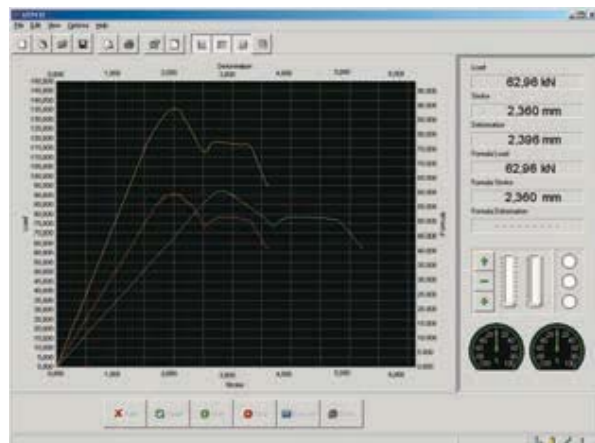

C109-15N Test graph



UNIVERSAL FLEXURAL AND TRANSVERSE MACHINE 150 kN CAPACITY

To perform flexural tests on concrete beam specimens max. size 200x200x800 mm, flat blocks, flagstones, kerbs, tiles, slabs, masonry units, pipes, and any type of material having max. size 550xh550 mm (lower rollers max. length 1325 mm)

STANDARDS: EN 12390-5 / EN 1340:4 / ASTM C78, C293 / AASHTO T97 / BS 1881:118, 6073-1, 7263 / NF P18-407, P98-302
UNE 83305 / UNI 6133 / DIN 51227

section C

TECHNICAL SPECIFICATIONS:

- Vertical daylight between upper/lower rollers: max. 825 - min. 65 mm adjustable each 76 mm by hand winch with counterweights
- Rollers dimensions: dia. 40x613 mm
- Complete with 4 adjustable and articulated rollers for two point loading
- Distance between lower rollers adjustable from 75 to 1325 mm
- Distance between upper rollers adjustable from 75 to 575 mm
- Possibility to easily place in the centre one upper roller for centre point loading
- Graduated scales are foreseen to get easy roller's adjustment
- Ram travel 110 mm approx.
- Simple action piston with counterweights to optimize frictions
- Power supply: 230V 1 ph 50 Hz 750 W
- Dimensions: 970x1400x2000 mm
- Weight: 800÷850 kg



C093-02N + C127N



C093-03N + C127N + H009-01

UNIVERSAL FLEXURAL 150 kN capacity

Model	Motorized	LOAD MEASURING SYSTEM			
		Cyber-Plus Evolution mod. C109N (pag. 158)	Servo-Plus Evolution mod. C104N (pag. 158)	Digitec mod. C108N (pag. 155)	Autotec mod. C098N (pag. 155)

C093-02 N	•	•			
C093-03 N	•		•		
C093-02 D	•			•	
C093-03 A	•				•



234

C091-13

UPPER TAMPERS (steel made), for concrete KERBS tests.
The tamper is mounted on a rotating coupling and fixed to the upper part of the machine to apply a flexural strength on three points on the kerb, without any torsional stress.
STANDARD: EN 1340, 1339



C091-13

C093-11

DEVICE for flexural tests on clay blocks for flooring.
STANDARD: UNI 9730-3

C109-16

SOFTWARE for flexural tests on clay blocks (see pag. 14)

C127N

GRAPHIC PRINTER on thermo-paper on board

C127-11

THERMO-PAPER roll for printer (pack of 10 rolls)

C109-11 SOFTWARE for flexure tests with Digitec and Cyber-Plus Evolution machines. See pag. 14

C123 SOFTWARE "servonet" for remote control through PC of Autotec and Servo-Plus Evolution machines. See pag. 14

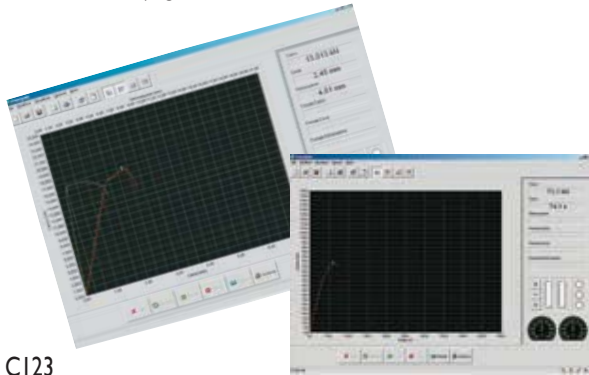

C123 Software "servonet"

C109-11 Software Flexure

C115-01

TWO WAY HYDRAULIC VALVE, connected to the motorized pumping unit of the machine to activate a second frame.
Technical details: see pag. 245



C115-01

C097-01

DUAL LOW CAPACITY DIGITAL RANGE, complete with "appropriate pressure transducer".
Range selectable from 10kN to 100kN
Technical details: see pag. 240

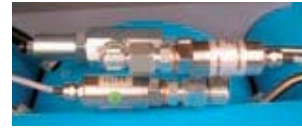

C097-01

C097-05

CLASS 1, starting from 1% of the full range. With a special calibration procedure it is possible to grant Class 1 practically on the full range of the compression machine.

C100

SPLITTING TENSILE test device for cylinders. EN 12390-6 / ASTM C496
Technical details and other models: see pag. 241



C100

C103

SPLITTING TENSILE test device for self blocking pavers and cubes.
EN 1338, 12390-6
Technical details: see pag. 241



C103

C109-12

SOFTWARE for splitting tensile tests.
Technical details: see pag. 14

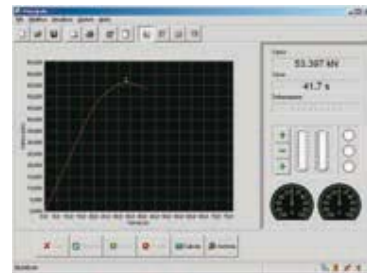

C109-12 Graphic of splitting tensile test

E170

COMPRESSION DEVICE to test cement specimens 40,1 x 40 mm.
EN 196 / ASTM C349
Technical details and other models: see pag. 242

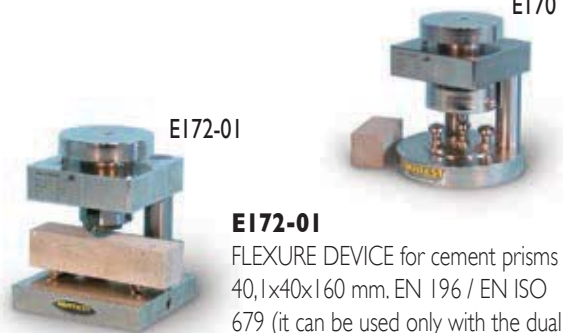

E170

E172-01

E172-01

FLEXURE DEVICE for cement prisms 40,1x40x160 mm. EN 196 / EN ISO 679 (it can be used only with the dual low capacity digital range 0-15kN).
Technical details and other models: see pag. 352



CONCRETE PIPE TESTING MACHINE

Designed and manufactured to test concrete sewer and drain pipes used in drainage works, water and irrigation supply systems etc.
STANDARD: EN 1916 comparable to ASTM C301, C497 / BS 5911 / DIN 4035

The machine is composed of two parts:

- Electro-Hydraulic loading and control system
- Testing frame, steel made

C109-09N

Electro-hydraulic loading and control system, 1 000 kN capacity

- Double action alloy steel ram + cylinder.
- Ram travel: 400 mm
- The ram is ground.
- Upper attachment for steel frame cross-beam coupling.
- Spherical seat fixed to the ram for an uniform loading.
- Hydro-Plus Evolution loading and control cabinet, complete with hydraulic multipiston power pack group, maximum pressure safety valve, decompression valve, oil flow control valve granting smooth and accurate load pace.
- Computerized graphic display "Cyber-Plus Evolution" unit mod. C109N (technical details: see page 158) with software for the acquisition, visualization, processing, printing and saving of the test data and certificates.
- Electric load cell 1000 kN capacity, for accurate load measurement directly from the ram.
- Two flexible high pressure hoses, to connect the cylinder to the hydraulic power pack.

Power supply: 230V 1ph 50Hz 1000W
Dimensions: 500 x 530 xh 1300 mm
Weight: 70 kg

C093-05N

Testing frame, steel made

- Pipe max. diameter (external): 2600 mm
- Pipe min. diameter (external): 450 mm
- Pipe max. length: 2500 mm
- Lower bearers: 2500 mm long
- Upper crossbeam: 2500 mm long
- Frame of structural steel, bolted together with high strength bolts, so it can be easily assembled/disassembled for delivery or for site displacements. The frame has to be locked to a concrete base to be prepared by the customer.
- Two upper crossbeams, raised and lowered by a motor two speed operated winch. The upper frame crossbeam is locked in position by pins inserted through the columns.
- Two lower bearers supporting the pipe to be tested. The bearers are supplied both flat and "V" shaped as requested by the EN 1916 Spec.
- Upper loading beam, floating on a seat.

Power supply of the winch: 230/400V 3ph 50Hz 2000W
Frame dimensions: 3700 x 2500 xh 6900 mm approx.
Weight: 7000 kg approx.

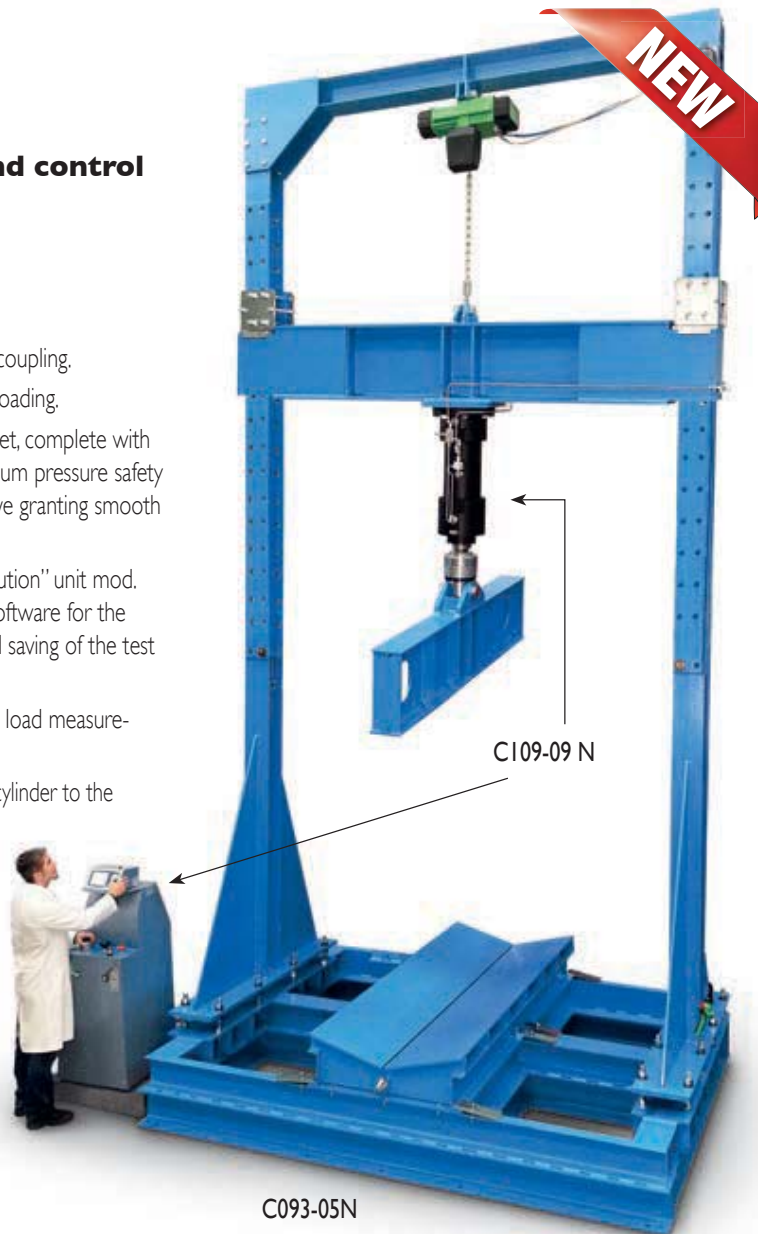

Note:

The testing frame is delivered disassembled and has to be mounted on site following the instructions. The customer can also manufacture locally the testing frame, and purchase the loading/control system only.

Testing frames with different capacity and features can be manufactured as per customer's requirements.

Quoted testing frame cannot be sold in the CE markets.



C109-09N detail





The “Cyber-Plus” and “Servo-Plus” Evolution systems can manage up to “Eight” different frames for compression and flexure tests on: concrete, cement, mortars, blocks, flagstones, kerbs, automatic elastic modulus on concrete, cement and rocks; by using Matest frames, and also existing frames of other producers. Our technical department is at your disposal to solve any specific exigence.



UPGRADING OPTION: COMBINED TWO FRAMES GROUP

All motorized compression testing machines listed in the previous pages can be upgraded with an hydraulic two ways distribution block for connection and control (alternative, and non-simultaneous) to a second frame, like for example flexural frame or cement compression frame, with obvious functional and economic advantages (especially in the digital solutions).

A hydraulic two ways distribution valve may activate the standard frame or the second combined frame by utilizing only one hydraulic pressure source.

The load of the second combined frame is measured:

- For the gauges group with an additional specific gauge fixed on the second frame.
- For the digital group by utilizing one of the channels foreseen on the readout unit connected to the specific pressure transducer fixed on the second frame.

The additional combined frame is supplied complete with a hydraulic two way distribution valve, specific pressure transducer connected to one channel of the digital readout unit (or specific gauge), pipes, connectors, accessories, Matest calibration certificate.

The two frames group can be combined with many different solutions, according to the specific exigences of the customer, with the possibility to perform:

- COMPRESSION TESTS ON CONCRETE CUBE, CYLINDER AND BLOCK SAMPLES, by choosing the standard compression machine among our different available models from 1300kN to 5000kN capacity
- FLEXURAL TESTS ON CONCRETE BEAMS, FLAT BLOCKS, FLAGSTONES, KERBS, SLABS, TILES etc.
- COMPRESSION AND FLEXURE TESTS ON MORTAR SPECIMENS
- SPLITTING TENSILE TESTS ON CYLINDERS, BLOCK PAVERS, CONCRETE CUBES etc.

The composition of the combined group is obtained by:

C092

Flexural frame 150 kN capacity, (technical details and specific accessories at pag. 226) complete with dial gauge, used in conjunction with compression testing machine dial gauge reading.



C055N

C092-01

C092-01

Flexural frame 150 kN capacity, (technical details and specific accessories at pag. 226) complete with pressure transducer, used in conjunction with a digital compression machine (Digitec, Autotec, Cyber-Plus / Servo-Plus Evolution).



C053

C092

C092-11

Flexural open sided frame 150 kN capacity (technical details and specific accessories at pag. 228) complete with pressure transducer, used in conjunction with a digital compression machine (Digitec, Autotec, Cyber-Plus / Servo-Plus Evolution).



C055N + C126

C092-11 + C091-12



C092-15

Flexural high stiffness frame 200 kN

capacity (technical details and specific accessories at pag. 230) complete with pressure transducer; used in conjunction with a digital compression machine (Digitec, Autotec, Cyber-Plus / Servo-Plus Evolution).

This two frames Group offers the considerable advantage to perform compression tests on concrete cube, cylinder and block specimens; flexural tests on concrete beams, and by using suitable accessories, to perform also the following tests:

- Compression on portions of 40.1x40x160 mm mortar broken in flexure conforming to EN 196, DIN 1164 Specifications (Devices mod. E170, E170-01 - see pag. 242)
- Compression on 50 mm mortar cubes, conforming to ASTM C109 (Device mod. E171- see pag. 242)
- Compression on 70 mm mortar cubes, conforming to BS 4550 (Device mod. E171-01 - see pag. 242)
- Splitting tensile on cylindrical specimens dia. 100, 150, 160 mm conforming to EN 12390-6 - NF P18:408 - ASTM C496 - UNI 6135 BS 1881:117 (Device mod. C101-01 - see pag. 241)
- Splitting tensile on concrete cubes and concrete block pavers, conforming to EN 12390-6 , 1338 (Device mod. C103 - see pag. 241)



C055N

C092-15 + C090-12

COMBINED TWO FRAMES GROUP

Upgrading option:

- COMPRESSION TESTS ON CONCRETE CUBE, CYLINDER AND BLOCKS SPECIMENS, BY CHOOSING THE STANDARD COMPRESSION MACHINE AMONG OUR DIFFERENT AVAILABLE MODELS FROM 1300 kN TO 5000 kN CAPACITY
- COMPRESSION AND FLEXURAL TEST ON MORTAR SPECIMENS

The composition of the combined group is obtained by:

C092-05

Compression frame on mortar specimens,

250 kN or 500 kN capacity, ((mod. E159D, E159N, E159-01D, E159-01N, E161A, E161N, E161-02A, E161-02N technical details and specific accessories at pag. 342÷345) complete with pressure transducer used in conjunction with a digital concrete compression machine (Digitec, Autotec, Cyber-Plus / Servo-Plus Evolution).

C092-06

Compression/Flexural frame on mortar specimens, dual range:

0-250 kN (or 500 kN) for compression tests
 0-15 kN for flexure tests (mod. E160N, E160-01N, E161-01N, E161-03N technical details and specific accessories at pag. 346÷349) complete with two pressure transducers used in conjunction with a digital concrete compression machine (only Cyber-Plus / Servo-Plus Evolution).

In addition to the proposed groups, it is possible to compose many other alternative testing groups, with the digital display measuring system, like for ex:

- Group formed by two concrete compression frames.
- Group formed by one concrete flexural frame and one mortar compression frame.



C055N

C092-05 / C092-06



GROUP EXAMPLE

section C



ACCESSORIES TO COMPRESSION AND FLEXURAL TESTING MACHINES

section C



240

C097-01*

Dual low capacity digital range (from 1/3 to 1/20 of the nominal range), complete with **“Appropriate pressure transducer”**, hydraulic installation and cock (solenoid valve with Cyber-Plus and Servo-Plus), fitted on testing machines equipped with digital display measuring unit.

This solution offers very high accuracy also for measurements of low strength, which is necessary to perform compression tests on mortar specimens, flexural tests on concrete beams, split cylinder test on cylinder and cube specimens, tests on kerbs, slabs etc., by utilizing a concrete compression machine.

C097-02*

Dual low capacity digital range 0-300 kN, complete with **“strain gage load cell”**, cables, fitted on concrete compression testing machines equipped with digital display measuring system.

This solution eliminates the weights of the piston and lower compression platen, paking set frictions etc., granting very high accuracy (Class I; max. error within ± 0,5%) in the measuring range 30÷300 kN.

*** NOTE:**

The machines with Cyber-Plus Evolution (C109N) or Servo-Plus Evolution (C104N) system can be equipped of a third measuring scale at the same cost of the second range.

C097-05

Class 1 starting from 1% of the full range. Applicable only to digital machines. By following a special calibration procedure, Matest is capable to grant the Class 1 practically on the full range, upgrading the machine to be used for a considerable number of applications where low strength value are expected, including:

- Lightweight concrete, or early strength concrete
- Small size samples, soil cement mixtures
- Flexural and tensile tests, slabs, kerbs, etc.

C097-08

OFFICIAL ACCREDIA HARDNESS CERTIFICATE

(Equivalent UKAS, ENAC, DAKKS, SAS, COFRAC etc.) of upper and lower compression platens. Minimum hardness: 55 HRC.

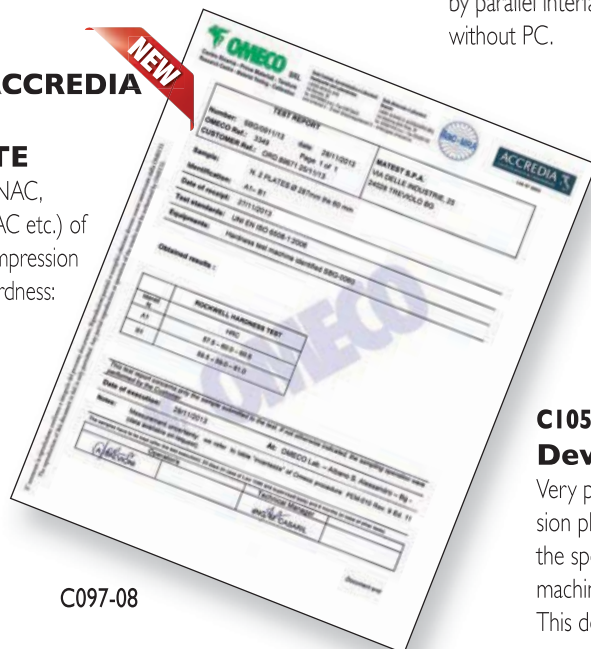

C097-08



C097-01



C097-02



H009-01

H009-01

PERSONAL COMPUTER, complete with LCD monitor; keyboard, mouse, connection cables. It is applicable with all the Matest testing machines equipped with digital display measuring system. The PC supply includes the installation and the setting up of the purchased Software (see pag. 14)

C128

BENCH LASER PRINTER, for the graphic and test certificate printing, applicable on all Matest testing machines with digital display measuring system. The connection is direct by parallel interface also without PC.



C128



C105

C105

Device with central screw

Very practical to adjust the light between the compression platens of a machine, according to the height of the specimen to be tested. Recommended solution for machines equipped with big sized platens.

This device can be foreseen on all models of concrete compression machines, except “High Stability” models.

ACCESSORIES TO COMPRESSION AND FLEXURAL TESTING MACHINES

Splitting tensile test devices

For cylindrical specimens.

STANDARDS: EN 12390-6 / ASTM C496 / NF P18-408
UNI 6135 / BS 1881:117

Model	Cylinders dia. x height mm.	Weight kg	Height mm
C100*	150x300, 160x320, 6"x 12"	20	280
C101*	100x200, 110x220, 4"x 8"	12	220
C102*	40 x 80	1	90



C101-01*

Splitting tensile test device, for cylindrical specimens from dia. 100x200 mm (4"x8") to dia. 160x320 mm (6"x12"). The base is equipped with flat springs centering and keeping in position the specimen.

Two columns with adjustable height sustain the upper plate by two springs.

This item is an alternative solution to mod. C100 + C101

Dimensions: 350x250xh264 mm

Weight: 17 kg



C103*

Splitting tensile test device to perform tests on concrete cube specimens 100 and 150 mm and on concrete block pavers.

STANDARDS: EN 12390-6, EN 1338

Dimensions: 350x250xh264 mm. Weight: 17 kg

* NOTE: To perform the test, these devices have to be used with a concrete compression machine equipped with a low capacity measuring range (see dual low range, pag. 240), or with a flexural frame.



C103-01*

Splitting tensile test device, same to mod. C103

but to perform tests on concrete block pavers having max. dimensions 300 x 500 mm, and for tests on concrete cube specimens 100, 150, 200 mm, and any type of block and prismatic specimens. This splitting device is directly fixed on the compression platens of the block testers having 2000kN or 3000kN capacity.

Weight: 10 kg



C103-02

Splitting tensile device, same to

mod. C103-01, but to be fixed to the flexural frames serie C091-01 (pag. 228) and C090-06 (pag. 230)



ACCESSORIES:

C100-01 STANDARD: EN 12390-6

PACKING STRIPS, dimensions 4x10x350 mm to be used for splitting tensile tests with mod. C100, C101, C101-01, C103.

Pack of 100 pieces.

C100-02 STANDARDS: EN 1338 / BS 1881

PACKING STRIPS, dimensions 4x15x350 mm to be used for splitting tensile tests with mod. C103. Pack of 100 pieces.

C100-03 PACKING STRIPS, dimensions 4x15x540 mm, to be used for splitting tensile tests with the device mod. C103-01.

Pack of 100 pieces

C109-12(N) SOFTWARE UTM2 (Universal Testing Machine 2)



Licence for TENSILE SPLITTING TESTS on cylinders, cubes and concrete blocks.

STANDARDS: EN 12390-6, EN 1338 / UNI 6135

General description and technical details: see UTM2 pag. 14



ACCESSORIES TO COMPRESSION AND FLEXURAL TESTING MACHINES

C106

Flexural device for two point and centre point tests on concrete beams 100x100x400/500 and 150x150x600/750 mm

STANDARDS: EN 12390-5 / UNI 6133 / NF P18-407 / UNE 83305
ASTM C78, C293 / AASHTO T97 / BS 1881:118

Equipped with two lower rollers, one of them articulated, and two upper rollers for third point tests.

- Two fix distances between lower rollers: 300 and 450 mm
- Two fix distances between upper rollers: 100 and 150 mm

It is possible to place in the centre only one upper roller for centre point tests.

To perform the flexural test, this device has to be used with a concrete compression machine foreseen of low capacity measuring range (mod. C097-01, C097-02 pag. 240)

Dimension: 610x200x320 mm. Weight 27 kg

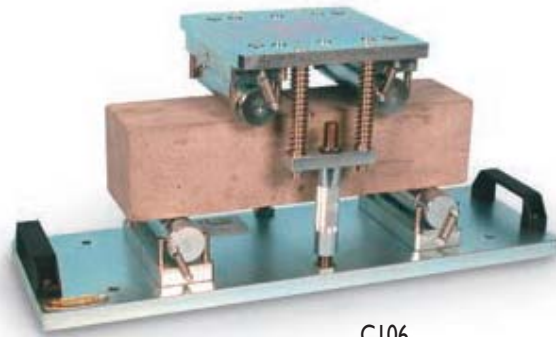

C106

E171-01

Compression device to test mortar cube specimens 70,7 mm

STANDARD: BS 4550

It is possible to test also cylindrical specimens dia. 70x70 mm.

To be used with a concrete compression machine foreseen of low capacity measuring range (mod. C097-01, C097-02) or with a flexural frame.

Weight: 12 kg



E171-01

C091-13

Concrete kerbs and slabs device

FLEXURAL STRENGTH MEASUREMENTS

STANDARD: EN 1340:2004, EN 1339

The equipment consists of a steel tamper mounted on a rotating coupling which is fixed to the upper part of the flexural testing machine (to be selected from serie mod. C090-06, C091 and C093) to apply a flexural strength on three points on the concrete kerb, without any torsional stress.



C091-13

section C



E170

Compression device to test mortar prisms 40,1x40x160 mm broken in flexure

STANDARDS: EN 196-1 / ASTM C349 / NF P15-451

To be used with a concrete compression machine foreseen of low capacity measuring range (mod. C097-01, C097-02) or with a flexural frame.

Dimensions: dia. 153xh182 mm.

Weight: 12 kg



E170

E171

Compression device to test mortar cube specimens 50 mm (2")

STANDARD: ASTM C109

It is possible to test also cylindrical specimens dia. 50x50 mm.

To be used with a concrete compression machine foreseen of low capacity measuring range (mod. C097-01, C097-02) or with a flexural frame.

Weight: 12 kg



E171

ACCESSORIES TO COMPRESSION TESTING MACHINES

Unbonded capping pads and retainers

STANDARD: ASTM C1231

Used for compression tests on concrete cylinder specimens, as an alternative method to the sulphur capping and grinding machine.

Two steel capping retainers are applied on the two flat surfaces of the cylinder:

Two neoprene pads are put between them, for a better load distribution.

The neoprene pads are available in two models:

- 60 shore hardness pads for expected strength from 10 to 48 MPa

- 70 shore hardness pads for expected strength over 48 MPa

The system is not applicable for expected strength lower than 10 Mpa

Models:

C107-09 Capping retainers (couple) for dia. 100x200mm cylinders.

C107-10 Capping retainers (couple) for dia. 150x300mm and 6"x12" cylinders.

C107-12 Capping retainers (couple) for dia. 160x320 mm cylinders.

C107-18 Neoprene pads (couple) 60 shore A for dia. 100x200mm cylinders.

C107-19 Neoprene pads (couple) 70 shore A for dia. 100x200mm cylinders.

C107-20 Neoprene pads (couple) 60 shore A for dia. 150x300mm and 6"x12" cylinders

C107-21 Neoprene pads (couple) 70 shore A for dia. 150x300mm and 6"x12" cylinders

C107-25 Neoprene pads (couple) 60 shore A for dia. 160x320mm cylinders

C107-26 Neoprene pads (couple) 70 shore A for dia. 160x320mm cylinders

C107-29 Neoprene sheet (couple) 60 shore A.
Dimension: 600x400x12mm
For tests on blocks.

Note:

The capping retainers can be used only with compression testers having increased vertical clearance of the testing chamber; respectively to minimum 356 mm for the cylinders dia. 150x300mm or 6"x 12"; and minimum 376 mm for the cylinders dia. 160x320 mm.

C110-30

UPPER COMPRESSION PLATEN + SPHERICAL SEAT, for tests on cylinder specimens dia. 100x200, 150x300, 160x320 mm and 4"x 8", 6"x 12"(to fix on the testing machine, in replacement of the standard one where requested), to meet the ASTM C39, AASHTO T22 Specifications.

Platen dimensions : dia. 165x30 mm

Weight: 10 kg approx.



C110-30



C107-29



EXAMPLE OF UTILIZATION

Auto-centering device

For cubes 100 and 150 mm side and cylinders dia. 100 and 150 mm. The lower compression platen of the testing machine is marked with a serie of concentric circles to facilitate the correct centering of the specimens. However to grant a rapid and accurate centering of concrete cube and cylinder specimens, this "Auto-Centering" device is recommended.

MODELS:

C107

Auto-Centering Device, to be used with compression machine having platen dia. 216 mm (1300, 1500 and 2000 kN)

C107-01

Auto-Centering Device, to be used with compression machine having platen dia. 287 mm (3000 kN and high stability machines)



C107



ACCESSORIES TO COMPRESSION TESTING MACHINES

Safety guards to CE Safety Directive, manufactured from highly resistant transparent polycarbonate material, complete with hinges and lock.

The guards are both on front and back sides.

Fragment guards to CE Safety Directive, manufactured from highly resistant transparent polycarbonate material. The guards are both on front, back and lateral side and are easily/quickly fixed to the machine with hooks.

MODELS:

C119

Machines 1200kN, 1300kN and 1500kN

C119-03

Machines 2000kN (mod C051 to C058-05N)

C119-04

Machines, high stability, 2000kN (mod C089 to C089-04N)

C119-05

Machines 3000kN (mod C066 to C071N) and high stability 3000kN (mod C089-06 to C089-10N)



C121-51

Door stop safety switch

This door locking electric switch if fixed on the front and rear doors of the compression machine as safety device. It cuts off mains and stops the machine when one of the two doors is open. This locking switch can be installed only on digital compression machines equipped with safety guards with hinges and lock to CE Directive, serie C121



C126

Bench, used to hold the compression (or flexural) testing frame, to set the machine at a proper height for its utilization. Alternative solution to a concrete holding base. Made from heavy welded steel, "it can be moved in the laboratory both from front or lateral side by a forklift".

When ordering, please specify the model of testing machine the bench is to be designed.

Weight: 55 kg. approx.



C121



MODELS:

C121

Machines 1200kN, 1300kN and 1500kN

C121-05

Machines 2000kN (mod C051 to C058-05N)

C121-01

Machines with block platens 2000kN (mod C073 to C078N)

C121-06

Machines high stability 2000kN (mod C089 to C089-04N)

C121-10

Machines high stability with block platens 2000kN capacity (mod C089B to C089-22N)

C121-07

Machines 3000kN (mod C066 to C071N) and high stability 3000kN (mod C089-06 to C089-10N)

C121-08

Machines with block platens 3000kN (mod C079-01 to C079-06N) and high stability with block platens 3000kN (C089-15 to C089-19N)

C121-04

Machines 5000kN (mod C086-02 to C086-03N)



C126

ACCESSORIES AND SPARES TO TESTING MACHINES

**C109-03N
Hydro-Plus Evolution**

Stand alone control console. Connected to a load frame, it provides tests throughout all phases: data acquisition, display, processing, saving of the test dates, software for the print out of results and certificate.

To upgrade or complete your concrete or mortar compression and flexure testing machine (even not manufactured by Matest).

The "Hydro-Plus Evolution" control console consists of:

C109N Cyber-Plus Evolution, digital Touch-Screen with 8 analogic inputs (technical data: see pag. 158)

C114 Hydraulic motorized pumping unit with speed selector (technical data: see pag. 153)

Holding frame, complete with hydraulic flexible hose, connector, accessories. Supplied "without" hydraulic oil to be ordered separately (see mod. C114-10).

**C109-04N
Hydro-Plus Evolution for Two Frames**

Similar to mod. C109-03N, but provided with an hydraulic valve, to control alternatively TWO FRAMES.

C113
Pumping unit, hand operated, complete with tank, accessories and connectors. Spare part for compression and flexure machines.
Weight: 20 kg

C114
Pumping unit, motorized, complete with tank, speed selector, hydraulic cock, accessories and connectors. Spare part for compression and flexure machines.
Hydraulic pressure: 0 ÷ 700 Bar
Oil supply from 0,05 to 0,7 litre/min.
Supplied "without" hydraulic oil to be ordered separately (see mod. C114-10).
Power supply: 230V 1ph 50 Hz 750 W
Weight: 40 kg

C114-01
Pumping unit, motorized, identical to mod. C114, but equipped also of a two way hydraulic valve to activate, alternatively, two testing frames.
Supplied complete.

C114-10
SPARE HYDRAULIC OIL for compression/flexural testing machines.
Can of 8,8 kg (2 cans needed).



C109-03N

section C



C115-01
Two-way hydraulic valve, installed on the pumping unit mod. C114, to activate alternatively two testing frames by using the same pumping unit. Complete with protection case.



C115-01 with case



C115-01

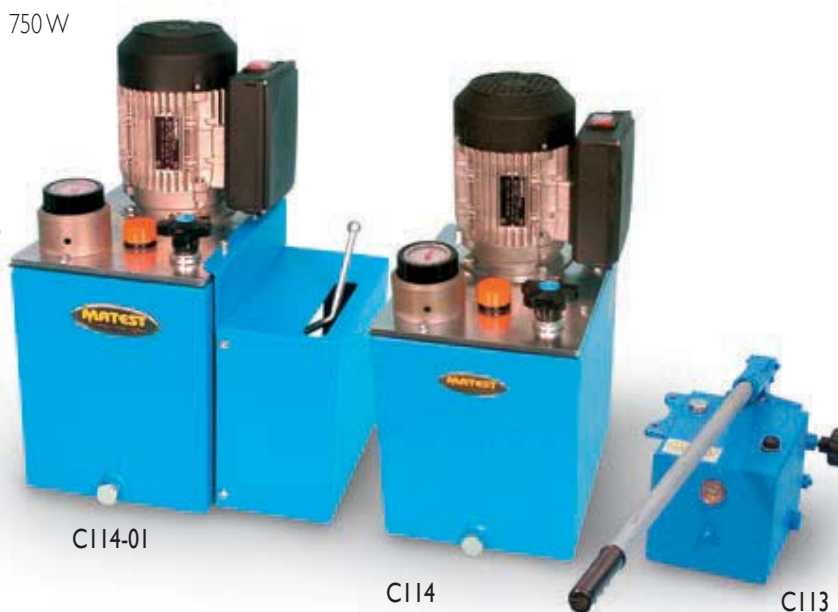

C114-01

C114

C113

SPARE PARTS TO TESTING MACHINES

Gauge, dia. 250 mm foreseen for max. load pointer; zero adjustment and mirror face. Spare part for compression and flexure machines. Supplied pre-calibrated.



C118-05

Pressure transducer

Used in conjunction with digital units Cyber-Plus C109N, Servo-Plus C104N, Digitec C108N, Autotec C098N.
Supplied complete with cable, calibration certificate.
Nominal sensitivity: 2 mV/V. Accuracy: $\pm 0,5\%$

AVAILABLE MODELS:

- C116-01N** Pressure Transducer range: 0 - 10 bar
- C116-02N** Pressure Transducer range: 0 - 20 bar
- C116-03N** Pressure Transducer range: 0 - 35 bar
- C116-04N** Pressure Transducer range: 0 - 50 bar
- C116-05N** Pressure Transducer range: 0 - 100 bar
- C116-06N** Pressure Transducer range: 0 - 200 bar
- C116-07N** Pressure Transducer range: 0 - 350 bar
- C116-08N** Pressure Transducer range: 0 - 500 bar
- C116-09N** Pressure Transducer range: 0 - 700 bar
- C116-10N** Pressure Transducer range: 0 - 400 bar
- C116-11N** Pressure Transducer range: 0 - 600 bar
- C116-12N** Pressure Transducer range: 0 - 160 bar
- C116-13N** Pressure Transducer range: 0 - 60 bar



C116-01N÷C116-13N

Models	Gauge
C118-14	Range 0 - 1300 kN
C118-03	Range 0 - 1500 kN
C118-04	Range 0 - 600 kN for 1300-1500kN machine
C118-05	Range 0 - 2000 kN
C118-06	Range 0 - 600 kN for 2000kN machine
C118-07	Range 0 - 3000 kN
C118-08	Range 0 - 600 kN for 3000kN machine
C118-09	Range 0 - 150 kN for flexure press C090 serie
C118-10	Range 0 - 150 kN for flexure press C091, C093 serie
C118-11	Range 0 - 1500 kN for tensile press H010
C118-12	Range 0 - 300 kN for cement machine
C118-13	Range 0 - 50 kN for cement machine

Packing set, at three elements, for piston/cylinder coupling

MODELS:

- C122** For compression machine 1200 kN capacity
- C122-01** For compression machines 1300-1500 kN capacity
- C122-02** For compression machine 2000 kN capacity
- C122-03** For compression machine 3000 kN capacity
- C122-04** For flexure machine 150 kN capacity, C090 serie
- C122-06** For flexure machine 150kN capacity, C091, C093 serie
- C122-07** For flexure machine 200 kN capacity, C090-06 and C090-07 serie
- C122-05** Packing set for the hand-operated pump of testing machines
- E161-15** For Cement testing machines mod. E151 to E161
- E183-11** For Cement machines mod. E181, E183, piston 250kN
- E183-12** For Cement machines mod. E181, E183, piston 15kN



C122 ÷ E183-12



Compression platens

Surface hardened over 55 HRC and finish-grinding.

UPPER PLATEN:

Model	Dia. mm	Machine
C110	165x30	1200kN
C110-01	216x30	1300kN, 1500kN and 2000kN
C110-02	287x51	3000kN and 2000kN serie C058
C110-03	287x60	2000kN and 3000kN high stability complete with "ball seating"

LOWER PLATEN:

Model	Dia. mm	Machine
C110-11	165x30	1200kN
C110-12	216x30	1300kN, 1500kN and 2000kN
C110-13	287x51	3000kN and 2000kN serie C058
C110-14	287x60	2000kN and 3000kN high stability

C112-10

UPPER and LOWER COMPRESSION PLATENS, complete with "ball seating", dimensions 510x245x55 mm for tests on blocks.

C112-11

UPPER and LOWER COMPRESSION PLATENS, complete with "ball seating", dimensions 510x320x55 mm for tests on blocks.

C112-05

Kit of 4 handles to lift the lower platen, making the positioning of distance pieces easier.

AS AN ALTERNATIVE

C111-50

Distance piece

To be used with compression testers equipped with rectangular platens 510 x 320 mm to test blocks.

This device eliminates the heavy procedure to lift the lower rectangular platen and to add distance pieces to perform compression tests also on cube specimens.

This distance pieces is fixed over the lower rectangular platen through 4 adjustable couplers allowing a quick, correct and stable fixing.

On the distance piece it is now possible to put the round compression platen dia. 216 or 287 mm foreseen by the specific machine.

This distance piece is finish-grinded (suitable also for high stability testers), has dia. 210 mm, height 20 mm.

Weight: 3 kg approx.

Distance pieces

Used to reduce the vertical clearance between the compression platens, according to the height of the specimen to be tested, so to avoid the ram to make its max. excursion (approx. 50-55 mm) without having compressed the specimen.

The distance pieces are placed between the ram and the lower compression platen.

MODELS:

Distance pieces dia. 140 mm for machines: 1200kN, 1300kN, 1500kN, 2000kN (C051 to C056N)

C111-30 High 20 mm

C111-21 High 50 mm

C111-03 High 100 mm

C111 High 176 mm

C111-02 High 226 mm

Distance pieces dia. 200 mm for machines: 2000kN (C058 to C058-05N), 3000kN (C066 to C071N), 2000kN blocks (C073 to C078N), 3000kN blocks (C079-01 to C079-06N)

C111-31 High 20 mm

C111-22 High 50 mm

C111-26 High 76 mm

C111-04 High 126 mm

"Slotted" distance pieces dia. 150 mm for central screw machines: 2000kN (C073 to C078N), 3000kN (C079-01 to C079-06N)

C111-27 High 20 mm

C111-23 High 50 mm

C111-28 High 76 mm

C111-08 High 126 mm

Distance pieces dia. 210 mm, finish-grinding, for "high stability" machines: 2000kN, 3000kN, 2000kN blocks and 3000kN blocks.

C111-32 High 20 mm

C111-24 High 50 mm

C111-25 High 73 mm

C111-16 Distance piece, high 50 mm for flexure machines serie C090

section C



247

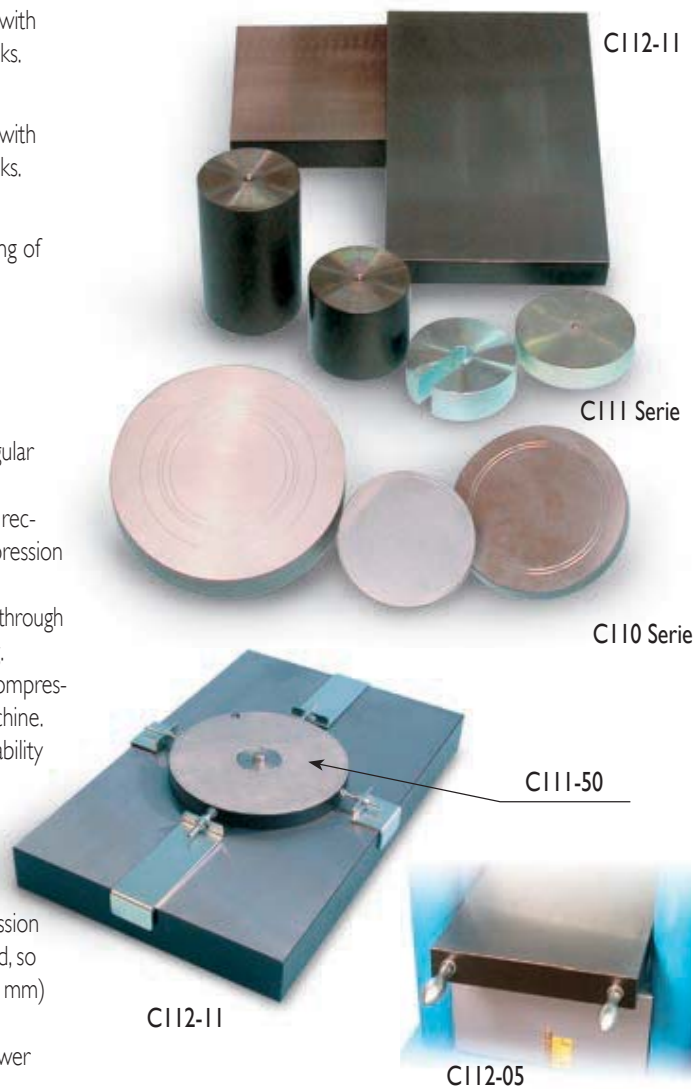

MATEST

S205

UNITRONIC 50 kN, UNIVERSAL MULTIPURPOSE COMPRESSION/FLEXURAL AND TENSILE FRAME FOR:

- COMPRESSION / FLEXURAL TESTS, 50 kN MAX. CAPACITY LOAD WITH AUTOMATIC LOAD OR DISPLACEMENT/DEFORMATION CONTROL, for testing:

Concrete:

- FLEXURE ON BEAMS
- FLEXURE ON TILES

Clay Blocks, Tiles:

- PUNCHING
- TRANSVERSE/DEFORMATION on adhesives for tiles - EN 12002 (see page 416)

Cement, Asphalt, Metal, Wires, Ropes, Plastic, Papers, Textiles, etc.,

Rock and stones, Soil

Unitronic technical details and additional specific tests are described at pag. 414

SPECIFIC APPLICATIONS:

Flexural test with centre point on concrete beams and clay tiles

Standards: EN 12390-5, 491, 538 / ASTM C78, C293
BS 1881:118 / NF P18-407 / UNE 83305 / UNI 6133

Test development with load control.

Needed accessories:

S337-34 Strain gauge load cell, 50 kN capacity

S205-18

Flexure device for centre point loading to test clay tiles and concrete beams dimensions 100x100x400(500) mm
Consisting of lower beam with two bearers (one articulated) adjustable from 100 to 315mm, and upper central articulated bearer fixed to the load cell.

Bearer dimensions: 38 mm dia. by 300mm long. Weight : 20 kg approx.

C109-11 Software for flexure tests on concrete beams

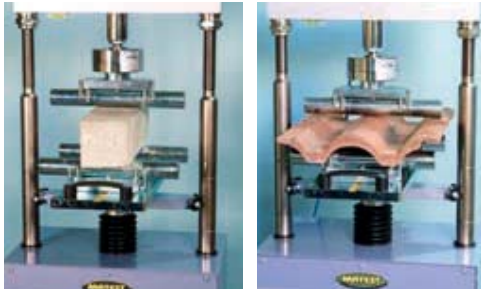

S206N

UNITRONIC 200kN “Matest Made”

Universal multipurpose compression, flexural, tensile frame with automatic load or displacement/deformation control. Technical features: similar to Unitronic 50kN, but with max. capacity: 200kN.

Technical details: see pag. 420

C095-05

Flexure test on clay block portion

STANDARD: UNI 8942-3, 9730-3

The apparatus consists of:

- digital loading balance 16kg capacity x 0,1g sens, with software to display and hold the failure load
- flexure device fitted on the balance, with central rotating knob for load application.

The strip sample is got from one internal wall of the clay block.

The load is obtained by simply rotating the knob that applies a flexural pressure on the strip sample up to the failure.

The balance displays and holds the failure load. Weight: 14 kg approx.



C095-05



S205 with load cell

Punching test on clay blocks

Standard: UNI 9730-3

Test development with load control.

Needed accessories:

S337-32 Strain gauge load cell 10 kN capacity.

C093-11 Flexural punching device.

S205-15 Holding beam for the punching device



S206N



C094N

Portable digital press 56 kN capacity

Used for compression tests on small cylinder specimens and core samples up to dia. 60x100 mm.

The load is applied by a hand pump, and is measured by a high precision electric load cell with a digital display unit range 0-56 kN providing:

- 65.000 divisions
- 0,001 kN resolution
- Linearity: 0,05%
- Hysteresis: 0,03%
- Repeatability: 0,02%

The compression platens have dia. 65 mm., the upper one has a spherical seat and the vertical daylight is 110 mm.

Complete with wooden carrying case, accessories.

Dimensions 370x320x710 mm.

Weight 25 kg



C094N

ACCESSORY FOR C094:

A125-01

Set of two hardened conical points, to modify the press mod. C094 into the "Point load tester" (see section aggregates mod. A125 pag. 60), for the rock strength index test.



A125-01

ACCESSORY FOR C095:

C093-11

DEVICE for flexural tests on clay blocks for flooring
STANDARD: UNI 9730-3

It consists of two lower bearers dia. 20x300 mm and upper square wooden pressure punch.

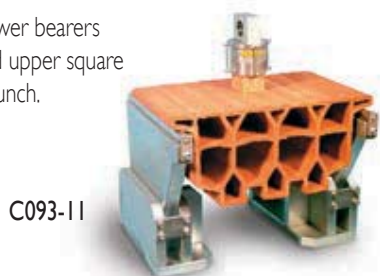

C093-11

C095

Flexural testing machine, 50 kN capacity

DESIGNED TO TEST:

- CONCRETE TILES: EN 491
- CLAY TILES: EN 538
- FLAT BLOCKS: BS 6073:1 app. C.
- HOLLOW TILES: UNI 2107
- CLAY FLOORING BLOCKS: UNI 9730-3
- PAVING SLABS, ROOF TILES, FLOOR TILES, TERRAZZO TILES, CERAMICS, BRICKS, etc.

The machine consists of: steel frame, one upper bearer and two lower adjustable bearers, mechanical hand-operated screw jack and a 10 kN capacity proving ring to measure the applied load.



C095

TECHNICAL DETAILS:

- Proving ring 10 kN capacity, complete with calibration certificate (proving rings with larger capacities up to 50 kN on request - pag. 464)
- Vertical clearance between the bearers, adjustable from 50 to 300 mm.
- Distance between lower bearers, adjustable from 50 to 500 mm.
- Bearers dimensions: dia. 25x500 mm
- Accuracy: 1% of the applied load
- Dimensions: 710x610x1520 mm
- Weight: 120 kg

C096

Impact failure test on tiles and paving materials

STANDARD: Art. 3 n° 2234 - 1939

Utilized to verify the quality of paving materials like tiles, ceramics, bricks, floor tiles etc. by the impact method.

The specimen under test is placed on the base of the device which has been previously filled with sand. Then a spherical ball of approx. 1000 gr. is dropped on the tile from a known height, to measure the height under which the specimen will break.

Dimensions: 810x810x1300 mm

Weight: 70 kg



C096



ABRASION MEASURING BASED ON BÖHME

C129

Abrasion Tester Böhme

STANDARDS: EN 1338 :2004 / EN 1339, 1340, 13892-3 / EN 14157 / DIN 52108



C129

The instrument measures a volume loss in a specimen under abrasion test and it's used in tests such as:

- paving stones
- concrete slabs
- slabs made of natural rocks
- natural stone slabs

The test is performed by positioning a specimen to be verified in a abrasion tester Böhme apparatus on the test track on which has been spread normalized abrasive; the grinding wheel it's made rotate and the specimen submitted to the abrasive load of 294 N for a certain number of cycles.

Before doing a test, establish the specimen's bulk density by measuring weight and thickness.

Perform the test for 16 cycles composed of 22 turn each, calculating at the end a worn as a average loss in volume and weight.

The apparatus is basically composed of:

- cast iron horizontal disc with a speed of 30 rpm and a diameter of 750mm furnished of a 200mm test track to position a specimen.
- Separate control panel with digital revolutions counter with automatic stop after preset revolutions
- Specimen's holder
- Adjustable charger used to produce a force of $294 \text{ N} \pm 3 \text{ N}$ on a specimen

Power supply: 230V 50Hz 1PH 800 W

Dimension: 1500 x 1000 xh 850 mm

Weight: 320 kg

ACCESSORIES:

C129-01

ABRASIVE MATERIAL composed of fused alumina (artificial corundum)
Pack of 25kg.

C129-02

MEASURER THICKER REDUCTION, composed of dial gauge with anular contact face with a diameter of 8.5 mm and measuring board.



C129-02

A113

Skid resistance and friction tester

STANDARDS: EN 1338, EN 1341, 1342, EN 1339

Used for tests on concrete block pavers, natural stones, and skidding tests on wooden floor.

Technical details: see pag. 53



A113

ACCESSORIES:

A110-II Metal base plate.

A110-13 Clamping device for tests on concrete block pavers (EN 1338); natural stones (EN 1341, 1342); skidding tests on wooden floor (EN 1339).



VERIFICATION OF FORCE TRANSFER

STANDARDS: EN 12390-4 / BS 1881:115 / DIN 51302

The equipment to perform this test is composed by:

C155N

**Digital measuring tester
Cyber Plus Evolution “Touch-Screen”**



This unit reads simultaneously the four values supplied by the electric strain load cell. The values are memorized, automatically elaborated and visualized, to directly supply the various coefficients resulting by the calculations, and printed on laser printer (accessory C128) directly connected via USB to the tester.

The unit, through the wide display, shows to the utilizer the different test procedures, as requested by previously selected specification (EN, BS, DIN).

At the end of the test, the display automatically visualizes the test results, by informing also if the frame under test is conforming to the requirements of the selected specification as regards the stability (axial transmission of the loads, self-alignment of the seat ball etc.).

The digital readout unit is also foreseen of a fifth digital reading channel allowing to perform load calibration tests on compression machines up to 3000 kN capacity.

Supplied complete with kit of 5 cables and connectors for load cell coupling, accessories, carrying case.

Power supply: 230V 1ph 50 Hz

Dimensions: 450x350x160 mm

Weight: 8 kg

C155-05

Calibration process of the load cell to the digital tester, complete with Matest calibration certificate.

ACCESSORY (recommended):

C155-10N

Software

To download to PC the results with possibility of certificate printout.

Supplied on CD Rom for PC installation.



C154

Electric strain load cell 3000 kN capacity

Consisting of a strain steel cylinder where four balanced strain gauge bridges are centered to measure the deformation on 4 generatrix in relation with two diameters, orthogonal between them, so that both axial and circumferential deformations can be measured.

The cell incorporates a fifth strain gauge utilized for load measurement calibration tests.

Supplied complete with connectors, cables, calibration certificate.

Dimensions: dia. 130 by 200 mm high. Weight: 18 kg

C154-01

Positioning device, manufactured with special steel, hardened and rectified.

It allows to correctly position the load cell on the lower platen of the compression frame, to carry out the footemeter test as described by the Standards.

Dimensions: 150x150x50 mm

MATEST										
VERIFICAZIONE following BS 1881										
Machine Type	C 089/17				Footemeter	C155 Matest				
Serial No.	1 ord. Exp. 5.355				Verified on	05/01/11				
Plane / date	Treviglio 10/04/11				Load cell	C/PA 3000 kN				
Resolution	0.2 Class 1				Verified on	09/02/11				
Range from	0 to 2000 kN				Temperature	21.0 C				
UPPER PLATE SELF-ALIGNMENT CHECK Load 200 kN										
Lean	e1	e1	e2	e2	e3	e3	e4	e4	avg	
A	0.332	-0.578	0.250	0.071	0.185	-0.032	0.190	0.028	0.187	
C	0.182	-0.008	0.188	0.003	0.188	0.004	0.188	0.001	0.187	
B	0.173	-0.070	0.198	0.045	0.181	-0.031	0.193	0.036	0.186	
D	0.184	-0.031	0.191	0.025	0.190	0.045	0.179	-0.039	0.187	
Max-Min	0.0450 OK		0.0483 OK		0.0708 OK		0.0752 OK			
Avg.	-0.0444 OK		0.0408 OK		0.0014 OK		0.0042 OK			
SELF-LOCKING CHECK Load 300 kN										
Pos.	e1	e1	e2	e2	e3	e3	e4	e4	avg	
A	0.138	-0.261	0.235	0.259	0.187	---	0.188	---	0.187	
C	0.141	0.289	0.133	-0.290	0.189	---	0.185	---	0.187	
B	0.173	---	0.190	---	0.183	-0.225	0.232	0.256	0.185	
D	0.188	---	0.184	---	0.237	0.270	0.138	-0.261	0.187	
ΔAC	0.044 OK		0.042 OK							
SELF-LOCKING CHECK Load 2500 kN										
Pos.	e1	e1	e2	e2	e3	e3	e4	e4	avg	
A	1.950	-0.170	2.182	0.168	1.903	---	1.937	---	1.906	
C	2.170	0.168	1.954	-0.163	1.987	---	1.950	---	1.906	
B	1.864	---	1.860	---	1.632	-0.136	2.127	0.380	1.866	
D	1.861	---	1.872	---	2.149	0.148	1.995	-0.146	1.906	
ΔAC	0.028 OK		0.024 OK							

CERTIFICATE EXAMPLE

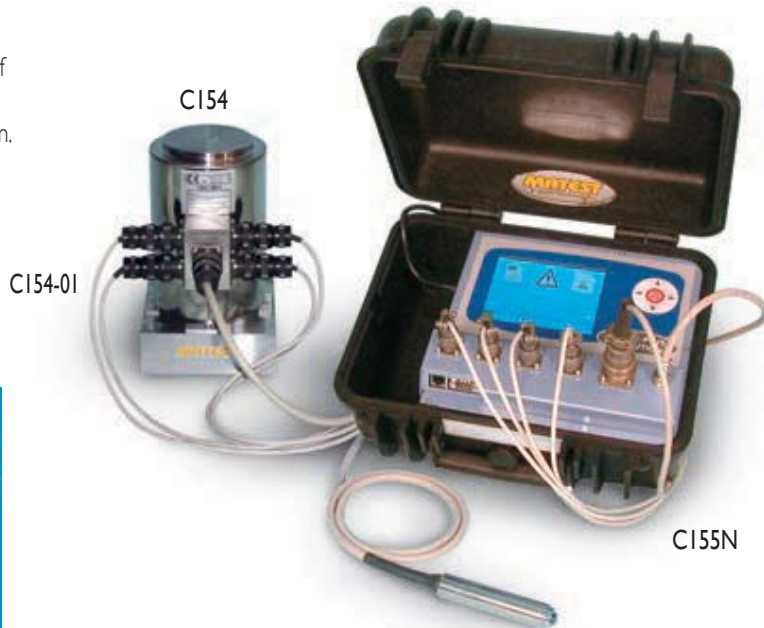

section C



251

MATEST

CI38N

Universal digital tester with microprocessor for load cells

Cyber Plus 8 Evolution "Touch-Screen"

STANDARDS: EN ISO 376:2002 / EN 10002-3

UNI 6326 / DIN 51220 / NF P18-411

ASTM E74 / BS 1610



CI38N

CI40-01

section C



252

This user friendly menu driven digital display, connected to load cells (mod. CI40 to CI40-10 and mod. CI42 to CI42-08) allows to perform an accuracy's verification of the loads measured from machines under control and it allows to produce the relative certificate.

The instrument foresees three memorized cycle verification program composed of ten measurement each.

At the end of the test the unit automatically elaborates the stored value and displays:

- Effective applied load
- Measured load (over three verification cycles)
- Average measured load
- Accuracy in %
- Repeatability
- Relative readability
- Max error

The tester's accuracy is $\pm 0.5\%$ of the indicated load.

TECHNICAL SPECIFICATIONS:

- **HARDWARE:**
 - High resolution converter up to 24 bit.
 - Excitation at 5Vcc
 - Standard signals: feed + feed - (0V) signal + signal - and shield
 - Remote push button to facilitate the readings' confirmation during the calibration and the execution of the cycle of verification.
- **FIRMWARE:**
 - Software administration up to ten load cells. It can be used one cell at a time, selectable among with the ones correctly configured and installed
 - Load measuring range: kN, kg, lb
 - Visualization up to 5 decimal points
 - Date of test and/or calibration
 - Linearization steps or polynomial
 - Digital filter of the first programmable order that is able to filter and settle the value acquired by the electrical cell.

• FUNCTIONS:

- Unlimited execution of verification tests
- Code of the device under verification
- Execution of the verification cycles according to the European EN Standards
- Calculation of all the fundamental parameters required: repeatability and accuracy percentage error, residual error on the 0 point, maximum relative resolution and class of the device under verification
- Sending all the data tests to PC, importable in excel
- Direct USB printer connection (PCL compatible printers)
- Administration of tests by Matcal software (accessory).

• MAIN PAGE:

- Visualization of all the device data of the selected cell
- Date and time
- Available languages: Italian, English, French, German and Spanish, Polish (other languages on request).

• SOFTWARE:

- To download to PC the results (accessory CI155-10N).

Hardware technical details: see pag. 24

The apparatus, and all the accessories, is contained in a strong and practical suitcase, immersion resistant with a depressurisation valve.

Power supply: 230V 1ph 50/60 Hz

Dimensions: 360x300x200 mm

Weight: 5 kg

C138-05

Calibration process of one load cell to the digital tester, complete with Matest calibration certificate.

EN ISO 376
EN 10002-3 Class 2

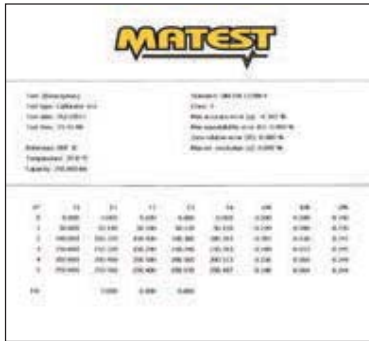

ACCESSORY
(recommended):

C155-10N

Software

To download to PC the results with possibility of certificate printout.

CERTIFICATE EXAMPLE
WITH C155-10N
SOFTWARE

Standard load cells

TO BE USED WITH THE C138N DIGITAL INDICATOR FOR CALIBRATION OF TESTING MACHINES

STANDARDS: EN ISO 376 / EN 10002-3 Class 2 / ASTM E74 Class A

These load cells are suitable for the calibration of compression testing machines. They consist of a high quality steel block, named sensitive element, where some strains have been fitted: the whole is housed in a stainless steel sheathing. While the load is applied, strains are transmitted to an amplifier (mod C138N) which gives a load digital reading. Further advantages is the possibility to equip different load cells on the same measuring tester and therefore to check all load capacities. Supplied complete with Matest calibration certificate. (accessory C138-05).

Model	Capacity kN	Dimensions dia. x height mm.
C140	25	82x59
C140-01	50	82x59
C140-02	75	82x59
C140-03	100	82x59
C140-04	300	135x160
C140-05	600	135x160
C140-06	1000	135x200
C140-07	2000	135x200
C140-08	3000	135x200
C140-09	5000	180x200
C140-10	500	for tensile tests

TECHNICAL SPECIFICATIONS

- Full Scale nominal output: 2 mV/V
- Linearity + Hysteresis: +/- 0,3% of full scale
- Repeatability: +/- 0,03% of full scale
- CLASS: A



C140 + C142-07

C140-12 Device for the tensile load cell C140-10

SCREEN EXAMPLES:

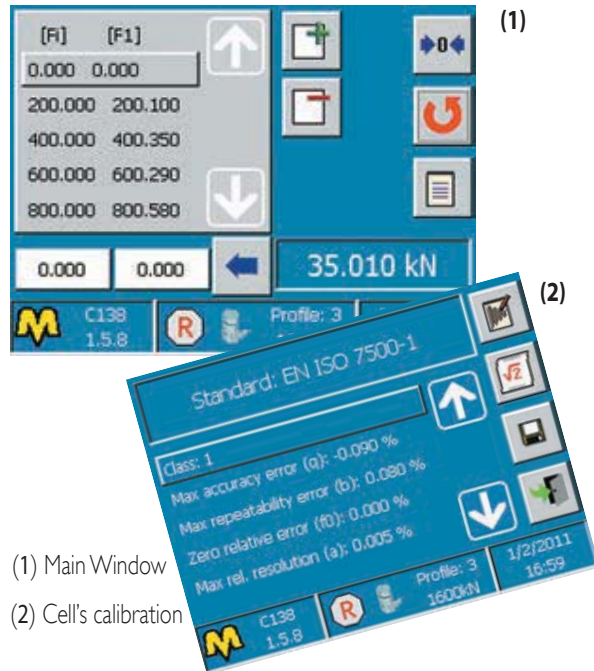

(1) Main Window

(2) Cell's calibration

Strain load cells “high performance”

TO BE USED WITH THE C138N DIGITAL INDICATOR FOR CALIBRATION OF TESTING MACHINES

STANDARDS: EN ISO 376 / EN 10002-3, Class 1 / ASTM E74 Class AA

These electrical strain gauge load cells of high accuracy and stability, are proposed as an alternative to the standard load cells, for verification and calibrations of high precision, repeatability, and are recommended for a professional use, Metrologic Laboratories, SIT centres. To be used with the Digital Indicator mod. C138N. Each cell is supplied complete with Matest calibration certificate (accessory C138-05).

Model	Capacity kN	Dimensions dia. x height mm.
C142	30	100x127
C142-01	100	105x160
C142-02	300	140x160
C142-03	600	140x160
C142-04	1000	150x200
C142-05	2000	135x200
C142-06	3000	135x200
C142-07	5000	135x200
C142-08	600	tensile / compression

TECHNICAL SPECIFICATIONS

- Full Scale nominal output: 2 mV/V
- Linearity + Hysteresis: +/- 0,1% of full scale
- Repeatability: +/- 0,03% of full scale
- CLASS: AA

C138-11 to C138-14

CALIBRATION CERTIFICATE, issued by an Official Calibration Institute (SIT Centre) for one load cell connected to the digital tester mod. C138N

section C



TURBO FORCED MIXERS, PAN TYPE WITH VERTICAL AXIS

STANDARD: EN 12390-2

Used to prepare concrete specimens or mixtures, these mixers ensure an uniform, efficient and fast mixture action. They are of easy and practical utilisation, absorb fewer air during mixing and are suitable for laboratory and field purposes.

Technical specifications:

- Parallel shaft gearbox (mod. C163, C165)
- Oil bath epicycloidal gearbox (mod. C164, C164-01)
- Wear-resistant steel pan (mod. C163, C165)
- Pan and main parts in wearproof steel (mod. C164, C164-01)
- Safety grid with bag breaker
- Adjustable mixing blades
- Manual discharge mouth on the bottom
- Wheels + tow bar (mod. C163, C165)
- Axle with tire wheels and drive drawbar (mod. C164, C164-01)
- Electric control with magnetothermal overload cutout
- Power supply: 230V 1ph 50Hz (mod C165, C163SP)
- Power supply: 400V 3ph 50Hz (mod C163, C164, C164-01)



C164

section C



Models		C165	C163/C163SP	C164	C164-01
Pan capacity (volume)	Litres	100	150	200	300
Yeld per mixture	Litres	65	80	130	220
Pan dimensions (dia x h)	cm	70x30	70x43	80x40	110x40
Motor power	KW	1,1	1,8	4	5,5
Dimensions (dia x h)	cm	71x115	71x150	110x115	130x135
Weight	kg	115	130	250	420



C163

C165

C162

Pan type mixer 56 litres capacity

STANDARD: EN 12390-2

This multiframe mixer absorbs fewer air during mixing, requires shorter mixing time and grants a perfect homogeneity in mixtures having a low water cement ratio.

The pan is easily removable by means of a trolley (accessory).

The blades are hardened against wear.

Mixing pan: 640 mm. dia. x 330 mm deep

Not sellable in CE markets without security cabinet

(see mod. C162-02)

Power supply: 230V 1ph 50 Hz 2 Hp

Weight: 250 kg



C162

C162-01

ACCESSORIES FOR MOD. C162:

C162-01 TROLLEY for fast and easy removal of the mixing pan of the multi-flow mixer

C162-02 SECURITY CABINET, manufactured from steel sheet, conforming to CE Safety Directive.



C161

C161

Drum type mixer

Suitable for field mixes of low/medium strength concrete.

Drum volume: 130 litres

Yield: 75 litres of concrete

Power supply: 230V 1ph 50/60Hz - 0,3 HP

Dimensions: 720x1320x1280 mm

Weight: 60 kg

section C



255

MATEST

Testing fresh SELF COMPACTING CONCRETE (S C C)

ERMCO/EFNARC European Guidelines.

Free Flow and Time Flow determination. “Spray-Test”

STANDARDS: EN 12350-8 / SCC / ERMCO-EFNARC
UNI 11041 / RILEM report N. 23

To evaluate the deformability of fresh concrete through free flow, and the time needed to spread a 500 mm diameter.

Applicable to concrete with aggregates of 25 mm max. size

C181 SLUMP CONE, galvanized steel, to EN 12350-2 Spec.

C170-01 PLATE, galvanized steel made, dimensions 905 x 905 mm, with engraved two circles having 210 and 500 mm diameter and central X cross.

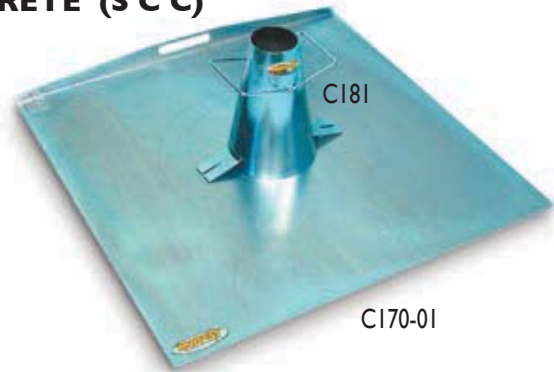

section C



256

Flow time determination. “V-funnel test”

STANDARDS: EN 12350-9 / SCC / ERMCO-EFNARC
RILEM report N. 23 / comparable to UNI 11042

To evaluate the segregation resistance of self-compacting freshly mixed concrete through the flowing speed from a funnel.

Applicable to concrete with aggregates of 25 mm max. size.

C171

V-FUNNEL, “stainless steel” made, stand mounted. The upper edge of the funnel is smooth and reinforced, and the outflow orifice is equipped of an openable seal valve.

Dimensions: 640 x 340 x 1050 mm. Weight : 20 kg approx.

V127 BOX, polythene made, to collect the concrete.

C171-II Filling hopper stainless steel made, to pour the concrete into the funnel in one operation, as specified by the Standard.

C262 Straight edge, 460 mm, to level the concrete.

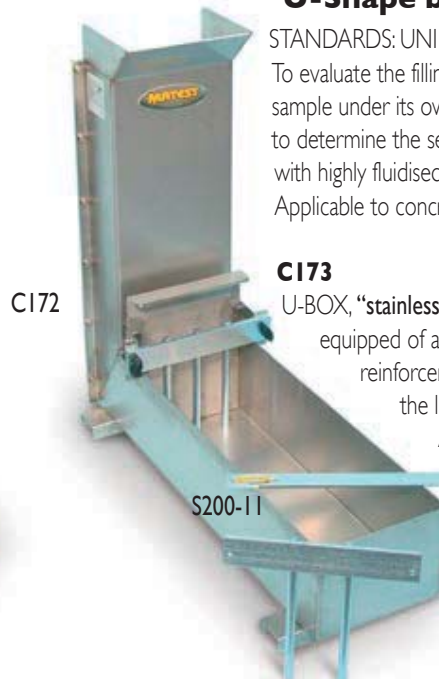

Confined flowability determination. “L-Shape box”

STANDARDS: EN 12350-10 / SCC / ERMCO-EFNARC
RILEM report N. 23 / comparable to UNI 11043

To determine the confined flowability of self-compacting freshly mixed concrete, and to evaluate the filling and passing ability and segregation resistance.

Applicable to concrete with aggregates of 25 mm max. size.

C172

L-BOX, “stainless steel” made, consisting of:

- container with inside rigid surfaces,
- obstacle of two different interchangeable set of grids:
- one set of 3 vertical bars having dia. 12 mm and free light of 41 mm
- one set of 2 vertical bars having dia. 12 mm and free light of 59 mm
- gate in guillotine form

Dimensions: 712 x 280 x 682 mm

Weight : 40 kg approx.

S200-II STRAIGHT EDGE, 300 mm long, galvanized steel, to level the concrete.

Confined flowability determination. “U-Shape box”

STANDARDS: UNI 11044 / RILEM report N. 23

To evaluate the filling speed and height of the concrete sample under its own self-weight, in the U-shape filling box, to determine the self-compactability. The test is performed with highly fluidised fresh concrete with superplasticiser.

Applicable to concrete with aggregates of 25 mm max. size.

C173

U-BOX, “stainless steel” made, with inside smooth walls, equipped of a flow obstacle formed by four vertical reinforcement bars. The bars have dia. 10 mm and the light between them is 35 mm.

A gate in guillotine form splits the vertical portion of the box from the horizontal one.

Dimensions: 480 x 250 x 680 mm

Weight : 20 kg approx.

S200-II

STRAIGHT EDGE, 300 mm long, galvanized steel, to level the concrete.

**Confined flowability determination.
“J-Ring apparatus”**

STANDARDS: EN 12350-12 / comparable to: UNI 11045 / ASTM C1621

To determine the flowability, i.e. the flow time and the capability of the self compacting concrete to pass through obstacles.

C174 N

J-RING APPARATUS, galvanized steel made, having rectangular section 30 x 15 mm and median diameter of 300 mm.

The median circumference of the ring is drilled, and n. 16 cylindrical bars dia. 18 x 140 mm are fixed into the holes.

The bars have a close distance of 41 mm between them, to simulate a condition of higher density of the reinforced bars.

C174-01N J-RING APPARATUS, similar to C174N, but having n° 12 cylindrical bars and 59 mm distance between them, to simulate a condition of standard density of the reinforced bars.

C170

SLUMP CONE, galvanized steel, conforming to EN 12350-2 Spec.

C170-01

PLATE, galvanized steel made, dimensions 905 x 905 mm, with engraved two circles having 210 and 500 mm diameter and central X cross.

C183

Vebé consistometer

STANDARDS: EN 12350-3 / BS 1881:104 / UNI 9419

The Vebé consistometer method is based on the same principle of the simple slump cone test method, for the determination of the workability of concrete, but it has the advantage of a mechanized action. After removing the slump cone, the concrete undergoes a vibration to determine its slump.

Supplied complete.

Power supply:

230V 1ph 50 Hz 250 W

Dimensions:

260x380x700 mm.

Weight: 90 kg



C183



C173

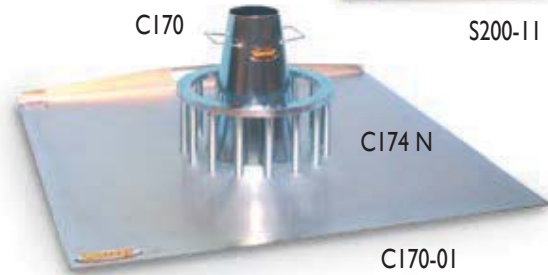

C170

S200-11

C174 N

C170-01

C184

Vibrating table

(Vebé consistometer)

STANDARD: ASTM C1170-92

For determining the consistency and density of roller-compacted concrete.

Similar to mod. C183, but conforming

to ASTM C1170-92 Spec. with

sliding weight of 50 lbs

* Power Supply:

230V 1F 50 Hz 180 W

Dimensions: 280x400x900mm

Weight: 110 kg

* NOTE: The vibrating table is available also at:
230V 60Hz and 110V 60Hz



C184

ACCESSORY for the C184 table:

C184-10

SLIDING WEIGHT 20 LBS (that replaces the standard 50 lbs one) + base to fix a cylinder mould dia. 6"x12" (optional mod. C258-03) to conform the Vibrating Table to the ASTM C1176-92 Specifications.

C258-03

C184-10



SLUMP CONE TEST SETS

STANDARDS: EN 12350-2 / EN 12350-8:2011 / ASTM C143 / BS 1881:102 / AASHTO T 119
NF P18-305 / UNE 7103 / UNI 9418

SLUMP CONE COMPLETE TEST SETS. Matest proposes different versions:

C180-KIT SLUMP CONE, COMPLETE SET, ideal for laboratory tests including:

- C180-01** Slump Cone, "stainless steel" made
- C180-02** Tamping rod, galvanized steel, dia. 16 x 600 mm
- C180-03** Slump Cone funnel, galvanized steel
- C180-06** Graduated slump scale "engraved in 0,5 cm" increments with sliding measuring rod
- C180-07** Base, galvanized steel, complete
- V184** Aluminium scoop, 500 cc capacity
- V178-01** Fine wire brush

Weight: 10 kg approx.



section C

258



C178-KIT PORTABLE SLUMP CONE TEST SET, including:

- C181** Slump Cone, "galvanized steel"
- C179-02** "Graduated" steel tamping rod, galvanized, Ø16 x 600 mm
- C179-01** Base, manufactured from heavy duty galvanized steel, complete with clamps and measuring bridge which is also used as carrying handle.

The slump is measured using the tamping rod having a graduated scale engraved in 1 cm increments. The components of the set are fitted together for easy carrying.

Very practical, robust, ideal for site use.

Weight: 8 kg approx.

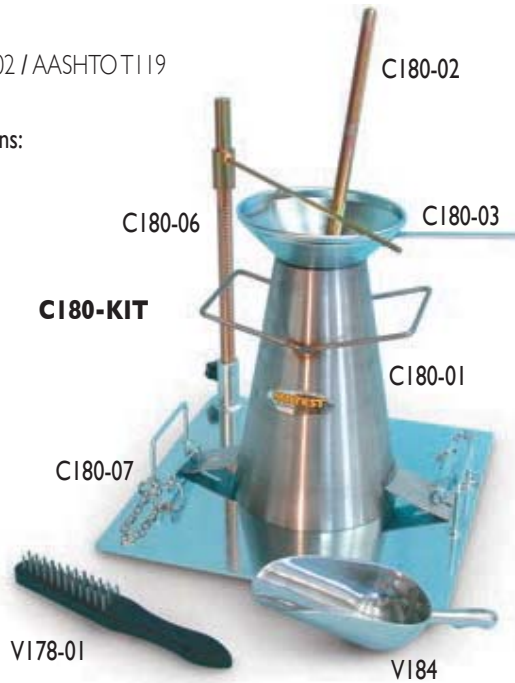

C182-KIT SLUMP CONE, COMPLETE SET, including:

- C181** Slump Cone, "galvanized steel"
- C180-02** Tamping rod, galvanized steel, dia. 16 x 600 mm
- C180-04** Base plate, galvanized steel
- V176-01** Stainless steel rule, 300 mm long
- V184** Aluminium scoop, 500 cc capacity
- V178-01** Fine wire brush

Weight: 5 kg approx.



C179-KIT PORTABLE SLUMP CONE TEST SET, including:

- C180-01** Slump Cone, "stainless steel" made
- C179-02** "Graduated" steel tamping rod, galvanized, Ø16 x 600 mm
- C179-01** Base, galvanized steel, complete with clamps and measuring bridge, as described above.

Weight: 8 kg approx.



C179-02 DETAIL

NOTE:

Each component of the kits can be ordered separately. The user can personalize the kit composition for the Slump Cone test.

C182P KIT

Slump Cone, Plastic, complete set including:

- C181P** Slump Cone, "plastic". Weight: 750 g
- C180-02** Tamping rod, galvanized steel, dia. 16 x 600 mm
- C180-04** Base plate, galvanized steel
- VI76-01** Stainless steel rule, 300 mm long
- VI84** Aluminium scoop, 500 cc capacity
- VI78-01** Fine wire brush

Weight: 5 kg approx.

ACCESSORY:

- C180-03P** Cone Filling Funnel, "plastic". Weight: 250 g

Note: Each component of this kit can be ordered separately.



C182P KIT

C180-01

Slump Cone only, manufactured from "stainless steel", diameter 100/200mm, height 300mm, thickness 1,5 mm. Weight: 2 kg approx.

C181

Slump Cone only, galvanized steel, diameter 100/200mm, height 300mm, thickness 1,5 mm. Weight: 2 kg approx.



C180-01

C181

C180-03P

C181P

VI85-03

Scoop, stainless steel

STANDARDS: EN 12350-1 / UNI 9416
BS 1881:101

Used to sample fresh concrete
Capacity: 5 kg of concrete
Dimensions: dia. 125x250 mm



VI85-03

C185

Compacting factor apparatus

STANDARDS: BS 1881:103
BS 5075

Designed to undertake a more precise and sensitive test procedure than the simple slump test. The apparatus consists of two conical hoppers mounted on a cylinder. Each hopper has a hinged flange with quick release mechanism and everything is mounted on a rigid steel stand.

The compacting factor is the ratio between the weight of the partially compacted concrete and the weight of the fully compacted concrete. Supplied complete with tamping rod dia. mm 16x600 long. Dimensions: mm 500x400x1510. Weight: 55 kg



C185

C192 KIT

Flow table

STANDARDS: EN 12350-5 / BS 1881:105 / DIN 1048 / UNI 8020

The apparatus comprises a galvanized steel conical mould, dia. 130/200 xh 200 mm, double steel flow table with galvanized top plane, guide device, wooden tamper. Used to determine the workability of concrete. The top table has a square surface of 700x700 mm, hinged on one side. Weight: 30 kg

SPARES:

- C192-01** Conical mould, galvanized steel made, dia. 130/200 xh 200 mm

- C192-02** Wooden tamper

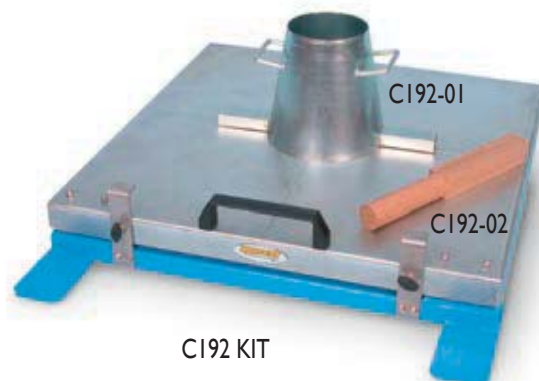

C192 KIT



C187

K-slump tester

STANDARD: ASTM C1362

To determine the degree of compaction and the workability of fresh concrete. Used for in-situ measurements or inside test moulds. Test results can be correlated against the slump values. Weight: 500 g

C187



C188

C188

Walz consistometer

STANDARDS: EN 12350/4 / DIN 1048 / UNI 9420

To measure the consistency of fresh concrete. It consists of a metal box with handles 200x200 mm by height 400 mm, painted for rust protection. Weight: 6 kg

C189

Concrete workability meter

STANDARD: NF P18-452

The concrete workability meter (also known as plastometer) is designed to test concrete for dynamic workability.

It is suitable for field and laboratory tests to check:

- concrete mix for consistency, especially water content
- optimum proportioning of concrete constituents (sand, gravel, water, cement)
- possible improvement when admixing a plastifier
- comparing two concrete types

The unit consists of a prismatic receiver divided into two unequal volumes by a removable partition, and an electric vibrator.

The fresh concrete is poured into the large volume space, the separating partition is removed, and the vibrator starts automatically.

The test consists in measuring the time required for the concrete to reach a uniform distribution in the receivers

Power supply: 230V 1ph 50 Hz 300W

Dimensions: 820x420x410 mm

Weight: 80 kg



C189

C186

Kelly ball apparatus

STANDARD: ASTM C360

Consisting of a hemispherically ended cylinder with guiding frame and a handle graduated in inch, it is used to determine the workability of fresh concrete. The ball is lowered into the concrete and the penetration measured.

It can be used on site or in laboratory.

Cadmium plated for rust protection.

Weight: 15 kg

C186



C190

Plasticity meter

Used for quick and easy measurements of the plasticity of mixtures, especially concrete, and so to detect rapidly any excess of water:

The measuring system is related to the shear strength applied by a three blade head to the mixture under test.

It is possible to measure the plasticity at several different points, and directly in the mixture, with multiple checking, and obtained values can be easily compared with the values got by the slump Abrams cone test.

Dimensions: dia. 130x180 mm

Weight: 2 kg



C190



SETTING TIME OF CONCRETE BY PENETRATION

STANDARDS: ASTM C403 / AASHTO T197 / UNI 7123

C213

Concrete penetrometer

Used to determine the setting time of the mortar fraction in concrete mixes with slump greater than zero, by testing mortar sieved from mix. The apparatus consists of a spring penetrometer (capacity 100 kgf, precision 1 kgf) and six interchangeable stainless steel needle pointers of 16-32-65-160-325-650 mm² area. A sliding ring indicates the reached load on the handle of the penetrometer. Supplied complete with carrying case. Dimensions: 450x160x70 mm. Weight: 5 kg



C213

C194

Concrete pocket penetrometer

Used for the evaluation of the initial set of the concrete mortar. The penetration plunger has a tip area of 32 sq/mm. It is plunged into the mortar to a depth of 25,4 mm, indicated on the plunger. The resistance expressed in Kpa and Lbf/sq.in. is shown on the marked direct-reading scale. Dimensions: dia. 25x210 mm. Weight 400 g



C194

C194-01

Concrete pocket dial penetrometer

To evaluate the initial set of concrete, and the effect of the retarders in the setting time. The plunger has dia. 1/4" (32,3 sq.mm.); the dial has dual scale: 0-700 p.s.i. and 0-50 kg/sq.cm. Supplied complete with plastic case. Weight: 300 g approx.



C194-01

C211

Joisel apparatus Ø 140x220 mm high

STANDARD: French LCPC Method

Used to separate the various elements of the fresh concrete such as cement, sand, aggregates. All made from stainless steel. Weight: 2 kg



C211

C220

Water test set for concrete mixing water

STANDARDS: EN 1008 / EN 206 / DIN 4030

This kit, utilized to test the water mixing concrete, is composed by different dropping bottles, water-proof colors scales, test strips. It is suitable, to carry out more than 50 analysis of: total or momentaneous pH, magnesium, ammonium, chloride, sulphate, lime dissolving CO₂, carbonate hardness, total hardness. Contained in carrying cases. Weight: 2 kg



C220

section C



261

MATEST

C195

Air entrainment meter 5 litres capacity, water column type

STANDARDS: EN 12350-7 / BS 1881:106 / UNI 6395
ASTM C231 type A / NF P18-353 / UNE 7141

Made from cast aluminium alloy. It records directly the percentage of air enclosed in freshly mixed concrete by operating according to the air pressure principle.

The instrument is supplied complete with pressure gauge tamping rod and hand pump.

Air content range 0÷8% - div. 0,1%

Dimensions: dia. 250x700 mm. Weight: 13 kg

ACCESSORY:

C195-01 Calibration cylinder to check and calibrate the air meter mod. C195

C196

Air entrainment meter 8 litres capacity, pressure gauge type

STANDARDS: EN 12350-7 / DIN 1048
ASTM C231 type B

It consists of an aluminium vessel with built in hand operated pressure pump, connected to the measuring gauge showing directly the air content in percentage.

Air content range:

0÷10% div. 0,1% up to 8% and 0,5% over

Dimensions: dia. 250x450 mm

Weight: 12 kg



C196

C197

Air entrainment meter 8 litres, electric, pressure gauge type

Identical to mod. C196 but with built in automatic electric air compressor giving air pressure, and keeping it constant all along the test.

Power supply: 230V 1ph 50/60 Hz

Dimensions: dia. mm. 250x450

Weight: 14 kg

ACCESSORY:

C197-01

Filling hopper for the air entrainment meters C196 and C197



C197

C198

Air entrainment meter, 7 litres capacity, pressure gauge type

STANDARDS: EN 12350-7 / ASTM C231 type B / AASHTO T152

It consists of an aluminium cylindrical vessel with airtight cover assembly incorporating an air pump, a precision pressure gauge 90 mm dia. and valves.

Capacity: 7 litres.

Air content range: 0 - 100%

Gauge graduations: 0,1% up to 6% of the scale; 0,2% from 6% to 10% of the scale. Lightweight, compact and durable, this meter

allows quick clamping system and testing with few pump strokes. It is not affected by change in atmospheric pressures. The container can be used also for unit weight measures of fresh concrete and aggregates. Supplied complete with calibration kit, accessories, robust plastic carrying case.

Dimensions: dia. 250 by 500 mm approx. Weight: 10 kg



C198



C195

C195-01

DENSITY OF FRESH CONCRETE

**C199
Unit weight
measure,
10 litres capacity**

STANDARDS: EN 12350-6
EN 1097-3 / BS 1881:107
ASTM C29, C138

Used to determine the weight per cubic metre of freshly mixed and compacted concrete.
Made from steel, 4 mm thick, with inside radius between wall and base of 20 mm, with machined rim and base.
Inside diameter 200 by height 320 mm
Weight 9 kg



**Admixtures for concrete, mortar and grout.
Determination of bleeding of concrete**

STANDARD: EN 480-4

C199-10

CONTAINER, having 250 mm dia. by 280 mm height, complete with cover:

“Stainless steel manufactured”, it is used for the determination of the relative bleeding of a fresh concrete sample, using aggregates having max. size of 50 mm.

Weight: 5 kg aprox.

ACCESSORY:

C199-11

Tamper, “stainless steel” made, dia. 100 mm

Unit weight measures

STANDARDS: ASTM C29, C138 / AASHTOT19 / UNI 6394
UNE 7286 / BS 812, 1881, comparable to EN 1097-3
Made from heavy steel sheet, they are used to determine the weight per cubic metre of freshly mixed and compacted concrete, and as per ASTM Standards also the air content of fresh concrete.



Models	Capacity Litres	Inside diameter mm	Useful height mm	Sheet thick mm	Weight kg
C200	1	108,3	108,6	3	2
C201	2	108,3	217,1	3	3
C201-01	3	160	149,2	3	3,5
C202	5	187,7	180,7	3	4
C202-01	7	187,7	253	3	5
C203	10	265	181,3	4	7
C204	14	265	253,8	4	9
C204-01	15	265	272	4	12
C205	28	345,6	298,5	5	14
C205-01	30	345,6	319,8	5	15



CONCRETE FLOW TABLE

STANDARD: ASTM C124 / comparable to UNI 8020-A / AASHTO T120 / UNE 7102

Used to determine the flow of concrete. The apparatus consists of a flow table, stainless steel flow mould, tamping bar.



C208



C208 + C208-01

MODELS:

C208 FLOW TABLE

Hand-operated by crank handle.
Table diameter 762 mm.
Weight: 100 kg

C208-01 MOTORIZATION KIT to be connected to the flow table mod. C208 and to get it automatic.
Complete with separate control panel and automatic digital drops counter.
Power Supply: 230V 1ph 50 Hz 750 W
Weight: 15 kg

C214

Cementometer

For the rapid determination of moisture content in wet cement and concrete.
Fast and easy to use; simply insert the prongs into the material being tested,
Accurate and instantaneous readings, digital portable meter.
Ratio range: 0,35 to 0,70 water/cement.
The unit can store over 150 readings.
Data can be recalled via RS-232 interface to using WIN98 and above.
Power: 4AA Batteries
Weight: 2 kg approx.

C214-01

Cementometer

Same to mod. C214 but with ratio range: 0,25 to 0,5 for low water cement ranges

Density of hardened concrete

STANDARDS: EN 12390-7 / BS 812, 1881 :114 / UNI 6394

V085

Specific gravity frame. Technical details: see pag. 472

V085-01

Cradle for holding specimens

V041

Density basket dia. 200 by 200 mm, stainless steel, 3,35 mm mesh size.

Note:

Balances for specific gravity tests: see pag. 470

V072-06



V085



V041



C214

NEW

C303N

Two channels thermometer K-type thermocouple, with Windows software for data download to PC

This model is used to automatically measure and store the temperature of concrete casting during the curing phase. This watertight thermometer is provided with two inputs to connect separately two K-type thermocouple probes. The data read by the probes can be transferred every 2 seconds to a PC by means of the RS232 port and the appropriate cable and software supplied with the equipment.

This advanced thermometer displays the current measure along with the minimum and maximum temperatures recorded by the two probes during the working cycle. These data are displayed on a two-levels backlit display.

The thermometer can also display:

- the difference between the temperature values read by the two probes compared with a reference value;
- the minimum and maximum temperature levels detected by the probes.

The "hold" button allows the operator to fix the measure on the display and write it down easily.

Measuring range: from -149.9 C to 999.9°C

Resolution: 0,1°C Reading: °C e °F

Power: 3 x 1.5V AA / about 500 hours of continuous use (without backlit display); automatic turning off device, that can be selected after 8 or 60 seconds (this function can be disabled).

Using conditions: from -10 to 60°C; U.R. max. 100%

Supplied complete with: 50 meters of K-type thermocouple coil, set of 4 male connectors, RS232 connecting cable, software for data management through PC, carrying case.

Dimensions: about 300x200x80mm

Weight: 800 g

SPARE PARTS:

C303-01 K-type thermocouple coil (50 meters)

C303-11 Set of 4 male connectors

C303SW Software for PC connection

C303-06N Cable for PC connection



C303N



C303N Detail of the 2 probes

C215

RAM - rapid analysis machine

STANDARD: BS 1881:128

Used for the determination of cement content in fresh concrete, coarse and fine aggregate, fly ash and GGBF slag content can also be determined. Fully automatic procedure with quick and accurate test results (max. errors within 5 kg/cubicmetre).

The complete test takes approx. 10 minutes. The connection to water net for approx. 80 litres each test is required.

The weight of the test sample is 8 kg.

Supplied complete.

Power supply: 230V 1ph 50 Hz

Dimensions: 780x660x1500 mm

Weight: 150 kg



C215

section C



265

MATTEST

PLASTIC CUBE, CYLINDER AND BEAM MOULDS

These one-piece moulds, very appreciated by the user, are made from hard plastic, strong, light, undeformable; resistant to vibrations shocks and wear. They do not require mounting and dismounting operations, thus saving time and labour. They just require a simple clean and demould oiling before being ready for use again for many times. The specimen is expelled from the mould by compressed air or water.

The moulds: C223, C224, C230N, C232N, C228, C229 are produced by Matest and have competitive manufacturer prices.

CUBE MOULDS 150 MM SIDE

The cube moulds 150 mm side can be supplied in three different models, each one with different characteristics and weight.

All the 3 models have a reinforced band on the walls, and the inside surfaces are very smoothed getting easier the specimen's ejection.

Models C223 and C224, Matest made, have also "reinforced corners", granting an additional resistance, and foresee a "X" reinforced band on the base, improving the strenght of the mould, and allowing the user to give small blows with a rubber heated hammer (mod.V195) by easing the specimen's ejection. All the moulds are supplied with engraved the logo Matest.

All the moulds are also available unbranded, and on request they can be supplied with engraved the "customer's logo"

MODELS:

C223 "Matest production"

CUBE MOULD, 150 mm side, with "X" reinforced band on the base, and reinforced corners.
Weight: 1300 g approx.

C224 "Matest production"

CUBE MOULD, 150 mm side, "HIGH DENSITY", with "X" reinforced band on the base and reinforced corners. The mould same to mod. C223 is manufactured from "high density mixture" with total weight 1600 g, by obtaining a higher hardness and strength of the plastic material.

- It increases the abrasion resistance, by reducing the wear action.
 - It improves the pressure resistance during the specimen's ejection, by reducing mould breakages.
 - It ensures a larger number of utilisations (with the same use care).
- Weight: 1600 g approx.

Detail of the "X" reinforced band on the base of C223, C224, C232N, C235, C237, C238 models

Reinforced corners



C223 / C224

C232N "Matest production"

CUBE MOULD, 100 mm side, TWO GANGS, with "X" reinforced band on the base. The inside surfaces are very smoothed getting easier the specimen's ejection.
Weight: 1050 g approx.

C232

CUBE MOULD, 100 mm side, TWO GANGS, with reinforced corners and band on the walls.
Weight: 1200 g approx.

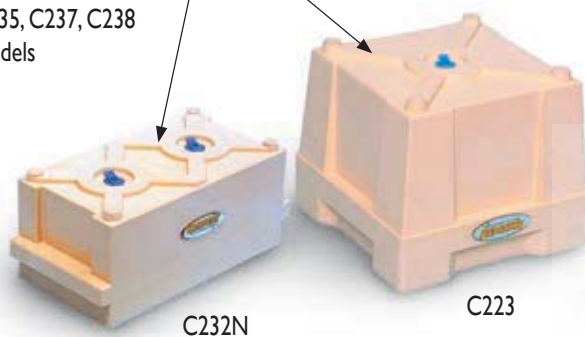

C232N

C223



C232

C232N

C230N

"Matest production"

CUBE MOULD, standard, reinforced band, 150 mm side
Weight: 1250 g approx



C230N

C230-03



C230-01

C230

C230

CUBE MOULD, standard, reinforced band, 150 mm side
Weight: 1260 g approx



C235

CUBE MOULD, 200 mm side, with "X" reinforced band on the base and upper double reinforced walls and corners. Weight: 2550 g approx.

C235



C238

C237

C237

BEAM MOULD, 100x100x500 mm sides, with "X" reinforced bands on the base and upper double reinforced walls and corners. Weight: 2100 g approx.

C238

BEAM MOULD, 150x150x600 mm sides, with "X" reinforced bands on the base and upper double reinforced walls and corners. Weight: 4400 g approx.

C228 "Matest production"

CYLINDER MOULD, dia. 150 x 300 mm with upper and lower reinforced bands. Weight: 2150 g approx.

C229 "Matest production"

CYLINDER MOULD, dia. 160 x 320 mm with upper and lower reinforced bands. Weight: 2200 g approx.

C230-05

GUN, to connect to a water or air pressure, to eject the specimen from the mould.



C229

C228



C230-05



C234-02

C234-03

ACCESSORIES:

C223-01 COVER, plastic, for C223, C224 moulds. Useful for transportations. Pack of 10 pcs.

C234-02 COVER, plastic, for C230N and C230 moulds. Useful for transportations. Pack of 10 pcs.

C234-03 STOPPER, plastic, to plug the hole of the moulds C223, C224, C228, C230N, C229. Pack of 10 pcs.

C230-04 STOPPER, plastic, to plug the hole of the mould C230. Pack of 10 pcs.

C232-01 STOPPER, plastic, to plug the hole of the mould C232N. Pack of 10 pcs.

C235-01 STOPPER, plastic, to plug the hole of the moulds C235, C237, C238. Pack of 10 pcs.

C230-01 FILLING HOPPER, stainless steel made, for an easier filling of fresh concrete into the moulds: C223, C224, C230, C230N. Supplied complete of clamping elastics.

C230-03 GRASPING PLIERS for C230 and C230N moulds, to get easier the carriage.

C231N1

Polystyrene cube mould 150 mm, one gang

This cube mould, polystyrene made, is utilized for only one test, because it must be broken when the specimen is demoulded. It gives different advantages:

- it is provided of a top cover keeping inside heat and humidity constant and acting as a curing room
- it protects the specimen as a packing during transport of the same
- it is extremely light
- any trouble concerning the cleaning, demoulding and maintenance of the mould are eliminated.

Pack of 45 pieces.



C231N1



C223-05

C223-05

IDENTIFICATION LABEL. Pack of 250 labels



STEEL CUBE, CYLINDER AND BEAM MOULDS

Nominal moulds dimensions meet to requirements of

STANDARDS: EN 12390-1 / BS 1881:108 / ASTM C192, C39 / AASHTO T23, T126 / NF P18-400 / UNI 6130 / UNE 7240

Steel cube and beam moulds

These models of steel cube and beams moulds are extremely sturdy and the inside surfaces are accurately machined.

Nominal dimensions meet to EN 12390-1 requirements

MODELS:

- C247** Cube mould, 100 mm. side, 1 gang. Weight: 6 kg
- C247-01** Cube mould, 150 mm. side, 1 gang. Weight: 13 kg
- C247-02** Cube mould, 200 mm. side, 1 gang. Weight: 25 kg
- C247-03** Cube mould, 300 mm. side, 1 gang. Weight: 90 kg
- C248** Cube mould, 100 mm. side, 2 gangs. Weight: 11 kg
- C248-01** Cube mould, 150 mm. side, 2 gangs. Weight: 30 kg
- C248-02** Cube mould, 200 mm. side, 2 gangs. Weight: 45 kg
- C248-03** Cube mould, 100 mm. side, 3 gangs. Weight: 17 kg
- C248-04** Cube mould, 140 mm. side, 3 gangs. Weight: 30 kg
- C248-05** Cube mould, 150 mm. side, 3 gangs. Weight: 38 kg
- C249** Cube mould, 100 mm. side, 4 gangs. Weight: 20 kg
- C249-01** Cube mould, 150 mm. side, 4 gangs. Weight: 45 kg

C230-01

FUNNEL (FILLING HOPPER) for an easier filling of fresh concrete into the cube moulds C247-01, C253-01, C253-03. Stainless steel sheet made.



Steel cylinder moulds

STANDARDS: EN 12390-1 / ASTM C39, C192

AASHTO T23, T126 / NF P18-400 / UNE 7240

Internal surface, base, top and bottom ring are accurately machined.

Models	Dimensions Ø x height	Weight kg
C258	100x200 mm	8
C258-01	112,8x220 mm	8
C258-02	150x300 mm	15
C258-03	6" x 12"	15
C258-04	159,6x320 mm	17
C258-05	250x500 mm	80
C258-06	150x150 mm	10
C258-04 CO	159,6x320 mm fast clamping	18

section C



268



C247 ÷ C249-01

- C254** Beam mould 100x100x400 mm. Weight: 20 kg
- C254-01** Beam mould 100x100x500 mm. Weight: 23 kg
- C254-02** Beam mould 150x150x600 mm. Weight: 44 kg
- C254-03** Beam mould 150x150x750 mm. Weight: 47 kg
- C254-04** Beam mould 200x200x800 mm. Weight: 86 kg
- C254-05** Beam mould 140x140x560 mm. Weight: 38 kg



C258 ÷ C258-06



C254 ÷ C254-05



C258-04CO

Split cylinder moulds

Steel made, galvanized finishing against corrosion. Foreseen of lateral hinges for total opening and fast clamping system with inbuilt revolving screw. Complete with base. They are easy to use with practical and fast demoulding; recommended for field use.

Model	Dimensions Ø x h. (mm)	Weight kg
C259	150x300 mm	8,5
C259-01	160x320 mm	11



C259

C259-01

Cast iron cube moulds, one gang

STANDARDS: EN 12390-1 / BS 1881:108 / UNI 6127
DIN 51229

These cube moulds meet the requirements of EN 12390-1 Specifications.

They are checked in the shape, dimensions and tolerance with instruments certified by an Official SIT Institute (or equivalent), and have a Serial Number marked on each side.

The produced cube specimens meet the Standards, by avoiding to the enduser any expensive dimensional verification. Complete with base plate, clamp type.

Two models are available:

- four part wall equal design
- two part wall "V" shaped, offering more practical and fast use.

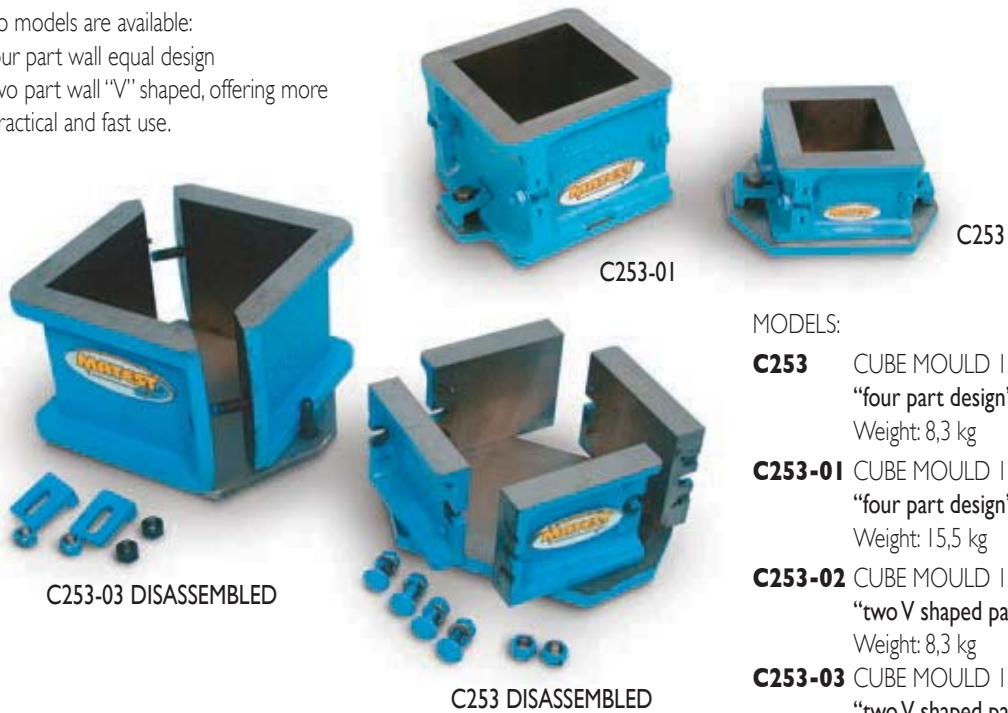

C253-03 DISASSEMBLED

C253-01

C253

C253 DISASSEMBLED

MODELS:

- C253** CUBE MOULD 100 mm cast iron, "four part design"
Weight: 8,3 kg
- C253-01** CUBE MOULD 150 mm cast iron, "four part design"
Weight: 15,5 kg
- C253-02** CUBE MOULD 100 mm cast iron, "two V shaped part design"
Weight: 8,3 kg
- C253-03** CUBE MOULD 150 mm cast iron, "two V shaped part design"
Weight: 15,5 kg

ACCESSORIES FOR MOULDS:

- C180-02** TAMPING ROD, 16 mm dia. x 610 mm. long.
- C261** TAMPING BAR, 25 mm. square area x 380 mm long.
- C262** STRAIGHT EDGE, 460 mm long.
- VI78-01** WIRE BRUSH, used to clean moulds.
- C265** DEMOULDING OIL. Can of 25 litres
- VI84-01** ROUND ALUMINIUM SCOOP 1000 ml capacity
- VI87** TROWEL STAINLESS STEEL 120x260 mm
- VI95** RUBBER MALLET, head dia. 55 mm
- VI82** MIXING TRAY, galvanized 600x600x80 mm



C180-02 ÷ VI95



Verification of flatness, perpendicularity, straightness and dimensions of moulds and specimens. STANDARDS: EN 12390-1 / ISO 1101

The appendix of EN 12390-1 Standard calls for a set of instruments to be used for dimensional and tolerance verification of the mould and the specimens got from the same.

VI75-03

VERNIER CALIPER, digital, 153 x 0,01 mm, for dimensional measurements.

VI75-03CER

VERNIER CALIPER, digital, 153 x 0,01 mm, for dimensional measurements, complete with Calibration Certificate issued by an Accredited Laboratory (SIT).

in alternative:

VI75-02

VERNIER CALIPER, digital, 200 x 0,01 mm, for dimensional measurements.

VI75-02CER

VERNIER CALIPER, digital, 200 x 0,01 mm, for dimensional measurements, complete with Calibration Certificate issued by an Accredited Laboratory (SIT).

C250-12

FEELER GAUGE, comprising a set of strips from 0,05 to 0,50 mm, with blade 100 mm long.

C250-14

RULE (straightedge), 300 mm long.

C250-16

GO-NOT GO GAUGE, for 100 mm cube moulds.

C250-16CER

GO-NOT GO GAUGE, for 100 mm cube moulds, complete with Calibration Certificate issued by an Accredited Laboratory (SIT).

C250-17

GO-NOT GO GAUGE, for 150 mm cube moulds.

C250-17CER

GO-NOT GO GAUGE, for 150 mm cube moulds, complete with Calibration Certificate issued by an Accredited Laboratory (SIT).

C250-10

RULE RIGHT ANGLE (square), steel made, 150x100 mm, rectangular section.



Dimensional verification



Flatness verification



Go-not go verification

Testing of hardened concrete
Hydraulic shrinkage determination

To measure the axial and/or superficial dimensional shrinkage of concrete specimens during hardening process in a curing room.

STANDARDS: UNI 11307:2008 / UNI 6555
(comparable to ASTM C426)

The specimen is prepared by a mould having dimensions 100x100x500 mm, with aggregates up to 30 mm max. diameter; and after housed in the measuring apparatus that determines the axial shrinkage.

The two UNI Standards require two different systems to prepare the specimen:

- The UNI 11307 requires reference pins to be stuck on the specimen.
- The UNI 6555 requires inserts fixed into the mould and let into the specimen.

EQUIPMENT TO UNI 11307:2008 Specification:

C254-01

Beam mould, steel made, to prepare a concrete specimen 100x100x500 mm. Weight: 23 kg

C366-12

Reference pin, to be stuck in the intersection of the longitudinal axis of the specimen with its bases. Pack of 10

EQUIPMENT TO UNI 6555 (comparable to ASTM C426):

C365

Shrinkage mould, steel made, complete with inserts, to prepare a concrete beam specimen 100x100x500 mm
Weight: 23 kg

C366-11

INSERTS, stainless steel, spares to C365 mould. Pack of 10

“needed” ACCESSORIES, conforming to: UNI 11307:2008 and UNI 6555



C364

Measuring apparatus, for 100x100x500 specimens, complete with reference bar, but “without” dial gauge to be ordered separately. Weight: 23 kg

S375 DIAL GAUGE, 5 mm stroke by 0,001 mm sens.

AS AN ALTERNATIVE:

S376 DIAL GAUGE, 10 mm stroke by 0,01 mm sens.

AS AN ALTERNATIVE:

S382-02 DIGITAL GAUGE indicator travel: 15,3 mm, division: 0,001 mm
Including battery but “without” RS232 port.

AS AN ALTERNATIVE:

S382-01 DIGITAL GAUGE indicator, with readings in mm (sens. 0,001 mm) and in inch (sens. 0,0001”), battery feeded. Complete with battery and RS232 connector to PC.

S382-13 SOFTWARE for S382-01 gauge, complete with USB adaptor and connection cable to PC.



Determination of restrained expansion of a concrete or mortar specimen containing the expansive agent, and the effect of the aggregates on the drying shrinkage of concrete.

The mould, steel made, is supplied complete with 3 screwed rods and 6 restrained end plates.

MODELS:

E114

THREE GANG PRISM MOULD, to produce 80x80x240 mm specimens. STANDARD: UNI 8148 . Weight: 15 kg

E114-02 Restrained end plate 80x80 mm; spare to E114 mould.

E115

THREE GANG PRISM MOULD, to produce 50x50x250 mm specimens. STANDARD: UNI 8147. Weight: 10 kg

E115-02 Restrained end plate 50x50 mm; spare to E115 mould.

E115-01 Steel screwed rod 280 mm long; spare to E114 and E115 moulds.



ACCESSORIES:

E077 KIT LENGTH COMPARATOR, with analogic dial to measure linear variations. Technical details: see pag. 321

AS AN ALTERNATIVE:

E078 KIT - E077-01 KIT

LENGTH COMPARATOR, with digital dial to measure linear variations. Technical details: see pag. 321

E078-05 REFERENCE ROD, 280 mm long



VIBRATING TABLES

STANDARDS: EN 12390-2 / BS 1881:108 / UNI 6127

Used for the compaction of concrete specimens in laboratory, they are manufactured from rugged steel sheet.

Equipped with motor-vibrator having 3000 vibrations-minute, it is possible to vary the vibration intensity by acting on the excentric masses. The height of the table is 410 mm.

All the vibrating tables accept the clamping device, pedal switch or control panel (see accessories). Power supply: 230 V 1ph 50 Hz

section C

Models	Table dimensions mm	Power W	Weight kg	*Clamping device
C278	600x400	180	60	C281-01
C278-01	800x400	180	85	C281-02
C278-02	800x800	180	115	C281-03
C279	1100x550	180	145	C281-04

*The clamping device is used to fix the moulds to the table during the vibrating action.



C278 with moulds C253-01



C279



C281N



C278-02

PORTABLE VIBRATING TABLES

Similar to the above Vibrating Tables, suitable for site and laboratory use, they accept ONE GANG cube moulds (max. 200 mm side) or cylinders max. 160x320mm, both plastic and metal made.

Supplied complete with elastic bands to fix the mould to the table.

Table dimensions: 400x300mm, height 200mm

Weight: 16 kg

MODELS:

C281N

Vibrating table, portable, 12V dc

Suitable for site use, where no electric supply is available.

Lightweight and small sized, it can be handled by one person and easily stored in the car trunk.

Supplied complete with On/Off switch and connector for the vehicle cigar lighter

C282

Vibrating table

Similar to mod. C281N, but for laboratory use

Power supply:

230V 1ph 50Hz 110W



C282



C282



ACCESSORIES FOR VIBRATING TABLES:

C279-04

PEDAL SWITCH, water tight. It can be fixed to the table "only as an alternative" to the Control Panel mod. C279-02

C279-02

CONTROL PANEL, separate, complete with On/Off switch and timer; getting also the tables to CE Safety Directive. It cannot be used with the table mod. C281N

C281-05

CLAMPING DEVICE, to fix the mould to the table, suitable "only" for tables mod. C281N and C282. Alternative solution to the elastic bands. Recommended for the laboratory table C282

C279-01

MOTOR-VIBRATOR, additional, (only for table mod. C279) to obtain an unidirectional vibration and a vibrating power of 300 kg of mass.

POKER VIBRATORS

STANDARDS: EN 12390-2 / ASTM C31, C192
AASHTO T23, T126 / BS 1881:108 / UNI 6137

Suitable for the internal compaction of concrete specimens both in laboratory and in site.

The diameter of the needle must not exceed the 25% of the smallest dimension of the specimen.

Different models available: electric, petrol, battery operated

C270N

POKER VIBRATOR, HEAVY DUTY, portable, electric.
Tip dimensions: 25 mm dia. by 290 mm long.
Flexible shaft 2 metres long.
Frequency: 18000 vibr/minute.
Amplitude: 0,65 mm
Centrifugal force: 0,8 kN (80 kg)
Power supply: 230V 1ph 50/60Hz 2300W
Dimensions: 200 x 300 x 350 mm approx.
Weight : 10 kg approx.

SPARES:

C270-10N

TIP, 25 mm dia. by 290 mm long, complete with flexible shaft 2 metres long, for the vibrator mod. C270N.

C271-10

TIP, 22 mm dia. by 250 mm long, complete with flexible shaft 2 metres long, for the vibrators mod. C271 and C274.

C271-10N

TIP, 25 mm dia. by 250 mm long, complete with flexible shaft 2 metres long, for the vibrator C271N

C271N

POKER VIBRATOR, portable, petrol operated.
Honda motor; 4-stroke, 1,6HP, 35,8cc
Tip dimensions: 25 mm dia. by 250 mm long.
Flexible shaft: 2 metres long.
Frequency: 10000 vibrations/min.
Supplied complete with knapsack.
Weight: 7 kg approx.



C271N

C274

POKER VIBRATOR, portable, to be connected to a 12V DC battery car.
Complete with connector for car lighter.
Tip dimensions: 22 mm dia. by 250 mm long
Flexible shaft 2 metres long
Frequency: 12000 vibrations/min.
Weight: 10 kg approx.



C274



C270N



C270-10N



CURING TANKS FOR CONCRETE SPECIMENS

STANDARDS: EN 12390-2 / ASTM C31, C192, C511
AASHTO T23 / NF P18-404 / UNI 6127, 6128, 6129
BS 1881:111 / UNE 7240

C302 KIT

Curing tank 650 litres capacity, heavy plastic

Made from extremely robust and stable polyethylene, complete with base rack.

Supplied "without" thermostat heating system, to be ordered separately (see accessories).

Inside dimensions: 1040x1040x605 mm

Weight: 60 kg



C302 KIT

C302-10 KIT

Curing tank, 550 litres capacity, heavy plastic

Same to mod C302 but having:

"Water discharge cock incorporated into the tank"

Inside dimensions: 1100 x 710 xh 690 mm

Overall dimensions: 1200 x 800 xh 850 mm

Weight: 55 kg



C302-10 KIT

DISCHARGE COCK

C304

Curing tank 1000 litres capacity

Made from steel sheet, zinc coated to prevent it from corrosion.

Complete with base rack and stopper for an easy water discharge.

Supplied "without" thermostat heating system, to be ordered separately (see accessories).

The tank can accommodate up to 64 cubes 150mm side, or up to 48 cubes 200mm side.

Inside dimensions: 1500x750x750 mm

Weight: 120 kg

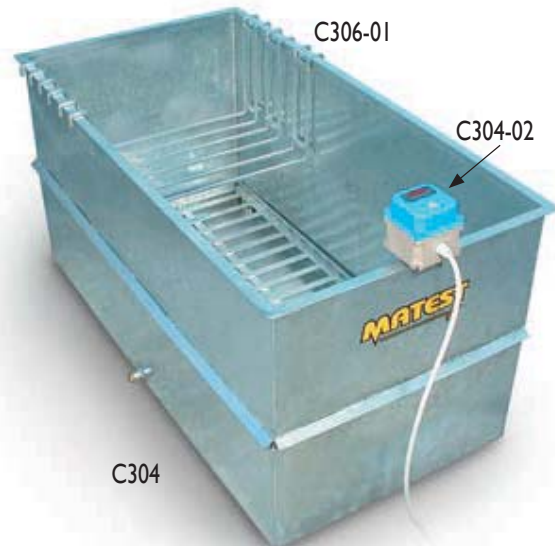

C304

"NEEDED" ACCESSORY:

Available in two versions:

C302-01

THERMOSTAT ANALOGIC HEATING SYSTEM,

for the tank mod. C302 KIT

230V 1ph 50/60Hz 2000W

C304-01

THERMOSTAT ANALOGIC

HEATING SYSTEM,

for the tanks mod. C302-10 KIT

and C304

230V 1ph 50/60Hz 2000W

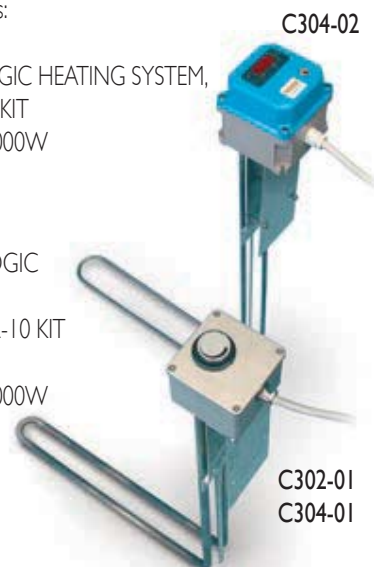

C304-02

C302-01
C304-01

AS AN ALTERNATIVE:

C304-02

THERMOSTAT DIGITAL HEATING SYSTEM

for the tanks mod. C302 KIT,

C302-10 KIT and C304,

"ensuring better

temperature accuracy"

230V 1ph 50/60Hz 2000W

C304-02 DETAIL



ACCESSORIES FOR TANKS MOD. C302 KIT, C302-10 KIT, C304:

- C305-01** Plastic cover for the C302 KIT tank
- C302-11** Plastic cover for the C302-10 KIT tank
- C306-04** Steel zinc coated cover for the C304 tank
- C306-01** Upper rack for the C304 tank to store cubes max. 150 mm max. 8 racks per tank
- C306-02** Submersible water circulating pump, also used for an easy water discharge from the tank 230V 1ph 50/60Hz



C306-03
Separate control panel, complete with switch and electric protections, to get the tanks to CE Safety Directive

C306-05
Analogic thermostat, complete with heating element. Used to thermostate any type of tank from 300 to 1000 litres capacity. Power supply: 230V 1ph 50/60Hz 2000W



E141

E141
WATER REFRIGERATOR
It cools the water from room temperature up to +10°C. It is connected to the tank where a lower temperature than the room one is required. See Section "E" Cement, pag. 335

C307
Accelerated concrete curing tank

STANDARDS: ASTM C684 / BS 1881:112
This tank has been designed for accelerated concrete strength curing. It comprises a fully insulated double wall tank with cover, inside all from stainless steel, outside from steel painted sheet with an intermediate layer of insulating mineral wool. This tank can hold up to 16 cubic 150 mm. side specimens; or 16 cylindrical dia. 150 mm. specimens; or 8 cubic 200 mm. side specimens. The test consists essentially in curing the concrete specimens with water heated by 3 electric elements of 1500W each. Temperature range: from ambient to 100 °C. The separate control panel is provided with a thermoregulator; timer; pilot lights; main switch. Inside dimensions: 910x660x680 mm Overall dimensions: 970x720x900 mm Power supply: 230V 1ph 50/60 Hz 4500W. Weight: 130 kg

Equipment to prepare a temperature and humidity controlled room.

The following equipment are suggested as alternative to the curing tanks and climatic chambers indicated in this catalogue or by necessity of a wide area for curing a big quantity of specimens. They are suitable to prepare an already existing room/box or one to be realized by the customer. The temperature of the room can be only increased compared to the external temperature but not decreased.

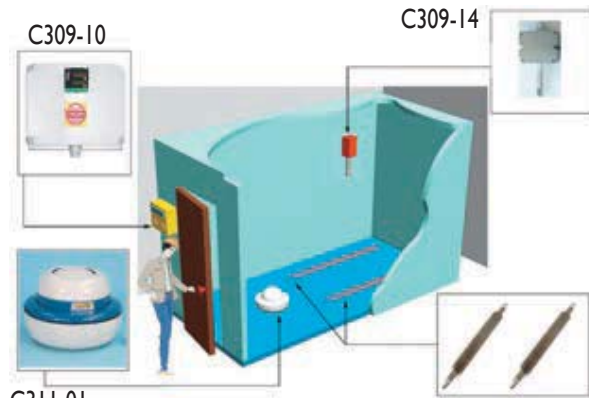

Example how to prepare a curing room

Needed devices:
C309-10
CONTROL PANEL of temperature and humidity. It is usually placed on the outer side of the room, and allows to set, display and control the desired parameters of temperature and humidity. Power supply: 230V 1F 50/60Hz Dimensions: 240x130x310 mm approx. Weight: 5 kg

C309-12
HEATING RESISTANCE in tubular frame, finned type. Normally one heating resistance is enough for its purpose, provided that the range between the external and internal temperature set in the room (anyway well insulated) is kept within 15°C. Dimensions: dia. 40x1100 mm. Weight: 2000 g approx.

C309-14
SENSOR PROBE to measure temperature and humidity. Temperature measuring range from -10 to +90°C and humidity up to 100%. It is fixed inside the room and connected to the control panel.

C311-01
VAPORISER
Used to humidify curing rooms up to 150 cubic/metre. Technical data: see pag. 277



C307

section C



C313

Climatic controlled cabinet 700 litres cap.

- Temperature: -25 to +70°C, stability 0,1°C
- Humidity: 10 to 90%, accuracy ± 1%
- Dew point: +2°C

STANDARDS: EN 196-1, EN 1367-1, EN 12390-2, EN 12390-9

Designed for all the research and control laboratories to perform: cold and/or hot temperature measurement at controlled humidity conditions, any kind of freezing/thawing tests, accelerated curing tests.

Used to cure concrete (EN 12390-2) and cement specimens (EN 196-1), to analyze the behaviour to freezing and thawing of aggregates (EN 1367-1) and concrete (EN 12390-9).

Internal capacity: 700 litres.

Internal and external frame made of stainless steel AISI 304.

Polyurethane insulation, 75 mm thick.

Internal ventilation.

Reversible doors with autoclosing hinges and opening lock beyond 90°, rechargeable magnetic gaskets, rounded corners, inside doors in lexan.

Shelves can be taken off and adjustable in height; adjustable feet.

Temperature sensor can be placed at every point of the climatic cabinet; it can also be placed within the specimen.

The cabinet is supplied with a “**decalcification filter**”; it works with demineralized or softened waters, or aqueduct waters with CaCO₃ hardness from 0 to 400 ppm, assuring an excellent functioning along the time.

Complete with microprocessor one cycle programmer and 20 temperature segments.

Real-time visualization of the internal temperature and of the set temperature on the digital display.

Audiovisual alarm of minimum and maximum temperature (audio signal can be switched off).

Password to access the cabinet commands.

Security device Class 3.1 (DIN 12880) with automatic activation of two further security thermoregulators.

Supplied complete with 3 adjustable shelves.

Inside dimensions:

600x670x1350 mm

Overall dimensions:

720x800x2070 mm

Power supply:

230V 1ph 50/60 Hz 1800W

Weight approx.: 180 kg



Detail of the control panel

- Temperature control (%)
- Humidity inside the chamber (%)
- Humidity control (%)
- Internal temperature of the chamber
- Set Point temperature
- Humidity Set Point



C313

C313-01

Climatic cabinet 1500 litres cap.

Same as C313 model, but with an internal capacity of 1500 litres.

Supplied complete with 6 adjustable shelves.

Inside dimensions: 1320x670x1350 mm

Overall dimensions: 1440x800x2070 mm

Weight: about 360 kg

ACCESSORIES:

C313-11 PROGRAMMER, 10 cycles (programs) and 50 different linear temperature segments (as alternative to the programmer supplied with the cabinet).

C313-12 PROGRAMMER, 25 cycles and 100 different linear temperature segments.

C313-13 PROGRAMMER, 50 cycles and 200 different linear temperature segments.

C313-15 DATA LOGGER for temperature and humidity recording and monitoring, complete with software and connecting cable for data transfer to PC.

UNBONDED CAPPING PADS AND RETAINERS

STANDARD: ASTM C1231

Used for compression tests on concrete cylinder specimens, as an alternative method to the sulphur capping and grinding machine.

Two steel capping retainers are applied on the two flat surfaces of the cylinder:

Two neoprene pads are put between them, for a better load distribution.

The neoprene pads are available in two models:

- 60 shore hardness pads for expected strength from 10 to 48 MPa
- 70 shore hardness pads for expected strength over 48 MPa

The system is not applicable for expected strength lower than 10 Mpa

The couple of retainers + neoprene pads have a total thickness of 46 mm. Therefore the testing chamber of the press must have more vertical clearance than the height of the specimen + 46 mm.

MODELS:

C107-09 CAPPING RETAINERS (couple) for dia. 100x200mm cylinders.

C107-10 CAPPING RETAINERS (couple) for dia. 150x300mm and 6"x12" cylinders.

C107-12 CAPPING RETAINERS (couple) for dia. 160x320 mm cylinders

C107-18 NEOPRENE PADS (couple) 60 shore A for dia. 100x200mm cylinders

C107-19 NEOPRENE PADS (couple) 70 shore A for dia. 100x200mm cylinders

C107-20 NEOPRENE PADS (couple) 60 shore for dia. 150x300mm and 6"x12" cylinders

C107-21 NEOPRENE PADS (couple) 70 shore for dia. 150x300mm and 6"x12" cylinders

C107-25 NEOPRENE PADS (couple) 60 shore for dia. 160x320mm cylinders

C107-26 NEOPRENE PADS (couple) 70 shore for dia. 160x320mm cylinders

C107-29 NEOPRENE SHEET (couple) 60 shore A dimensions: 600x400x12mm for test on blocks.

C311-01

Curing room vaporiser up to 150 m³

Used to humidify curing rooms for concrete and mortar specimens.

Max. room capacity: 150 cubic/metre.

Supplied complete of "level regulator" with antioverflow, that allows the direct connection to the water net, for a continuous use of the vaporiser.

Power supply: 230V 1ph 50 Hz

Dimensions: dia. 360x230 mm. Weight: 3,5 kg



C311-01

C312-10

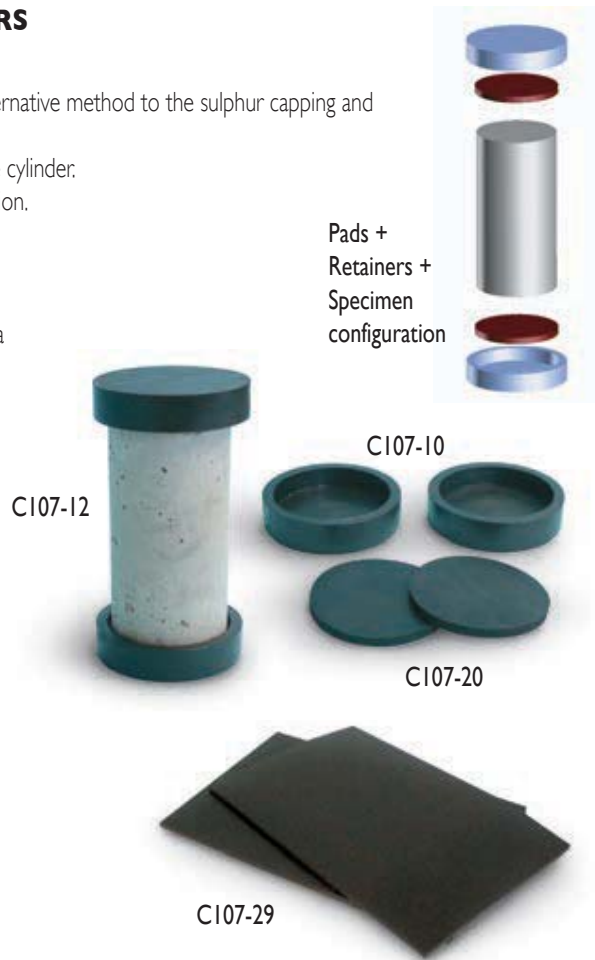

Pads + Retainers + Specimen configuration

C107-10

C107-12

C107-20

C107-29

C312-02

Curing room vaporiser up to 500 m³

Same to mod. C311-01, but more powerful for rooms up to 500 cubic/metre capacity.

Supplied complete of "level regulator" with antioverflow, that allows the direct connection to the water net, for a continuous use of the vaporiser.

Power supply:

230V 1ph 50 Hz

Dimensions:

dia. 420x350 mm

Weight: 8 kg



C312-02

ACCESSORY FOR MOD. C311-01, C312-02:

C312-10

HUMIDISTAT to automatically control the room humidity, range 30 ÷ 100 %

SPARE:

C312-11

LEVEL REGULATOR, complete of antioverflow.

section C



CYLINDER CAPPING EQUIPMENT

Sulphur method

STANDARDS: EN 12390-3 / ASTM C617, C31, C192 / AASHTO T23, T126 / NF P18-416 / UNI 6132 / UNE 7240, 83303

The above mentioned Specifications require that the two faces of the concrete core or cylinder specimen must be made perfectly flat and parallel, by using sulphur capping equipment.

section C



278

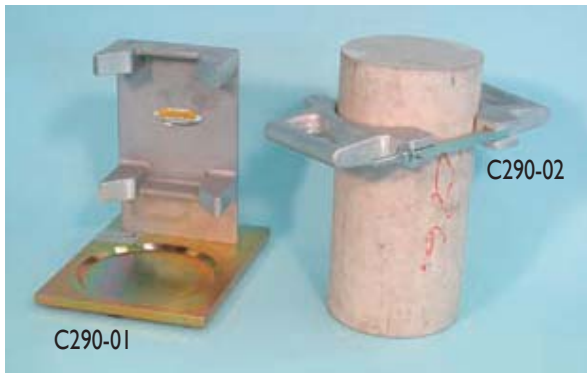

Cylinder cappers

To obtain plane end surfaces perpendicular to the axis of the cylinder:

Model	Cylinder dia. x h	Weight kg
C290-01	150x300mm, 6"x12"	6,3
C291-01	160x320 mm	6,2
C292-01	100x200 mm	4,4

C290-02

CYLINDER CARRIER, for dia. 150x300mm, 160x320mm and 6"x 12". For an easier handling of the specimens.

Weight: 1,4 kg

MELTING POT for capping compound.

Used to melt the sulphur capping compound. Complete with thermostat. Suitable also for general laboratory purposes.

AVAILABLE MODELS:

C290-03 KIT MELTING POT, capacity : 4 litres. Inexpensive model. 230V 1ph 50/60Hz 1500W

A106

MELTING POT, capacity: 5 litres

Temperature range: +50 to +350°C., accuracy: +/- 1,5°C.

Complete with pilot lamp, fully isolated to CE Safety Directive.

Internal dimensions: dia. 200 mm x 160 mm

230V 1ph 50/60Hz 800W. Weight: 3 kg



C290-06

CAPPING COMPOUND, ultra strong flake type.

This compound is a mixture of sulphur and mineral filler; the compressive strength of 8000 - 9000 Psi is granted (at two hours) on a 2" cube specimen, as requested by ASTM C617 Standard.

On a 150 mm dia. cylinder the compressive strength is 16000 Psi. Melting point is 115 to 143°C. (ideal: 130°C.)

Bag of 22,5 kg (50 lbs)

C290-07

CAPPING COMPOUND, of sulphur and mineral powder mixture, with minimum strength of 55 Mpa.

Bag of 20 kg

V186-01 LADLE, stainless steel made.

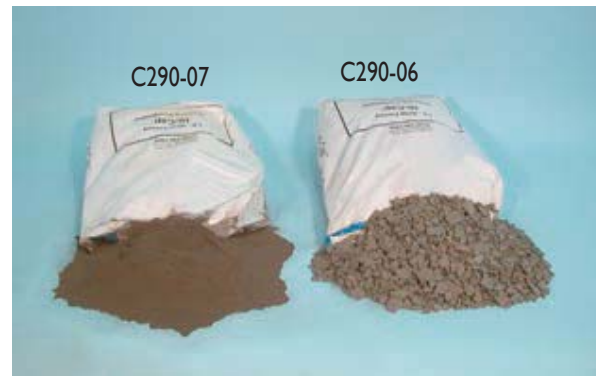

OTHER MODELS:

C294-01 Vertical cylinder capper for dia. 250x500 mm

C294-02 Cylinder carrier for dia. 250x500 mm

C294-05 Vertical cylinder capper for dia. 60x120 mm

C294-05



C296

Steel capping plate, used for capping concrete blocks up to 500x300 mm

The plate surface is accurately machined.

Dimensions: 500x300x20 mm. Weight: 30 kg

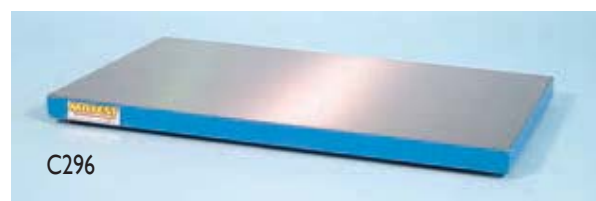

C298

SPECIMEN GRINDING MACHINE

STANDARDS: EN 12390-2 / ASTM D4543 / UNI 6132
Designed to grind and polish concrete cube and cylinder specimens, blocks, natural stones, rocks, ceramic materials etc.

The specimens are easily fixed to the table by proper locking stirrups (see accessories) allowing to grind at a time:

- n° 3 cube specimens 100mm side, or
- n° 3 cube specimens 150mm side, or
- n° 2 cube specimens 200mm side, or
- n° 2 cylinder specimens dia. 100x200, 110x220, 150x300, 160x320mm, or
- n° 1 block with max. dimensions 390x250mm

The revolving abrasive head is radially and alternatively moved in both directions through an electric motor actuated by a pushbutton.

The column is completely protected against the abrasive dust.

The vertical lowering of the grinding head is achieved with infinitesimal adjustments by operating on the top handwheel having 0,05mm graduations.

The machine, made from rugged plate, is supplied complete with control panel, coolant/decantation tank (by water and emulsifying oil), motor pump, set of abrasive sectors, safety chip guard that when removed, stops automatically the machine.

The standard supply "does not include":

- the locking stirrups,
 - the diamond sectors (8 pieces)
- that must be ordered separately (see accessories)

Technical specifications:

- Table dimensions: 775x280mm (usefull: 750x250mm)
- Grinding wheel dia.: 330mm
- Vertical span width: min. 125mm, max. 330mm
- Grinding head stroke: 205mm
- Grinding wheel speed: 1400 rpm.
- Power supply: 400V 3ph 50Hz 4500W
- Dimensions: 1220x1080x (h) 1730mm
- Weight: 410 kg approx.



C298 / C299
with C300-06N

section C



279

C299

AUTOMATIC GRINDING MACHINE

Same to mod. C298, but the radial movement of the head is equipped with end of stroke system, granting the fully automatic displacement in both directions without activating the electric pushbutton.

"NEEDED" ACCESSORIES:

C300-06N

LOCKING STIRRUPS for cube specimens side 100, 150, 200mm complete with distance piece 60mm high.

AS AN ALTERNATIVE:

C299-10

FAST LOCKING DEVICE, for:
cubes 150 and 200mm;
cylinders dia. 100 to 160mm
Each device accepts only one specimen.
It is possible to grind at a time:
1 cube 200mm; 2 cubes 150mm;
2 cylinders.



C299-10

C300-02

DIAMOND GRINDING SECTOR (8 pieces required) "particularly recommended" because of their long duration and good grinding action.



C300-02

ACCESSORIES:

C300-03

LOCKING STIRRUPS for cylinder specimens dia. 100, 110, 150, 160mm. They can be used only in conjunction with the C300-06N stirrups.

C300-07N

LOCKING STIRRUPS to grind blocks of different sizes, but with max. dimensions of 390x250mm

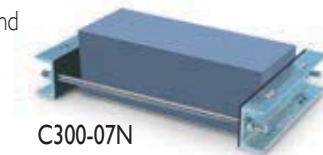

C300-07N

C300-08

Core face preparation device

It prepares parallel and flat core faces or rock samples. The device accepts up to 4 core samples from 20 to 55mm dia. and can be mounted on most grinding machines.
Weight: 7 kg approx



C300-08

C300-01

ABRASIVE DRINDING SECTORS, spare, set of 8 pieces.

MATEST

CORE DRILLING MACHINES “LIGHTWEIGHT, PORTABLE”

General description:

These drilling machines are extremely practical, lightweight, easy to use.

The base is from aluminium alloy, the steel column can be tilted up to 45°, the motor support is fixed on a saddle sliding on teflon runner granting high performances. The motor incorporates a water swivel to cool the diamond bit.

The machine is supplied complete “except”: diamond bit, spanner, core extractor (see accessories next page) to be ordered separately.

C318N

Core drilling machine, electric motor

Electric motor at three speeds: 530, 1280, 1780 rpm, with speed reducer, provided of multifunction electronic friction device and switch to CE Safety Directive.

The machine accepts bits dia. 50 to 150 mm

Power supply: 230V 1 ph 50/60Hz 2200W

Dimensions: 600x320x1020 mm

Weight: 24 kg



C324N

Electric core drilling machine with vacuum facility

The frame and the electric motor are the same of mod. C318N.

The machine is supplied complete with lubricated vacuum pump and pressure accumulation reservoir, which is very useful because it maintains for some times a valid vacuum level also with electric blackout, by avoiding the fall or disconnection of the unit from the wall.

The pump is connected to the utility by means of a ball tap to which a vacuum gage is fitted, that constantly indicates the pressure inside the tank.

Coring angle: 0 to 360° under the condition that the surface is sufficiently flat, and not too porous, to allow the vacuum attachment.

Power supply: 230V 1 ph 50/60Hz 2200W

Dimensions: 600x320x1020 mm + pump

Weight: 24 kg + pump 15 kg

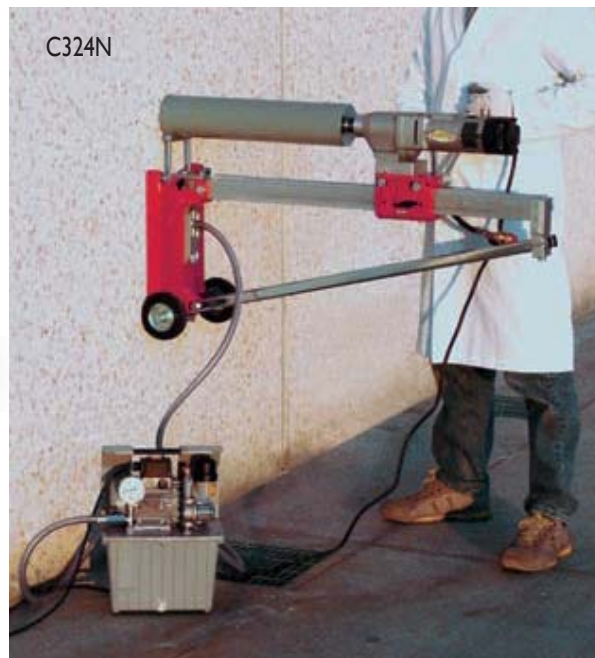

ACCESSORY:

C318-10



C318-10

WATER COLLECTING RING, confining waste water on the surface, for machine mod. C318N and C324N. It has to be connected to a suitable electric pump.



C332

C332

PORTABLE ELECTRIC GENERATOR

To use with electrically driven machines where electrical power is not available. The generator is rated at 4000 Watt and it supplies: 230V 1 ph 50 Hz.

Complete with tank, accessories.

Weight: 60 kg



CORE DRILLING MACHINES “HIGH PERFORMANCE”

General description:

These drilling machines are extremely robust, heavy duty, compact and reliable.

The sliding group is rectified so as to assure a very soft and accurate drilling movement.

The drilling excursion is 550 mm and the machine can drill cores up to 200 mm dia.

Built in water swivel to cool the diamond bit.

The robust steel base is equipped with wheels for easy site displacements, together with four levelling and stabilizing feet.

All working and moving parts are cadmium plated for rust protection.

The machine is supplied complete “except”: diamond bit, core extractor and spanner (see accessories at pag. 282) which have to be ordered separately.

MODELS:

C319

**Pavement core drilling machine 5HP
4-stroke petrol engine**

This rugged, compact and portable machine with vertical screw feed, is used for pavement core sampling where it is not easy to get electrical power.

Petrol engine 5 HP power, 4-stroke Briggs & Stratton model.

Dimensions: 850x580x1230 mm

Weight: 135 kg

- Original Briggs & Stratton motor
- It can drill cores up to 200 mm dia.
- Vertical rectified screw feed
- Built in water swivel to cool the bit
- Rugged, compact, wheels mounted



C319



C319-02

C319-02

**Pavement core drilling machine 12,5HP
4-stroke petrol engine**

Same to mod. C319, but activated by a petrol engine 12,5 HP power 4-stroke Briggs & Stratton model.

Weight: 150 kg

SPARE PARTS:

C331 PETROL ENGINE, for C319 machine 5 HP power, 4-stroke Briggs & Stratton model. Supplied complete with tank, accessories Weight: 20 kg

C331-02 PETROL ENGINE for the C319-02 drilling machine. 12,5 HP power, 4-stroke Briggs & Stratton model. Supplied complete with tank, accessories. Weight: 25 kg



C322 KIT

Universal electric core drilling machine

Comprising:

C321-10 UNIVERSAL DRILLING FRAME COMPLETE,
but without electric motor

C330 ELECTRIC MOTOR COMPLETE

Coring angle: 0 to 360°

The excursion group is rectified to assure a very soft and accurate drilling movement. The excursion is 550 mm.

Electric motor at three speeds: 670, 1140, 1580 rpm with speed reducer; provided of friction device and switch to CE Safety Directive.

The height of the vertical column is 1000 mm and it is pre-built for extension column connection (accessory mod. C322-01).

Power supply: 230V 1ph 50/60 Hz 2200 W

Dimensions: 440x750x1300 mm

Weight: 85 kg

ACCESSORY:

C322-01

EXTENSION COLUMN, 1000 mm long, to connect to mod. C322 KIT for drillings over 1 metre from the ground.

Supplied complete with clamping devices.

Cadmium plated for rust protection.

SPARE PART:

C330

ELECTRIC MOTOR, for C318N, C322 KIT and C324N

Power 2200 Watt, three speeds 670 - 1140 - 1580 rpm complete with friction device, and connection to coolant water supply.

Double extremely safe isolation and switch to CE Safety Directive. Connection to hub 1 1/4".

Power supply: 230V 1ph 50/60 Hz 2200 W. Weight: 9 kg

Diamond core drill bits "with" backend screwed connector

Designed for making holes and to get cores from hard materials, like concrete, reinforced concrete, rocks, stones, bituminous materials.

The diamond utilized for these bits is quality impregnated sinterized type.

The diamond segment is "9 mm high". The 9mm high segment is important for the bit life, because the diamond is about the 85% of the bit value.

The coupling between the bit and the motor shaft is direct through the backend screwed connector.

This diamond bit model is suitable to drill both reinforced concrete and also bituminous materials.



C322 KIT



C346 ÷ C346-04

C345

C344

C344-01

- C344** Strap wrench useful for unblocking any type of bit.
- C344-01** Strap wrench useful for unblocking only the bits with backend screwed connector.
- C345** Extension rod 300 mm. long (used for deep holes).



C339-01 ÷ C339-05

Model	Outside Dia. mm	Inside Dia. mm	Bit length mm	Expander Coupling	Core Extractor
C339-01	57	50	450	no	C346
C339-02	82	75	450	no	C346-01
C339-03	108	100	450	no	C346-02
C339-04	160	152	450	no	C346-03
C339-05	210	200	500	no	C346-04

The core extractor allows an easy removal of the core sample from the hole.



C348N

Specimen cutting machine with sliding supports

The machine accepts blades up to dia. 400 mm
 Useful cutting height: 115 mm
 Dimensions of the sliding table: 550x410 mm
 Blade rotation speed: 2800 rpm
 Supplied "without" blade
 (see accessories)
 Power supply:
 230V 1ph 50 Hz 3 Hp
 Dimensions:
 700x1100x680 mm
 Weight: 80 kg



C348 N

C350

Specimen cutting machine

Used to cut concrete specimens and any type of construction material like blocks, tiles, pipes, rock cores etc. The machine is equipped of an electro-pump for water cooling, pedal guide for vertical cutting, safety device against breakage of blade.
 The machine accepts blades up to dia. 450 mm
 Supplied "without" blade (see accessories)
 Power supply:
 400V 3ph 50 Hz 4 Hp
 Dimensions: 1220x700x1360 mm
 Weight: 125 kg



C350

C350-01

Specimen cutting machine

Identical to mod. C350, but with:
 Power supply: 230V 1ph 50 Hz 4 Hp

C349

Specimen cutting machine

Basically similar to mod. C350, but it can accept blade having max. dia. 500 mm. Power supply: 400V 3ph 50 Hz 5 Hp

C351

Specimen cutting machine, bench type

The machine accepts blades up to dia. 350 mm
 Shear capacity: 120 mm
 Blade rotation speed: 3900 rpm
 Supplied complete with abrasive blade dia. 350 mm
 Power supply: 230V 1ph 50 Hz 2000 W
 Dimensions: 560x460x390 mm. Weight: 20 kg

ACCESSORIES:

C350-12 DIAMOND BLADE dia. 450 mm., having long life for a faster and more precise cutting operation. Suitable for models C350 and C350-01.

C350-13 DIAMOND BLADE, dia. 350 mm for mod. C351

C350-14 DIAMOND BLADE, dia. 400 mm for mod. C348N

C350-15 DIAMOND BLADE, dia. 500 mm for mod. C349

C350-10 ABRASIVE BLADE dia. 350 mm for mod. C351

NOTE:

It is recommended to use the blade having the max. diameter accepted by the cutting machine.



C351

C352

DEVICE FOR CYLINDERS AND CORES

To clamp and cut cylinders and cores dia 100 to 160 mm. The device is fixed to the table of the cutting machines mod. C348N, C350, C350-01, C349. Weight 10 kg

C352 SP

DEVICE FOR CORES, as above, but dia. 55 to 160 mm.

C353

DEVICE FOR IRREGULAR SHAPES

To clamp and to cut irregular shaped specimens, like rocks, stones etc. The device is fixed to the table of the cutting machine mod. C348N, C350, C350-01, C349. Weight: 5 kg



C353



C377

Micro-coring equipment

STANDARD: UNI 10766

The extraction of a micro-core sample from a concrete structure or masonry is an extremely valid non-destructive method, as it allows analysis and accurate evaluations of the manufacture (compression resistance, ecc.) without causing any damages to the structure, considering the dimension of the hole that can be eventually clogged with mortar:

Micro-coring system is ulteriorly valid and reliable if combined with ultrasonic tester and concrete hammer.

Micro-core extraction is easy, and requires the presence of one operator only.

The equipment comprises:

- Suitable electric drill, 230V 1F 50Hz
- Flanged guide assembly
- Drilling mask
- Impregnated diamond bit for cores with $\varnothing 28 \times 100$ mm
- Impregnated diamond bit for cores with $\varnothing 28 \times 200$ mm
- 2 Self-blocking pincers to fit the flanged guide assembly to the surface

Set of accessories comprising: anchors, bits, wrenches, screws.

Carrying case.

Dimensions: 550x400x200 mm approx.

Weight: 10 kg. approx.

C377-05

TRIMMING/CUT-OFF MACHINE FOR CORES.

Suitable to cut and trim cores to be prepared for compression tests, where the flatness of both surfaces is a basic condition to obtain correct results.

The equipment is made of stainless steel and aluminum and it is supplied complete with diamond blade dia. 180 mm.

For this purpose it must be used the drill mod. C377-10 (enclosed into micro-coring equipment) and the water tank with foot pump mod. C377-01.



C377-05

Note:

The maximum values foreseen for compression tests on micro-cores are usually lower than 60 kN. Portable compression machine mod. C094 (see pag. 249), or a cement compression tester (see pag. 342) may be conveniently used.

Trimming of cores may be even obtained with the grinding machine mod. C298 + device mod. C300-08 (see pag. 279)



C377

C377-01

ACCESSORIES:

C377-01

WATER TANK WITH FOOT PUMP, that leaves the hands of the operators free for coring

AS ALTERNATIVE:

C377-02

AIR-WATER PRESSURE TANK, 10 liters capacity

C377-02



SPARE PARTS:

C377-10 ELECTRIC DRILL, suitable for the microcoring purposes.

C377-15 DIAMOND BIT, dia. 28 x 100 mm

C377-16 DIAMOND BIT, dia. 28 x 200 mm



Mechanical strain gauges

STANDARDS: ASTM C426 / BS 1881:206

Used to determine the strain (length changes) in concrete specimens and structures, rock strata, different parts of a structure, in remote areas and under adverse conditions, using a single instrument. Different models are available with analogic or digital gauge, 100, 200, 300 mm measuring length, depending on the standard length to be measured. The instrument can also be used for other structures like steel and wood.

The standard equipment comprises:

- Strain gauge (extensometer) complete with analogic or digital indicator 0,001 mm graduations (see available models)
 - Calibration bar used also to fix the datum disc on the structure.
 - 50 datum discs.
 - Adhesive compound for datum discs.
- The whole contained in carrying case.

MODELS WITH “analogic gauge” 0,001 mm graduations:

- C360 KIT** STRAIN GAUGE, 100 mm measuring length, complete.
- C360-01 KIT** STRAIN GAUGE, 200 mm measuring length, complete.
- C361 KIT** STRAIN GAUGE, 300 mm measuring length, complete.

MODELS WITH “digital gauge”, battery feeded, with reading values in mm (sens. 0,001 mm) and inch.

Complete with battery, but “without” RS232 port.

- C359 KIT** STRAIN GAUGE, 300 mm measuring length, complete
- C359-01 KIT** STRAIN GAUGE, 100 mm measuring length, complete
- C359-02 KIT** STRAIN GAUGE, 200 mm measuring length, complete



C359-01 KIT

MODELS WITH “digital gauge”, battery feeded, with reading values in mm (sens. 0,001 mm) and in inch (sens. 0,0001”).

Complete with battery and RS232 connector to PC.

- C363 KIT** STRAIN GAUGE, 300 mm measuring length, complete.
- C363-01 KIT** STRAIN GAUGE, 100 mm measuring length, complete.
- C363-02 KIT** STRAIN GAUGE, 200 mm measuring length, complete.

ACCESSORY for C363 serie models:

S382-13

Software, complete with USB adaptor and connection cable to PC

SPARE PARTS:

- C362-01** DATUM DISC (pack of 50)
- C362-02** ADHESIVE compound.



C361 KIT



C363 KIT

C399

Crack detection microscope

Used to measure crack width in concrete structures, by operating via an adjustable light source.

High definition unit, provided by power batteries, carrying case.

The eyepiece scale can be turned through 360° to align with the direction of the crack under detection.

Measuring range:

4 mm. and div. 0,02 mm.

Magnification: x35

Weight: 600 g



C399



FLAT JACKS. Tests on brickworks

Determination of the resistance and deformation under load
 Evaluation of the tensile stress
 Measurement of the elastic modulus and breaking load

The complete test is developed in two steps:

DETERMINATION OF THE STATIC LOAD (TENSILE STATUS)

One flat jack is used.

Two datum points are fixed across a mortar joint and the distance between the points is measured.

Successively a horizontal cut is carried out with the suitable tool (drill, cutting saw) level with the mortar layer; and it is measured the variation of the two datum points.

The flat jack must be introduced, it is pressurized in different growing phases and the variation between the datum points is measured, by determining the static load.

DETERMINATION OF THE DEFORMATION AND RESISTANCE (IN-SITU STRESS)

Two flat jacks are used.

It must be done a second cut, parallel to the first one, level with the mortar layer; having a distance of approximately 50 cm from the first cut.

Another flat jack must be introduced.

Three couples of datum points are placed on the brickwork portion between the two cuts.

Start to pressurize the two flat jacks at growing phases.

The variation of distances of the datum points at different pressure steps allows to delineate a strength-deformation curve, obtaining elastic modulus, Poisson and breaking point values.



C358-01

RECTANGULAR FLAT JACK high deformability, max. pressure 50 bar, dimensions 400x200x4 mm. Steel sheet 0,8 mm thick Complete with nuts and groins.



C358-01

C358-05

C358-05

STOPCOCK (valve) high pressure complete with fittings, to close the oil flow in the jack and stop the pressure.

Load application:

C358-06

HYDRAULIC HAND PUMP, complete with integral reservoir with oil, to apply pressure to the jacks.

C358-15

Flexible rubber TUBE, 3 meters length, for the connection to one jack.

C358-11

N° 6 STEEL SHEETS, dimensions 400x200 mm, three pieces 1 mm thick, three pieces 1,5 mm thick

C358-11



C358-12

C358-02

SEMI-OVAL FLAT JACK ad high deformability, max. pressure 50 bar, dimensions 350x260x4 mm. Steel sheet 0,8 mm thick. Complete with nuts and groins.

C358-12

N° 6 STEEL SHEETS, dimensions 350x260 mm, three pieces 1 mm thick, three pieces 1,5 mm thick



C358-06

C358-08

C358-15

or:

C358-23N

C358-16 Flexible rubber DOUBLETUBE, 2 and 3 meters length, for the connection to two jacks.

C358-08 MANOMETER high precision 0 - 60 bar range, with fast jack, to be fixed on the pump to read the applied pressure.

Strain measurement:

C361 KIT

STRAIN GAUGE-EXTENSOMETER with mechanical strain gauge, 300 mm length

or:

C363 KIT ÷ C359 KIT

STRAIN GAUGE-EXTENSOMETER with digital strain gauge, 300 mm length

Other strain gauge models with accessories described in detail at pag. 285



As alternative to the strain gauge, the data acquisition and processing system can be used, with the following equipment:

C358-21

ELECTRONIC EXTENSOMETER, supplied with linear displacement transducer having 10 mm stroke and 0,1% linearity, fitted in a tubular anodized aluminum frame, complete with electrical cable and connector .

Span: 300 mm

Weight: approx. 300 g



C358-23N

PRESSURE TRANSDUCER, 50 bar capacity, to be fitted to the hand pump (as alternative to the manometer). Complete with fast jack to the pump, electrical cable and connector.

C405-15N

CYBER-PLUS 8 EVOLUTION "TOUCH SCREEN"

8 Channels acquisition and processing data system, 24 bit resolution.

Electronic advanced technology, "colour touch screen" 1/4VGA, high graphic performances, the unit automatically performs test and data processing. A certificate can be printed through a printer (optional) directly connected to the unit through the USB port.

The Cyber-Plus is equipped with slots for external pendrive or SD card infinite memory supports, it can be directly connected to a PC. Contained in a practical and sturdy watertight carrying case, can be powered from an electrical network 90-270V or use the internal battery and charger granting one full day on-site use. Hardware technical details: see pag 24

S337-51

CALIBRATION process between the electronic extensometer or the pressure transducer to the data acquisition unit C405-15N



← Application exemples



C376N

Pullout test apparatus

STANDARDS: EN 12504-3 / BS 1881 part 207 / UNI 9536, comparable to ASTM C900

Used to evaluate the concrete resistance as per the strength applied to extract a disc embedded into concrete. The standard equipment conforms to EN 12504-3 Specification and comprises hydraulic extraction unit 100 kN capacity with pump, precision manometer 0-100kN, bearing ring, 10 steel discs 25 mm dia. (EN 12504-3), carrying cases. Weight: 18 kg approx.

ACCESSORY:

C376-01

INSERTS, 30 mm dia. (UNI 9536) to embed.
Pack of 25 pieces.

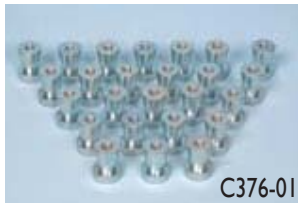

C376-01

SPARE PART:

C376-03

DISCS, 25 mm dia. (EN 12504-3) to embed.
Pack of 25 pieces.

DETERMINATION OF POWER EXTRACTION THROUGH INSERTS POST INTRODUCED, WITH FORCED AND GEOMETRICAL EXPANSION

STANDARD: UNI 10157

It's used to determine the needed power to extract from a concrete element a metallic insert that is introduced in the element by perforation.

This extraction power it's used:

- To investigate on concrete mechanic proprieties in site
- To estimate the in site concrete's compression resistance in a case of specific calibration curve

The equipment is composed of:

C376 N Pullout test apparatus

C376-10 Connecting rod furnished with bearing ring, to be used with the pull-out instrument to hook the C376-11 insert.

C376-11 Geometric expansion pull-out insert dia. 18x80 mm.
Pack of 10 inserts.

C376-12 Hardened drill beat to perform a hole as required from UNI standard and to put in a insert.

C376-13 Drill with SDS mandrin

C376-14 Striker; to put a insert into the hole

C376-15 Aspirant pump to clean the hole from detritus and dust

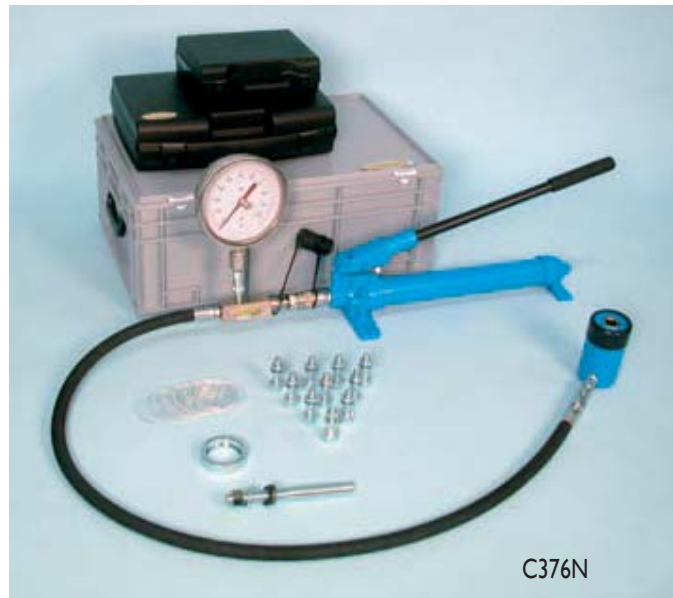

C376N



E142

Digital "pull-off" (bond) strength tester. Capacity: 16 kN

STANDARDS: EN 1542, EN 1348, EN 1015-12, EN 13687-2
NF P18-858 / BS 1881:207 / ISO 4624
EN 13963, 14496

This dynamometer measures the adhesive force and the tensile strength of two layers of materials (concrete, facing plasters, mortars, building plasters, lime etc.) and is particularly suitable for applications concerning testing repairs of any structure where the bond strength between two layers is an essential factor. Technical details, more accurate description and accessories: see pag. 330



E142



C374

Moisture meter “Surveymaster”

Used to measure the damp conditions in concrete structures, masonry, gypsum, both on surface and at depth with non-destructive method.

Measuring range: from 7,9% up to the nominal value of the 99% with +/- 0,1% accuracy.

Digital reading of values, audible alarm.

Battery operated.

Dimensions: 170x54x42 mm

Weight : 200 g approx.



C374

C374-06

Aquameter, universal moisture meter

This pocket electronic instrument measures the quantity of water in various solid materials such as: concrete, masonry, gypsum, brick, woods, mortars etc.

Using a high frequency capacitive sensor, a large volume of material (approx. 50x75x25mm) is sampled instantaneously.

Features and Benefits:

- Direct read-out of moisture content; no charts or tables required
- Resolution: +/- 0,1%
- Accuracy: +/- 0,2% at constant temperature
- Sensing field volume: approx. 90 cm³
- Program mode on concrete, masonry, gypsum, brick, most woods available for maximum accuracy, with special user calibrated mode and averaging function.
- No prongs, probes or holes to be drilled

Typical Applications:

- Locate leaking pipes in walls and floors
- Locate seeping water in basements and masonry tanks
- Check moisture level of materials before applying coatings or adhesives
- Curing condition of wood, stucco and other construction materials

Powered by: battery 9V

Dimensions: 110x70x50 mm

Weight: 250 g approx.

C374-06



A028

Carbide meter for surface dampness

For the rapid and accurate determination of moisture content. The sample is drilled or scraped from the surface and introduced into the bottle with the carbide reagent.

The meter is suitable for moisture tests on sand, aggregates, soil etc. It is possible to vary the sample weight from 3 to 100 g for the complete reaction between sample and carbide with accurate moisture measurements from 0 to over the 20%

The glass ampoule containing the calcium carbide is broken when the bottle is closed and shaken, granting better accuracy to the test. The instrument comprises the testing bottle with manometer; small balance, 20 ampoules of reagent, accessories, case.

Dimensions: 520x340x140 mm. Weight: 6 kg approx.

SPARE-PART:

A028-11

Carbide Ampoules (pack of 100)



A028

C375-02

Carbonation test

STANDARD: EN 13295

The test allows the measurement of the depth of carbonation through the surface of concrete.

The set consists of :

- two washing bottles capacity 500 cc. containing phenolphthalein solution and distilled water;
- depth measuring gauge.

The surface of the concrete specimen under test is sprayed with phenolphthalein solution to detect the loss of alkalinity associated with carbonation.

The risk of carbonation induced corrosion can be measured, if correlated with the concrete cover to reinforcement. Weight: 1,5 kg



C375-02



C375-01

Chloride field test system

STANDARD: ASTM C114 (conforms to AASHTO T260)

The determination of the chloride ion concentration in concrete is essential in assessing the need for maintenance on, for example, bridge decks and parking structures. The test can also be used to ensure that materials used in new construction are free from potentially harmful chloride ion levels.

With this method, the concentration of acid soluble chlorides is measured. In most cases this is equivalent to total chloride concentration.

Features and Benefits:

- Fast results within minutes at the site
- Low cost per sample compared to laboratory testing
- Accurate results are comparable to laboratory testing
- Covers wide range from 0,002% to 2% chloride by weight
- Automatic compensation for changes in ambient temperature
- Digital display for direct reading of lbs./cu.yd. and percentage of chloride by weight

The test system includes:

- Electronic meter; high impedance with temperature compensation and microprocessor for direct conversion to percentage of chloride. Battery powered.
- Chloride combination electrode with temperature sensor
- 12 jars each with 20 ml of extraction liquid
- 5 jars of coloured calibration liquid
- Scale for 3 g samples weighing, accessories, carrying case

Weight: 5 kg approx.

C375-10 KIT

Air and water permeability of concrete FIGG TECHNIQUE

The ingress of air and moisture into the concrete can cause corrosion of the steel reinforcement and lead to a deterioration in concrete strength.

Therefore, a measure of the ease of movement of liquids and gases through the surface layer of the concrete is a better method of assessing the soundness and expected life of concrete than strength alone.

Permeability is recognized as being the most important parameter in assessing concrete durability.

The depth test is performed by drilling a hole 10 mm diameter x 40 mm deep, and plugged with a silicone rubber plug.

An hypodermic needle is passed into the stopper; the water permeability test is performed by measuring the time of absorption needed by the water introduced into the void by pressure.

For the air permeability test, a vacuum pressure is created in the void, and the time needed to rise this pressure is measured.

Surface permeability tests can be carried out by clamping a stainless steel chamber on the smooth surface of the concrete.



C375-10 KIT



C375-01

The equipment comprises: manual vacuum pump, digital pressure measuring system, stainless steel chamber for surface measurements, 25 silicone rubber plugs, clamping pliers, drill bits, anchors, accessories. The whole contained in carrying case.

Dimensions: 430x300x150 mm

Weight: 6 kg approx.

SPARE-PART:

C375-11

Silicone rubber plugs.

Pack of 25 pcs.

RAPID CHLORIDE PERMEABILITY OF CONCRETE



C378

Chloride Ion penetration meter

STANDARDS: ASTM C1202, ASTM C1760 / AASHTO T277

Laboratory test device for the measurement of the resistance of the concrete against the penetration of chloride.

The measurement data can be used to estimate the chloride diffusion coefficient of concrete for the service life prediction and design of concrete structures as well as the durability-based quality control of concrete.



C378

section C



291

Applications

The device can be used for testing the durability of concrete exposed to chloride-contaminated environment including:

- Concrete's ability to resist chloride ion penetration (ASTM C1202, AASHTO T277).
- Bulk electrical conductivity of concrete (ASTM C1760).
- Performance-based quality control of concrete.
- Estimation of chloride diffusion coefficient of concrete.
- Estimation of chloride migration coefficient of concrete
- Service life design of concrete structures.
- Estimation of the remaining life of concrete structures.

Features

The following are unique features of this device:

- Stand alone operation.
- Easy-to-assemble.
- Accurate (+/- 0.1 mA)
- Flexible logging interval time (1 to 10 min)
- Automatic temperature control system.
- Four measurement channels.
- User-friendly PC software.
- Customizable setup.
- USB connection to computer.

Compliance:

- The only instrument in the market that meets the specifications of ASTM and AASHTO Standard for sample cell.
 - Electrical safety certification mark for use in concrete laboratories.
- Supplied complete with set of test cells, temperature sensors, test cables, power cord, USB cable, communication software, user manual.

Specifications:

Type	Value
Applied voltage (ASTM C1202 test)	60 +/- 0.1 V
Range of current measurement	0 - 500 mA +/-0.1, +/-0.2%
Temperature measurement range	0 - 100 +/- 1°C
Operating temperature	15°C - 45°C
Operating humidity	30% - 80%
Measurement channel	4
Short circuit protection system	Yes
Measurement display on LCD	Yes
Remaining time display on LCD	Yes
LCD display area	65 x 33 mm
Operating voltage:	100-240V 50/60Hz 1ph
Dimensions of device	280 x 240 x 104 mm
Weight	2 kg

ACCESSORY:

C378-01

VACUUM PUMP + DESSICATOR and accessories to saturate the specimen with water (required by ASTM C1202).

MATTEST

REBOUND CONCRETE TEST HAMMERS

STANDARDS: EN 12504: Part 2 / ASTM C805 / UNI 9189 / DIN 1048
BS 1881:202 / NF P18-417 / UNE 83307

Designed to perform non-destructive tests on concrete structures, it gives an immediate indication of the compressive strength of the concrete using the calibration curve supplied with.

MODELS:

C380

Concrete test hammer, Matest model

Spring impact energy 0,225 mkg. (2,207 Joule or Nm)
Suitable for finished concrete structures and buildings having strength resistances from 10 to 70 N/sq.mm. **This concrete test hammer, entirely produced by Matest, has aluminium frame, and thanks to its very accurate manufacture processing and selected components ensures high precision test results in the time.**

The top quality test hammer available on the market.

Supplied complete with calibration curve chart in N/mm² (Mpa) values, abrasive stone, carrying case.

Dimensions with the case: 330x100x100 mm

Weight: 2 kg



C380



C380 WITH CASE

C380-01

Concrete test hammer, Matest model

Exactly the same to mod. C380, but with calibration curve chart in Psi values as requested by ASTM Specifications.

C381

Concrete test hammer, Matest model

Similar to mod. C380, but with impact energy of 0,735 Joule (Nm).
Ideal to test small sized, sensitive and thin walled materials.
Suitable to test also rock core samples.



C381

C390

Anvil

STANDARD: EN 12504:2

Used for the verification of the calibration of the concrete test hammers. Special steel alloy made.
Dimensions: dia. 150 by 320 mm.
Weight: 16 kg

NOTE:

The EN 12504:2 Specification requires obligatory the use of the anvil for the hammer tests.

The Standard specifies:

- Before a sequence of tests on a concrete surface, take and record readings using the steel reference anvil and check to ensure that they are within the range recommended by the manufacturer. If they are not, clean and/or adjust the hammer.



C380

C390

- After tests, take readings using the steel anvil, record them and compare them with those taken prior to the test. If the results differ, clean and/or adjust the hammer and repeat the test.

Original "Schmidt" test hammers

C382

Standard model "N" for normal concrete casting.
Impact energy 2,207 Nm

C383

"NR" model; same as C382 model, but having an automatic incorporated device recording on diagram the impact values

C383-01 Spare roll recording paper for C383 (pack of 5)



C383-10

Silver Schmidt

Digital concrete test hammer: Impact energy: 2,207 Nm.

C383-10



C382



C383



C386 N

Digital Concrete Test Hammer with microprocessor, MATEST model

STANDARDS: EN 12504:Part 2 / ASTM C805 / BS 1881:202 / NF P18-417 / DIN 1048 / UNI 9189 / UNE 83307

This digital concrete test hammer, microprocessor operated, entirely designed and manufactured by Matest with advanced technology, performs basic concrete testing with continuous automatic recording of all parameters in accordance with EN 12504-2 Specifications, register and process data and then transfer them to a PC. The unit consists of the standard mechanical model C380, but equipped with an electronic transducer that measures the rebound values and supplies automatically the results on a graphic display.

During test performing:

- Shows index value
- Shows average index value
- Allows to select measuring system in MpA or Psi
- Shows numbers of performed rebounds
- Shows date and time
- Identifies tested element
- Identifies automatically and shows rebound angle
- Shows battery life

Main features:

- Possibility to store, display on graphic LCD 64x124 and download data to PC over 15000 tests
- Automatic statistical processing and readings
- Automatic conversion of rebound index to equivalent compression strength in psi, N/mm², kg/cm²
- High accuracy and resolution

Technical specifications:

- Impact energy: 2,207 Joule (Nm)
- Measuring range: 10 – 120 N/mm²
- Interface: USB
- Power source: 6 rechargeable batteries AA NiMh 2400mA/hour
- Battery life: 60 hours with automatic shut down
- Operating temperature: -10°C +60°C

Supplied complete with data transfer software, data transfer USB cable, battery charger, abrasive stone, carrying case

Dimensions with case: 330x180x120 mm

Weight: 3 kg



C386 N WITH CASE



C386 N

Note:

The calibration anvil is the same (mod. C390) of the standard hammers.

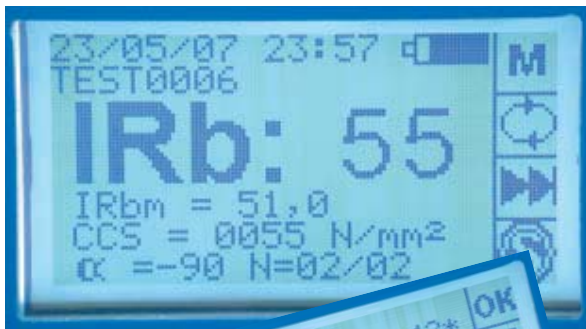

The digital Matest test hammer is suitable to be connected to the Ultrasonic Tester “high performance” mod. C372N (see pag. 296) for “combined ultrasonic and rebound tests with automatic data acquisition, processing and store of the results”



C386 N + C372N

C373-10N

Cross Hole Ultrasonic System, TWO channels, for deep foundations

STANDARD: ASTM D6760-02

The Cross-hole Sonic Logging (CSL) method is used to perform high-resolution quality control on deep foundations.

The system uses an ultrasonic wave sent from an emitter to a receiver while both are pulled through water-filled access tubes embedded in the concrete. The measured arrival time and energy are directly related to concrete quality.

The control unit must be connected via USB port standard to a regular notebook computer or Tablet PC (not included) on which, should be installed the software (included) for testing, analysis and real time reporting in 2-D Tomography.

Easy to use: the user-friendly software makes it possible to master the instrument in less than a day. No additional expensive training required. Powerful tomography features are available.

section C



294

SPECIFICATIONS:

- Housing: rugged, environment-proof, water-resistant housing.
- Temperature range: -25 to 60 °C (operating), -40 to 70 °C (storage).
- Transducers: dual-purpose transceivers, 50 kHz nominal, pressure-tested housing, 25 mm diameter.
- Cables: detachable heavy-duty polyurethane wound on reel.
- Cable length: 50 m (100 m and 150 m cables are available upon request).
- Sampling rate: 500 kHz (2 μs resolution).
- Gain: 8 level automatic gain control (AGC).
- Depth meters: two 24-bit counters, <0.1% error.
- Pile measuring range: 1 to 145 m
- Tube spacing: up to 4 m in good concrete.
- Productivity: up to 3000 m/Day by a single operator.
- Memory storage: unlimited.
- PC minimum requirements: Windows 2000/XP, 300 MHz, 128 Mb, 800x600 resolution (not included).
- Reporting: arrival time, energy and wave speed curves, "waterfall" presentation, dual presentation, fuzzy-logic, tomography.
- The package includes: a computerized central unit, two ultrasonic transducers, two 50 m cable reels, two depth meter pulleys, cables and AC power adapter, and the software.
- Language: Multi-lingual user-interface and reporting.
- Power supply: internal rechargeable lithium ion battery (two days of typical use), external 100-240V AC (operation/charging).
- Dimensions: 430x325x105 mm (instrument only).
- Weight: 3.8 kg (instrument only).

ACCESSORIES:

C373-12 Two 100 m cable reels (instead of 50 m standard ones)

C373-13 Two 150 m cable reels (instead of 50 m standard ones)



ULTRASONIC PULSE VELOCITY TESTERS

STANDARDS: EN 12504 part. 4 / ASTM C597 / BS 1881:203 / UNI 9524 / NF P18-418 / UNE 83308

Used to determine the presence of faults, voids, cracks etc., in in-situ or precast concrete and for longterm monitoring of structures subject to environmental conditions.

They give data concerning the homogeneity of the concrete, by generating pulses of sound into the concrete and measuring the time the sound to travel from the transmitter probe to the receiver probe through the material. Furthermore it is possible to have indicative data about the modulus of dynamic elasticity, and strength of the concrete.

AVAILABLE MODELS:

C369N

Ultrasonic pulse velocity tester "high technology"

- Measuring range: 0 - 3000 μ s - accuracy +/- 0,1 μ s
- Selection of the ultrasonic pulse amplitude adjustable from 250 to 1000V
- Measurement of the required time by the ultrasonic pulse to go through the tested material.
- Single or continuous acquisition mode with automatic or manual saving.
- Zero calibration with depuration of the time for the pulse to go through the probes.
- Calibration of a defined time value.
- Capacity of data acquisition, processing and filing of the test data up to 30.000 samples.
- Interface mini USB for PC connection.
- Two outlets for connection to the oscilloscope.
- Languages: English, French, German, Spanish, Italian.
- The use of the instrument is made easy because it is based on the user-friendly system.

The standard appliance includes:

- The instrument in basic configuration in a practical palmer container.
- Two 55kHz probes with connection cables.
- Calibrating cylinder and contact paste.
- Battery rechargeable pack NiMh 4,8V > 2000m/A with low battery condition alarm.
- Anti shock case holding the unit and the accessories.
- External feeder 230V and battery charger 12V 500m/A.

Case dimensions: 400x340x110mm

Weight: 2 kg approx.

ACCESSORIES:

- C370-08** EXPONENTIAL TRANSMITTING/RECEIVING PROBES (couple), 55 kHz Nominal Frequency.
- C372-10** TRANSMITTING/RECEIVING PROBES (couple), 150 kHz Nominal Frequency, indicated for homogeneous, compact, high density concrete.
- C372-11** TRANSMITTING/RECEIVING PROBES (couple), 24 kHz Nominal Frequency, indicated for heterogeneous, low density concrete.
- C370-10** COUPLE OF CABLES (each 10 mt. long) to connect the probes to the tester. Used to test voluminous/large structures.



C369N

C369N
with case



SPARE-PARTS:

- C370-02** TRANSMITTING/RECEIVING PROBES (couple), 55 kHz
- C370-06** COUPLE OF CABLES (each 3,5 mt. long) to connect the probes to the tester.
- C370-07** Tube of grease to better coupling the probes to the material under test.



C372N

Ultrasonic pulse velocity tester, “high performance” with microprocessor for combined ultrasonic and rebound hammer data acquisition and processing.

STANDARDS: EN 12504: part 4 / BS 1881:203 / ASTM C597 / NF P18-418 / UNE 83308 / UNI 7997, 9189, 9524

section C



296

This is an instrument using the most modern technologies; it has a ¼ VGA colour touch screen, 64 MB, Compact Flash interface, SD card, USB, RS232, RS485, working system Windows CE with the possibility to manage, EXCEL, WORD, PPT files etc.

Ultrasonic tests:

The appliance allows measuring the ultrasonic impulse speed inside the material (by knowing the distance between the probes). It measures the distance between the probes (by knowing the speed of the ultrasonic impulse to go through the tested material). It measures the required time by the ultrasonic impulse to go through the tested material.

Young's modulus is also measured (by knowing the distance between the probes and the density of the tested material).

Calculation of the crack depth.

Zero calibration with depuration of the time for the impulse to go through the probes.

Calibration of a defined time value.

Advance function for research purposes:

- Selection of the transmission frequency of the impulse.
- Selection of the impulse amplitude.

Infinite filing capacity of the test dates and the graph tracing of the tests on SD card or Compact Flash extractable and expandable.

RS232 or RS485 or USB interface for PC or printer connection.

Time measuring from 0 to 9999,9 µS

Resolution: 0,1 µS

Possibility to use the instrument with two exponential probes, or with one standard probe and one exponential probe.

The use of the appliance is made easy because it is based on the Palmer PC and Windows CE way of working, it allows using the user knowledge of the classic personal computer and its softwares.

Possibility to connect the instrument to internet for consultations or extractions, like a common PC.

Possibility to visualise the shape of the transmitting wave while it goes through the material checked, by transforming the instrument into a real oscilloscope with the option “Scope” mode.

Combined ultrasonic and rebound hammer determination (sonreb method):

The C372N ultrasonic tester houses an integral data logger for data acquisition, processing and store of rebound hammer values.

The acquisition of the rebound values is performed with manual or automatic mode.

a) Manual mode:

Rebound values measured with a standard concrete hammer are manually input into the ultrasonic Tester.

b) Automatic mode:

The digital Matest test hammer mod C386N is directly connected to the ultrasonic tester through a cable. The measured rebound values are automatically transmitted to the C372N tester.

The measures of the velocity of ultrasonic pulses and the rebound values are automatically stored and processed, giving estimates of dynamic modulus of elasticity and Poisson's Ratio, and providing informations on possible voids, cracks and strength of the structure. Through mathematical formulas it is possible to evaluate the compressive strength of the concrete, useful to estimate formwork striking times.

The combined test allow to rectify different inaccuracies that are typical of the simple rebound hammer test, and obtaining estimates on the compressive strength of the concrete, that cannot be obtained with the ultrasonic test, granting high accuracy and reliability of the results.

The standard appliance includes:

- Instrument in basic configuration (x-scale 400MHz, 64MB Flash Memory, 64 MB Ram) in a practical and elegant palmer container.
- Two 55 kHz probes with connecting cables.
- Calibrating cylinder and contact paste
- Strong anti shock case holding the instrument and the accessories.
- Battery pack Li-Ion 11,1V 3000mA.h
- External feeder 230V/24V and battery charger

Dimensions: 400x300x180 mm.

Weight : 3 kg.



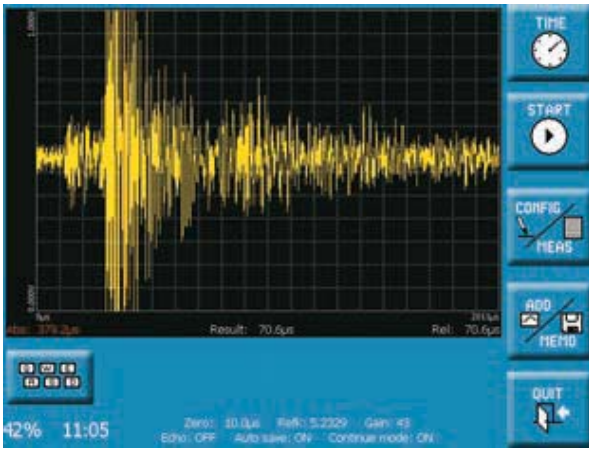

Display of graphic function



C386 N + C372 N



Display of internet function



Electronic card: detail



C372 N with case

ACCESSORIES:

- C370-08** EXPONENTIAL TRANSMITTING/RECEIVING PROBES (couple), 55 kHz Nominal Frequency.
- C372-10** TRANSMITTING/RECEIVING PROBES (couple), 150 kHz Nominal Frequency, indicated for homogeneous, compact, high density concrete.
- C372-11** TRANSMITTING/RECEIVING PROBES (couple), 24 kHz Nominal Frequency, indicated for heterogeneous, low density concrete.
- C370-09** COUPLE OF CABLES (each 10 mt. long) to connect the probes to the tester. Used to test voluminous/large structures.



C372-10

SPARE PARTS:

- C370-02** TRANSMITTING/RECEIVING PROBES (couple), 55 kHz
- C370-04** COUPLE OF CABLES (each 3,5 mt. long) to connect the probes to the tester.
- C370-07** Tube of grease to better coupling the probes to the material under test.



C370-02

C370-08



C393

Resonance frequency meter

FOR THE DETERMINATION OF THE RESONANT FREQUENCY OF CONCRETE

STANDARDS: ASTM C215, C666 / BS 1881:209 / NF P18-414
UNI 9771

The unit measures the resonant frequencies of the three different modes of vibration:

- Longitudinal, transverse (flexural) and torsional.

From these, the following material characteristics, non destructively, can be calculated:

- young's modulus of elasticity,
- modulus of rigidity, and
- poisson's ratio.

Available for specimen sizes up to 150 mm cross section dimension, and from 45 mm to 700 mm in length.

Automatic identification of the resonance frequency. Large easy to view display for data analysis of time domain and frequency spectrum signals.

Data can be stored and uploaded to a PC for further analysis and inclusion in report.

Fast and easy to use system.

The principle used in this meter is based upon the determination

of the fundamental resonant frequency of vibration of a specimen generated by an impact and sensed by an accelerometer. The frequency spectrum is computed and displayed by the meter.

Durability of concrete:

The determination of flexural resonance is very important when studying the degradation of concrete under accelerated freezing and thawing cycles and aggressive environments on concrete specimens. The advantages of resonance methods are:

- Test can be repeated over a very long period on the same specimen; the number of test specimens required is therefore greatly reduced.
- The results obtained with the resonance method on the same specimen are more reproducible than those obtained with non destructive tests and groups of specimens.

Specifications:

- Frequency range: 10 Hz to 20 kHz
- Sampling rate: 20 kHz or 40 kHz
- Accelerometer sensitivity: 9.60 mV/g (0.979 mV/ms²)
- Battery 12V, 4-10 hours continuous use.
- Display: 320 by 240; backlit for daylight use.
- Storage: 200 plus readings.
- Software: Windows compatible 9x/me 32 MB Ram.
- Impactors: set of 6 hardened steel balls.

The standard supply includes:

- electronic main unit.
 - standard bench with its accessories.
 - accelerometer with cable.
 - hardened steel balls set.
- Weight: 30 kg approx.



C393

C394

AutoScan CTE - Coefficient of Thermal Expansion of concrete

STANDARD: AASHTO T336-11

An advanced and automatic method and device for measuring the Coefficient of Thermal Expansion of concrete cores. All functions are completely automatic, including accurate controls for heating, cooling and height measurements. The product is designed to accumulate all height measurements without surface treatments, special holding jigs or other accessories. All height measurements are accomplished by a high precision LVDT. The height measurements of the sample are taken and averaged over a range of specified temperatures. CTE values are automatically calculated and displayed when the test cycle is completed. The product is completely self-contained and operates with easy to understand graphical interface software.

LVDT range: ± 1 mm

Temperature range: 10 to 50 °C

Temperature accuracy: ± 1 °C

Power supply: 230V 1ph 50Hz 550W

Dimensions: 480x480x600 mm

Weight: 11 kg



C394



COVER TO REINFORCEMENT

For determining the presence, position, direction, depth and diameter of steel reinforcement bars in concrete structures.

STANDARDS: BS 1881:204 - DIN 1045

C403-01

Profoscope

Versatile, fully-integrated rebar detector and cover meter with a unique real-time rebar visualization allowing the user to actually "SEE" the location of the rebar beneath the concrete surface to a maximum deep of 180 mm.

This is coupled with rebar-proximity indicators and optical and acoustical locating aids.

Rebar diameter can also be estimated within the specified testing range.

The Profoscope combines these unique features in a compact, light device that allows the user to operate this rebar detector with one hand making the task of locating rebars a simple and efficient process.

In addition the unit convinces through its intuitive user interface making rebar detection easy.



FEATURES:

- Visual indication of rebars in close proximity.
- Ability to identify the mid-point between rebars as well as the orientation of rebars.
- Optical and acoustical indication of rebar location and minimum cover alert.
- Neighboring bar correction.
- Cordless and single handed operation.
- Icon-based language independent menus.
- Start-up test kit allows user to familiarize with all functions in a comfortable environment, wasting no time on site.

C396N

Profometer PM-600

This new generation Profometer Touchscreen unit offers real time control over the measurement procedure for the precise and non-destructive detection of rebar locations and measurement of the concrete cover and rebar diameters directly on site.

The instrument comes along with the Universal Probe with integrated spot probe for measurements in corners, limited spaces and congested rebar arrangements.

Deep measuring range: up to 175 mm

Measurement accuracy: from ± 1 to ± 4 mm

Screen: 7" color; 800x480 pixel.

Dia. accuracy measurement: ± 1 mm

Dia. measuring range: up to 63 mm

Weight: 1600 g



C397N

Profometer PM-630

Sophisticated advanced meter extending the application range of the Profometer PM-600 with the Line and Scan Modes and an extensive choice of statistical views.

Specially suitable to measuring large areas, long lines, inspecting tunnels, retaining walls, bridge slabs etc.

The link software allows the download of the saved data to a PC for analysis.



C403-02

Profoscope+ (plus)

Same features of mod. C403-01, but additionally offers the innovative memory function for automatic data acquisition, by eliminating the manual measurements of a test series, saving time and unnecessary source of errors.



C411

Canin

CORROSION ANALYSING INSTRUMENT

STANDARDS: UNI 9535 / ASTM C876 / BS 1881:201

For the non-destructive detection of corrosion in the reinforcement bars of concrete building elements.

The large display, just 9 keys for simple operation using menu technique and intelligent memory render Canin a unique instrument worldwide.

120.000 measurements can be stored in the intelligent memory and called up with the cursor keys. A measuring surface of more than 4000 sq.mt. can be managed with the large memory. Standard supply includes one bar electrode, RS 232, integrated software for printer; cables, copper sulphate, carrying case.

Dimensions: 300x330x100 mm

Weight: 5 kg

section C



300

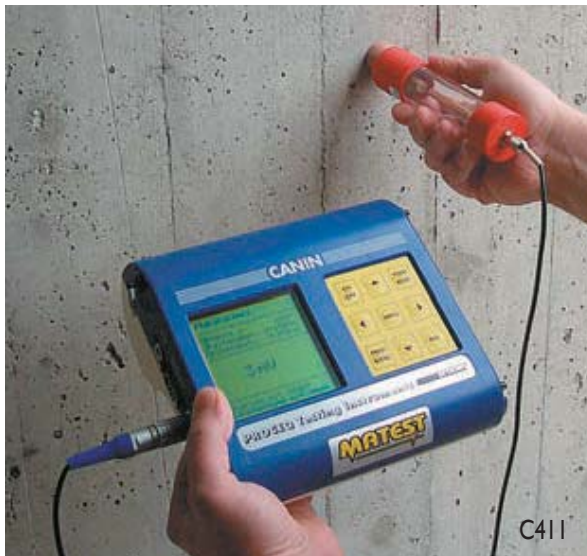

C411

EXTENSIONS:

C411-05

ONE-WHEEL ELECTRODE, for fast scanning of large areas.

C411-06

FOUR-WHEEL ELECTRODE, for maximum measurement speed on large areas.



C411-05

C412-01

Digital resistivity 2-probe array meter

Used for assessing the probable rate of corrosion in reinforcing bars with the electric resistivity measurement method.

A highly permeable concrete has a high conductivity with reduced electrical resistance.

The knowledge of the electrical resistance of a concrete allows to measure the possible rate of corrosion of steel reinforced bars embedded in it.

The test is simple to perform and requires only two 6,5 mm diameter holes drilled to a depth of 8 mm. Inject a small amount of conductive gel into each hole and insert the probes. The resistivity value is immediately displayed.

- Measuring range: 0,5 to 20 kΩ cm, with 0.1 kΩ resolution.

- 2-probe array spacing: 5 cm

- Display: LCD 4 ¼ digit

- Battery operated with 100 hours operating time

The instrument is supplied complete with drill bit, gel, template, accessories, carrying case.

Dimensions: 400x270x130mm

Total weight: 4 kg

SPARE PART:

C412-II

Tube of conductive gel.



C412-01

C414

Cor Map

A SIMPLE METHOD FOR IDENTIFYING AREAS OF PROBABLE REBAR CORROSION IN CONCRETE STRUCTURES

STANDARDS: ASTM C876 / BS 1881:201 / SIA 2006

UNICO 174 / DGZfP B3

Features and Benefits:

- Detachable electrode extension pieces (41 cm long), facilitate measurements in hard to reach locations.

- High impedance digital meter is designed for tough field conditions.

- Easy to use, supplied complete.



C414 detail

ACCESSORY:

C414-01

REFERENCE ELECTRODE, including copper sulphate reservoir.



C414 complete set

NEW

C410 Windsor HP probe digital system

STANDARDS: ASTM C803 / BS 1881:207 / ACI 347

To evaluate the compressive strength of concrete in place with the penetration method. Non destructive test. It is fast, accurate and simple to perform. The five-minute test does not weaken the structure. Comparison between test results using this method and destructive tests shows a variance normally within 3% from each other. The method requires a pistol-like device which is loaded with a small explosive charge and metal probe. The charge is precisely measured to give a consistent firing force. By pulling the trigger the probe is fired into the concrete.



Standard equipment consist of:
 - driven unit
 - digital measuring unit with memory for data storage to PC unloading
 - accessories and carrying case.

Probes and power charges **"are not included"** and must be ordered separately.

Dimensions:
 500x400x200 mm
 Weight : 16 kg



ACCESSORIES: C410 with case and accessories

C410-01

SILVER PROBES used for high performance concrete with strength up to 17000 PSI (110 MPa).

Complete with probes and power loads.

Pack of 75 probe Kit.

C410-02

GOLDEN PROBES recommended for light weight concrete.

Complete with probes and power loads.

Pack of 75 probe kit.



C403-10

C410-10 Windsor pin penetrometer

PENETRATION RESISTANCE

STANDARD: ASTM C803

This portable instrument is suitable to evaluate the concrete strength and mortar joints of existing structures up to 37 Mpa.

The unit can test also polymer concrete and patching compound.

The test is performed by penetrating a steel pin into the concrete.

The pin can be reused.

Safe to use: no explosive charge is required.

Ideal for quality control on precast elements, pipes, brick slabs etc.

The test is based on the depth penetration principle which is inversely proportional to the compression strength.

The spring system of the unit penetrates the steel pin into the concrete, and the micrometer (supplied with) measures the reached depth penetration.

This value is compared with previously prepared chart, or with provided charts for typical concrete and mortar.

The penetrometer is supplied complete with accessories, portable carrying case.

Dimensions: 420x310x150mm

Weight: 8 kg approx



C410-10

C403-10 Deep scanning metal detector up to 150mm

This locator finds and scans, through solid concrete, steel rebars and metallic materials like pipes, electric cables, junction boxes, metal studs and frames up to 150mm deep.

It scans and differentiates steel rebars from other metallic materials like copper pipes.

It differentiates magnetic metals from non magnetic ones.

This detector is an essential device for building contractors, remodelers, electricians, plumbers.

Accuracy: rebars or pipes 14mm dia. with minimum grid space of 152mm are scanned within 13mm tolerance.

Depth: 152 +/- 25mm

N° 1 alkaline battery 9V (not included) for one year use.

Dimensions: 250x110x62mm

Weight: 300g approx.





C405-10
Deflectometer with telescopic tubular displacement transducer.

Used to determine the deflection under known loads of bridges, ceilings or any suspended structure.

This instrument grants very accurate and reliable test results with data acquisition through Cyber-Plus 8 Evolution mod. C405-15N.

One telescopic deflectometer consists of:

- Aluminium telescopic tubular anodized frame having 1080 mm minimum height and 3120 mm maximum extension.
- Linear potentiometric displacement transducer with spring system, fixed on the base of the telescopic tubular frame, with measurements either in compression or tension, +/- 50 mm stroke and 0,01 mm resolution.
- Stainless steel chain, 10 m long for measurements over 3 m.
- Stainless steel base for anchoring the tubular with ballast, hook, accessories.
- Carrying case.

Weight: 2 kg

NOTE: Three deflectometers are recommended to correctly perform a test.

C405-15N
Cyber-plus 8 Evolution "Touch Screen"

8 Channels acquisition and processing data system, 24 bit resolution. Electronic advanced technology, "colour touch screen" 1/4VGA, high graphic performances, the unit automatically performs test and data processing. A certificate can be printed through a printer (optional) directly connected to the unit through the USB port

The Cyber-Plus is equipped with slots for external pendrive or SD card infinite memory supports, it can be directly connected to a PC. Contained in a practical and sturdy watertight carrying case, can be powered from an electrical network 90-270V or use the internal battery and charger granting one full day on-site use.

Hardware technical details: see pag 24

S337-51
CALIBRATION process of one deflectometer with the data acquisition unit C405-15N.

ACCESSORIES:

Cisterns for load tests

Made with flexible polystyrene covered in PVC, they are used to load the structure so to measure its deflection.

Supplied with connector, flexible pipe and spherical valve.

Available in different capacities:

Model	Capacity litres	Dimensions cm	Weight kg
C405-24	1000	240 x 145	10
C405-25	2500	280 x 240	16
C405-26	5000	400 x 240	25
C405-27	10000	490 x 340	40



C405-30
Litre-counter, electronic, for cisterns.

It measures and displays the quantity of water.

Accuracy: +/- 1%

Feeding, AAA standard batteries

Weight: 2 kg



SPARE-PART:

C405-20 CHAIN, 10 m long, stainless steel, for measurements over 13 m.

Deflectometers, swing-arm model

Used to determine the deflection on bridges, ceilings or any suspended structure. Possibility to use the deflectometer in pressure or traction, and direct reading on the dial gauge. Available in “one” or “three” sets, to be completed with dial gauges stroke from 10 to 50 mm.

One deflectometer set comprises:

Swing-arm with clamp for complete orientation in any position, inextensible wire coil 20 metres long, plumb weight, carrying case. Supplied “without” dial gauge to be ordered separately (see accessories).

MODELS:

- C405N** n° 1 set of deflectometer (without dial gauge)
- C406N** n° 3 sets of deflectometers (without dial gauges)

ACCESSORIES:

- S376** Dial gauge 10 mm stroke x 0,01 mm sens.
- S377** Dial gauge 25 mm stroke x 0,01 mm sens.
- S378** Dial gauge 30 mm stroke x 0,01 mm sens.
- S379** Dial gauge 50 mm stroke x 0,01 mm sens.

SPARE:

- C407-02** Inextensible wire coil, 20 metres long



CRACK WIDTH GAUGES

Used for monitoring, measuring and recording the crack width of a building structure.

Internal or external use, manufactured in vandal resistant polycarbonate, complete with crack record card each gauge to simplify monitoring, they are suitable for vertical and horizontal movement measurements.

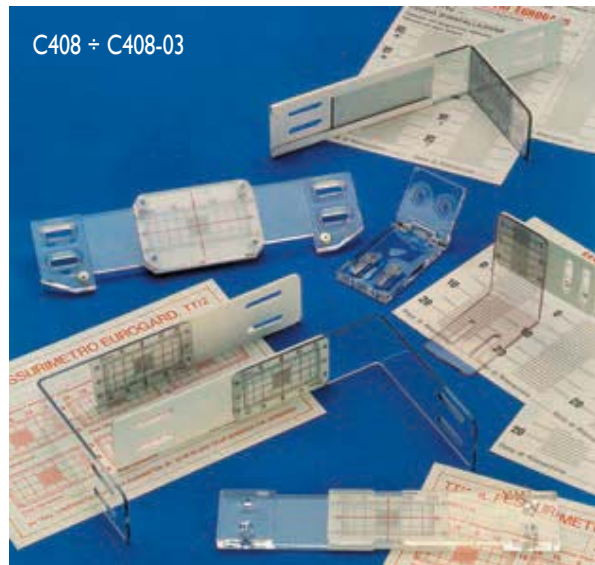

MODELS:

- C408** CRACK WIDTH GAUGE FOR WALLS, to monitor vertical and horizontal movements, also simultaneous, on a plane surface. Pack of 5 pieces.
- C408-01** CRACK WIDTH GAUGE FOR CORNERS, to monitor corner cracks with bidirectional movements, also simultaneous. Pack of 5 pieces.
- C408-02** CRACK WIDTH GAUGE FOR FLOORS, to monitor floor settlements to a wall, column etc. Pack of 5 pieces.
- C408-03** CRACK WIDTH GAUGE FOR DIFFERENCE IN LEVELS, to monitor the loss of levelness of any cracked surface. Pack of 5 pieces.

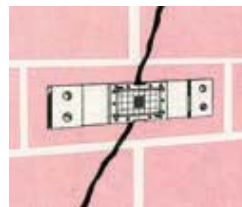

C430

Automatic concrete water permeability apparatus at four cells

This fully automatic apparatus is designed to perform water permeability tests on cubic concrete specimens max. 150 mm side and cylinder specimens max. 160 mm diameter. The specimens are submitted to hydrostatic stress for a pre-set period. The water permeated through the test specimen is directly collected and measured into a graduated cylinder.

It is therefore possible to determine the permeability coefficient in cm/sec. (Darcy coefficient) by the following formula:

$$K = \frac{cc \times h}{A \times t \times P}$$

where: cc = permeated water in cm³
 h = height of the specimen (cm)
 A = surface area of the specimen (sq. cm.)
 t = time to permeate (sec.)
 P = hydrostatic pressure in cm. of water column

The equipment consists of a strong metallic frame holding four cells which are hot-galvanized for anti-corrosion protection. Each cell includes a pressure control manometer. A re-chargeable compensation plenum chamber is included as part of the test.

The pressure is adjustable from 0 to 30 bar and it is supplied by an automatic pump of variable supply, to achieve the most suitable installation for the specimen under test.

Water feed is direct from water inlet.

Seal pressure obtained through special and practical seal devices which maintain and simplify the use of the machine.

It is possible to use one or more cells together, and specimens also of different size (cubes/cylinders).

The specimen's sealing system is achieved through a practical and speedy, user-friendly device.

Supplied complete with four cells, four graduated cylinders, epoxy resin and accessories. The "sealing devices are not included" in the standard package and must be ordered separately.

Power supply: 230V 1 ph 50 Hz

Dimensions: 2500x500x1300 mm

Weight: 240 kg

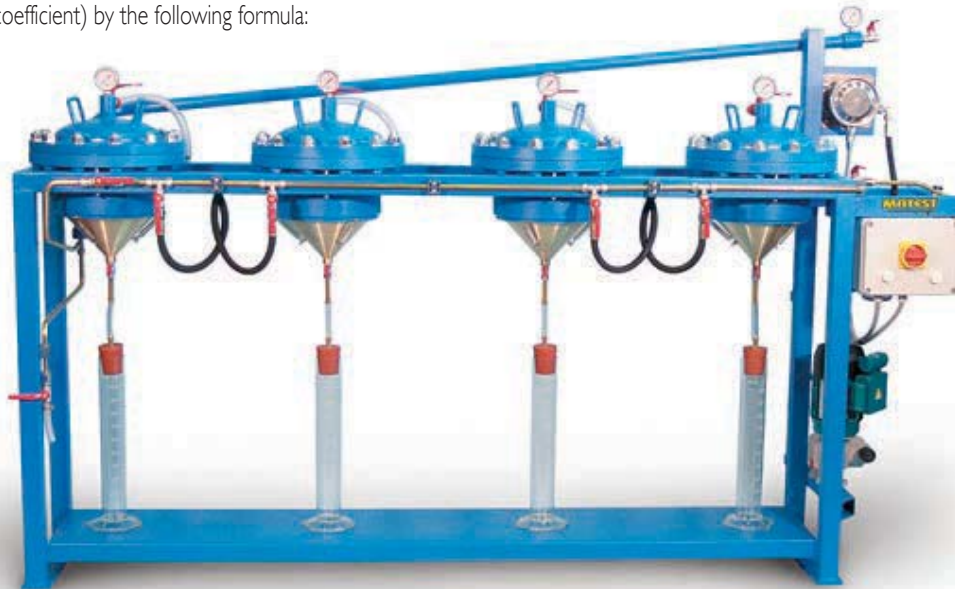

C430

"NEEDED" ACCESSORIES:

Sealing device, complete with rubber latex packing which is between the two hot-galvanized steel collars. Complete with bolts.

MODELS:

- C432-01** Sealing device for cubes 100 mm side
- C432-02** Sealing device for cubes 150 mm side
- C432-04** Sealing device for cylinders dia. 100 mm
- C432-05** Sealing device for cylinders dia. 150 mm
- C432-06** Sealing device for cylinders dia. 160 mm



C432-02

C432-05

SPARE:

C433

EPOXY RESIN, to isolate the lateral surfaces of the concrete specimen. Can of 5 kg



WATER IMPERMEABILITY TESTER

DETERMINATION OF PENETRATION'S DEPTH OF WATER UNDER PRESSURE.

STANDARDS: EN 12390-8 / DIN 1048 / ISO 7031 / UNI 9533

This apparatus is used to determine the depth of penetration of the water into the concrete (impermeability) under known time and pressure. The unit accepts concrete cubic, cylindrical or prismatic specimens having "max. dimensions" of 200x200x200 mm.

The specimen is put into the test chamber, clamped with "suitable flanges with central screw" and round gaskets.

A known water pressure is applied on the specimen's surface for a known time, as requested by Standard, using a suitable air compressor (see accessory) having at least 5 bar pressure.

A manometer checks constantly the applied water pressure.

The apparatus is supplied "complete with graduated burettes" fixed on the front panel.

The water penetrated is measured by breaking the specimen, or by reading the water permeated through the graduated burette.

Two models available: three place and six place version.

The places can be used all-together at the same time, or one by one independently.



C435-01



C435

MODELS:

C435

Concrete water impermeability apparatus, three place, with water measurement burettes.

Dimensions: 1400x750x1700 mm

Weight: 280 kg approx.

C435SP

Concrete water impermeability apparatus, three place, same to mod. C435, but having three separate pressure lines

C435-01

Concrete water impermeability apparatus, six place, with water measurement burettes.

Dimensions: 1400x750x1850 mm

Weight: 430 kg approx.

C435-11

Dual pressure line

to upgrade the apparatus mod. C435-01

ACCESSORIES:

V206 AIR COMPRESSOR, 70 litres capacity, 230V 50Hz 1ph.

E138-11 TUBING and accessories to connect the impermeability apparatus to the air compressor.



MATEST manufactures a complete range of Mobile Laboratories as:

- Trailer-type mobile laboratory.
- Van-mounted mobile laboratory.
- Container mounted laboratory.

Both of small or large dimensions, by supplying also the mobile structure, benching, furniture, generators, air conditioning, electronic and plumbing installation etc; or by simply fixing the Testing Equipment on the mobile structure supplied by the customer.

section C



306



MATEST

Matest's technical staff is at complete disposal of the customer to study any specific requirement and to submit detailed proposals to satisfy the end-user's necessities.